



FOOD EQUIPMENT

SERVING THE FOOD INDUSTRY SINCE 1951

MEGA REFRIGERATED PREP TABLES

Item: 50049
Model: PT-CN-0711-HC

Item: 50050
Model: PT-CN-1194-H

Item: 50051
Model:



Omcan's Mega refrigerated prep tables provide ample storage space and 3/4" cutting boards / work area. Constructed of stainless steel and features self-closing doors.

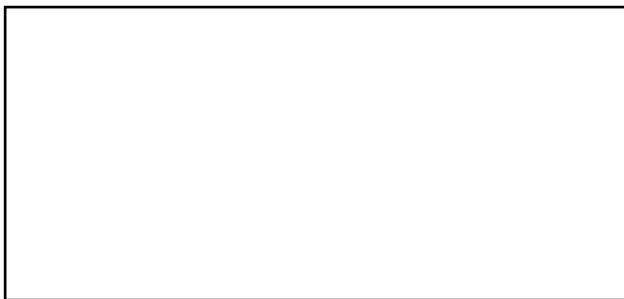

Authorized Dealer



WARRANTY

2 YEARS PARTS & LABOR
5 YEARS ONLY ON COMPRESSOR



FOOD EQUIPMENT

MEGA REFRIGERATED PREP TABLES



50049



50050/ 50051

Features:

- Stainless Steel exterior and interior
- Mechanical Temperature controller
- Removable door gasket
- Plastic coated shelves.
- 3/4" thick cutting board
- The units automatically defrost
- Polyurethane insulation
- Self-closing doors
- Casters

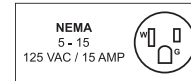

	27.5" 5.7 Cu. Ft.	47" 9.5 Cu. Ft.	60" 15 Cu. Ft.
ITEM NUMBER	50049	50050	50051
MODEL	PT-CN-0711-HC	PT-CN-1194-H	
DESCRIPTION	27.5" Mega Refrigerator	47" Mega Refrigerator	60-inch Mega Refrigerator
TEMPERATURE RANGE	0.5°C ~ 5°C / 33°F ~ 41°F	0.5°C ~ 5°C / 33°F ~ 41°F	0.5°C ~ 5°C / 33°F ~ 41°F
MAX AMBIENT TEMP RATING	90°F	90°F	
POWER	1/5 HP	1/4+ HP	1/4+ HP
ELECTRICAL	110V / 60Hz / 1Ph	110V / 60Hz / 1Ph	110V / 60Hz / 1Ph
AMPS	2.88	4.56	4.8
REFRIGERANT	R290	R290	R290
ISOLATION MATERIAL	cyclopentane	cyclopentane	
COOLING SYSTEM	Ventilated	Ventilated	
INSERT CAPACITY	nine 1/6 pans	Eighteen 1/6 pans	
NUMBER OF DOORS	1	2	2
NUMBER OF SHELVES	1	2	2
SHELF CAPACITY	77lbs./ 35kg	754 lbs./ 70kg	
EXTERIOR DIMENSIONS (WDH)	27.5" x 34" x 46" / 698 x 864 x 1166 mm	47" x 34" x 46" / 1194 x 864 x 1166 mm	60 1/5" x 34" x 45 9/10" / 1529 x 864 x 1166 mm
INTERIOR DIMENSIONS (WDH)	24" x 23.82" x 23.5" / 609.6 x 605 x 597 mm	42.83" x 23.82" x 23.5" / 1088 x 605 x 597 mm	
PACKAGING DIMENSIONS	31.8" x 39" x 49.13" / 808 x 991 x 486 mm	52.36" x 39" x 49.13" / 1330 x 991 x 486 mm	65 3/8" x 39" x 49 2/8" / 1660 x 990 x 1250 mm
NET VOLUME (CU. FT.)	5.7 cu. ft.	9.5 cu. ft.	15 cu. ft.
WEIGHT	198 lbs./ 90 kg.	298 lbs./ 135 kg.	330 lbs. / 150 kg.
PACKAGING WEIGHT	264.6 lbs/ 120 kg	408 lbs/ 185 kg	462 lbs. / 210 kg.

OMCAN INC.

Telephone: 1-800-465-0234
 Fax: (905) 607-0234
 Email: sales@omcan.com
 Website: www.omcan.com



Follow us to keep up to date with the latest news and offers



Technical drawing with dimensions:

28" Mega Refrigerator (Item 50049)

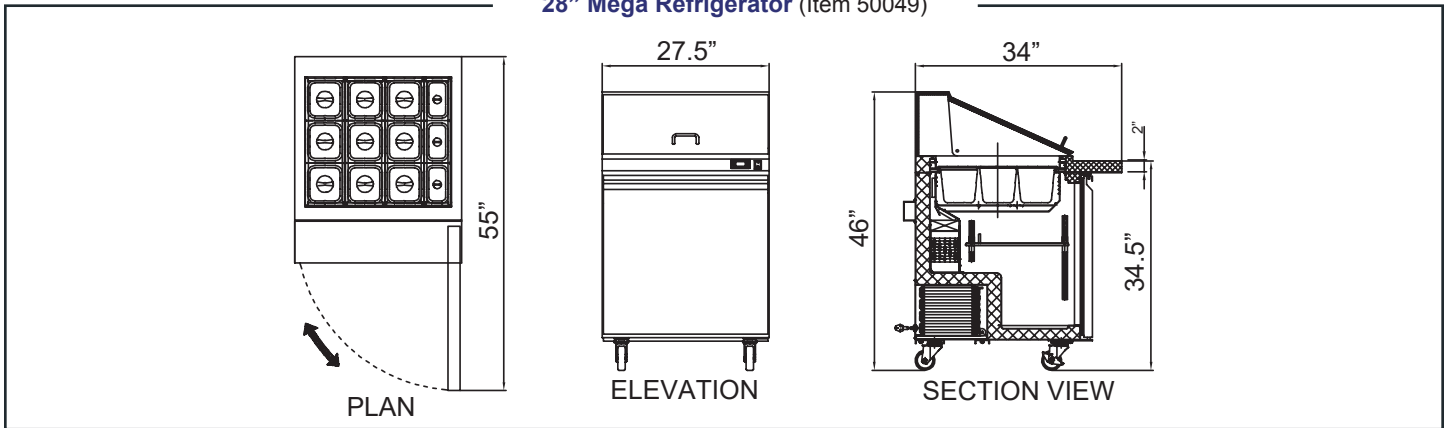

47" Mega Refrigerator (Item 50050)

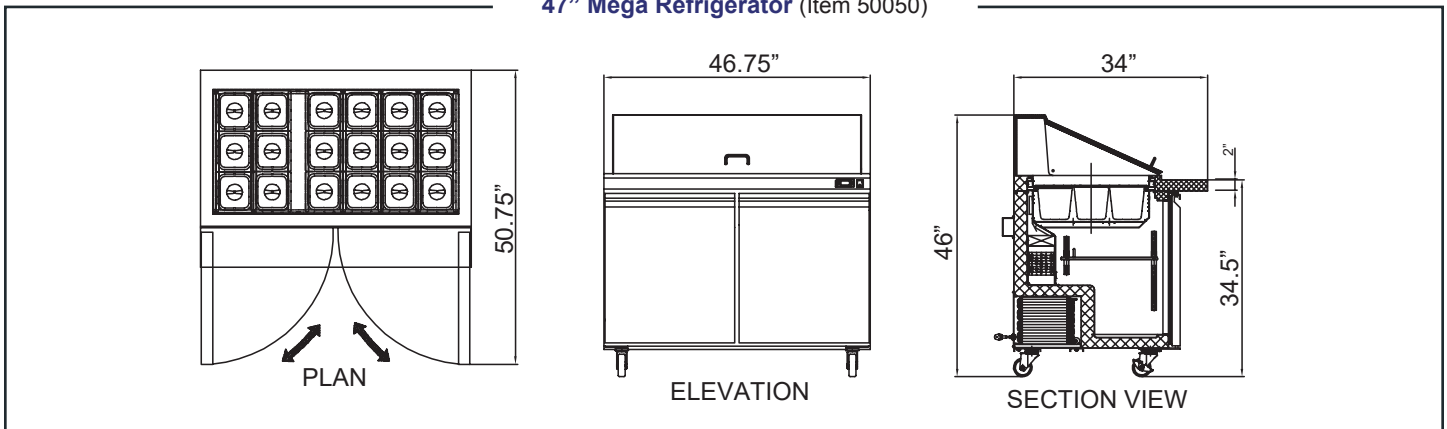

60" Mega Refrigerator (Item 24275)

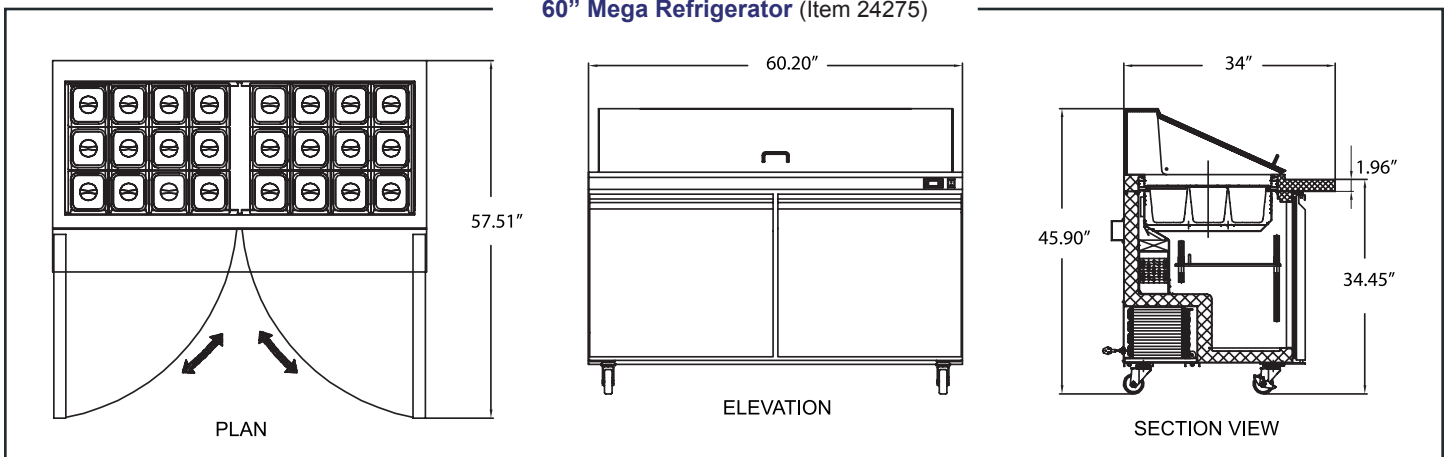

OMCAN INC.

Telephone: 1-800-465-0234
 Fax: (905) 607-0234
 Email: sales@omcan.com
 Website: www.omcan.com



Follow us to keep up to date with the latest news and offers

