

## "BHS16" WALL SHELVES

*Stainless Steel, 16" Wide w/1½" Rear Riser*

### FEATURES:

- Type 300 Stainless Steel With #4 Polish, Satin Finish
- Finished With A Safety Stallion Front Edge
- 1-1/2" Turned Up Backsplash
- 16" Width
- Shipped Knocked-Down, Easy-To-Assemble
- All Models Are NSF Certified

### SPECIFICATIONS:

- Stainless Steel Shelves Are MIG Welded
- Exposed Welds Are Polished To Match Adjacent Surface
- Shelf: Type 300 Stainless Steel With #4 Polish, Satin Finish
- Brackets: Type 300 Stainless Steel With #4 Polish, Satin Finish



### CERTIFICATIONS:



## "BHS16" STAINLESS STEEL WALL SHELVES

LENGTH	18GA	WT (LBS)	16GA	WT (LBS)	14GA	WT (LBS)
24"	BHS1624	10	BHS1624-16/304	14	BHS1624-14/304	17
30"	BHS1630	12	BHS1630-16/304	15	BHS1630-14/304	20
36"	BHS1636	14	BHS1636-16/304	17	BHS1636-14/304	23
48"	BHS1648	18	BHS1648-16/304	21	BHS1648-14/304	28
60"	BHS1660	24	BHS1660-16/304	26	BHS1660-14/304	33
72"	BHS1672 *	30	BHS1672-16/304 *	30	BHS1672-14/304 *	38
84"	BHS1684 *	34	BHS1684-16/304 *	36	BHS1684-14/304 *	45
96"	BHS1696 *	38	BHS1696-16/304 *	40	BHS1696-14/304 *	50
108"	BHS16108 *	43	BHS16108-16/304 *	44	BHS16108-14/304 *	55
120"	BHS16120 *	48	BHS16120-16/304 *	48	BHS16120-14/304 *	60
132"	BHS16132 **	53	BHS16132-16/304 **	52	BHS16132-14/304 **	65
144"	BHS16144 **	58	BHS16144-16/304 **	56	BHS16144-14/304 **	70

\* UNITS 72"-120" ARE FURNISHED WITH 3 SUPPORT BRACKETS, \*\* UNITS 132" & 144" HAVE 4 SUPPORT BRACKETS

ALL DIMENSIONS ARE TYPICAL. TOLERANCE +/- .500". JOHN BOOS & CO. RESERVES THE RIGHT TO CHANGE SPECIFICATIONS WITHOUT NOTICE.

# DETAILED SPECIFICATIONS

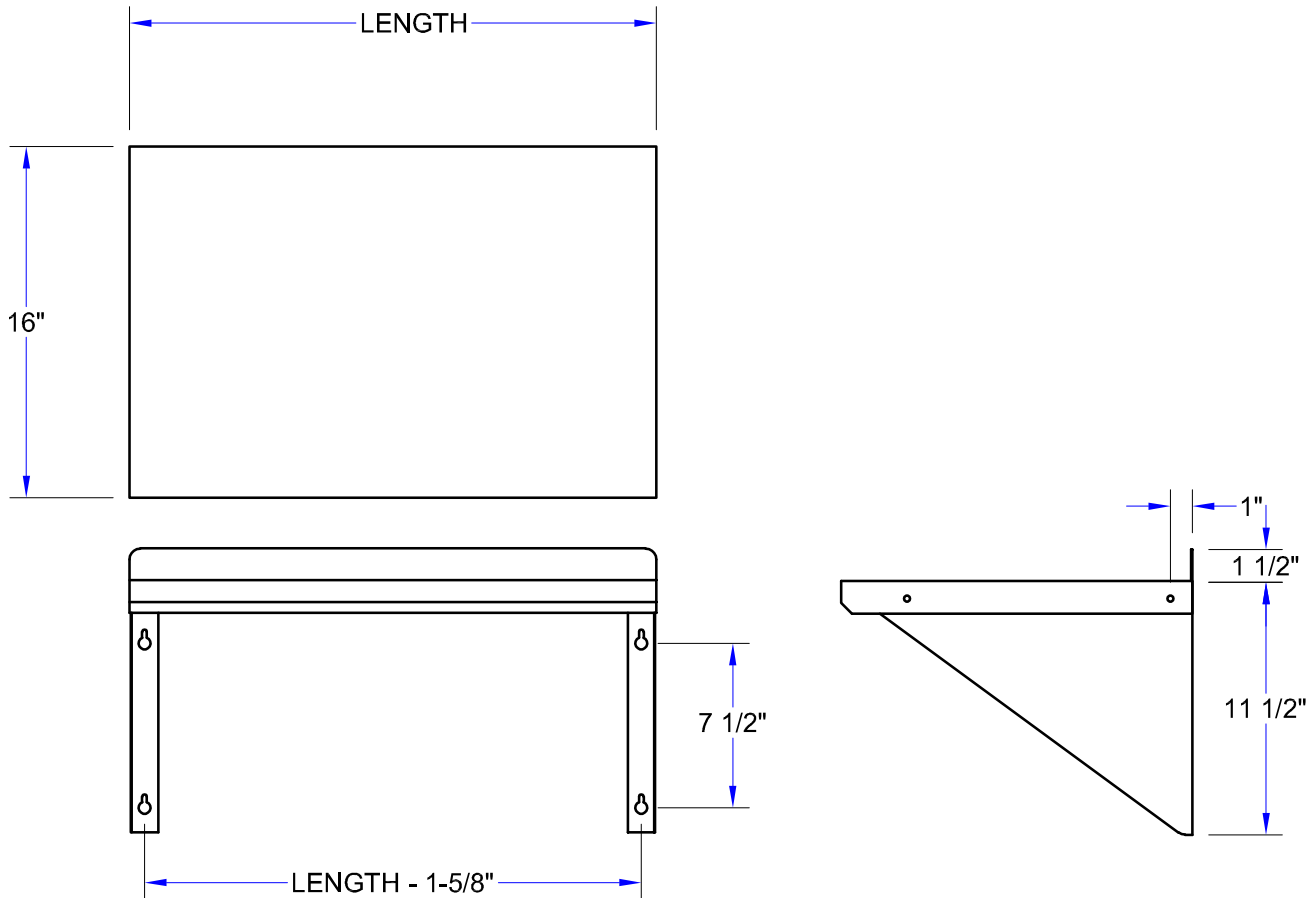

## "BHS16" STAINLESS STEEL WALL SHELVES

LENGTH	18GA	WT (LBS)	16GA	WT (LBS)	14GA	WT (LBS)
24"	BHS1624	10	BHS1624-16/304	14	BHS1624-14/304	17
30"	BHS1630	12	BHS1630-16/304	15	BHS1630-14/304	20
36"	BHS1636	14	BHS1636-16/304	17	BHS1636-14/304	23
48"	BHS1648	18	BHS1648-16/304	21	BHS1648-14/304	28
60"	BHS1660	24	BHS1660-16/304	26	BHS1660-14/304	33
72"	BHS1672 *	30	BHS1672-16/304 *	30	BHS1672-14/304 *	38
84"	BHS1684 *	34	BHS1684-16/304 *	36	BHS1684-14/304 *	45
96"	BHS1696 *	38	BHS1696-16/304 *	40	BHS1696-14/304 *	50
108"	BHS16108 *	43	BHS16108-16/304 *	44	BHS16108-14/304 *	55
120"	BHS16120 *	48	BHS16120-16/304 *	48	BHS16120-14/304 *	60
132"	BHS16132 **	53	BHS16132-16/304 **	52	BHS16132-14/304 **	65
144"	BHS16144 **	58	BHS16144-16/304 **	56	BHS16144-14/304 **	70

\* UNITS 72"-120" ARE FURNISHED WITH 3 SUPPORT BRACKETS, \*\* UNITS 132" & 144" HAVE 4 SUPPORT BRACKETS

ALL DIMENSIONS ARE TYPICAL. TOLERANCE +/- .500". JOHN BOOS & CO. RESERVES THE RIGHT TO CHANGE SPECIFICATIONS WITHOUT NOTICE.