

*Blueain by*  
**BLUENIX**

**MODEL BKGF49-HC**  
**GLASS DOOR**  
**MERCHANDISER**  
**FREEZER**

Sleek and durable cooling solution for your food and beverages.



**Stainless steel cabinet construction**

Stainless steel interior and exterior (galvanized steel back & bottom).



**Temperature range between -10°F ~ 5°F**

Air guard on rear wall ensures proper air circulation and cooling.



**Hydrocarbon refrigerants (R-290)**

Increases energy HFC refrigerants. It is safer for the environment and does not cause ozone depletion.



**Visual and audible door open alarm**

Alarm sounds when doors are not completely closed to protect against food spoilage

## Cabinet construction

- Black or white painted steel exterior and white painted steel interior
- High density foamed in place polyurethane insulation – Environmentally safe
- Sturdy, epoxy coated wire shelves with adjustable shelving height
- 4 shelves per compartment.
- Four 4" Diameter swivel casters with front brakes standard.

## Refrigeration

- Front sliding refrigeration unit allows the unit to be serviced without being moved.
- Self-contained system, bottom mounted compressor provides quick and easy maintenance.
- Epoxy coated evaporator reduces potential corrosion
- Fabric condensation

**Exterior Dimensions**  
(inches/mm)

L	D	H
54 3/8" 1382 mm	31 3/8" 805 mm	81 3/4" 2065 mm

**Weight**  
(lbs/kg)

Net Weight	Ship Weight
550 lbs 249 kg	601 lbs 272 kg



Conforms to NSF/ANSI 7(ETL)



Front view

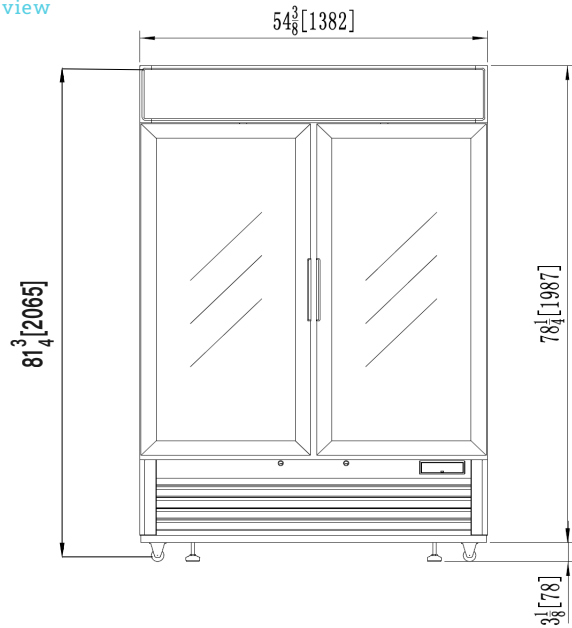

Side view

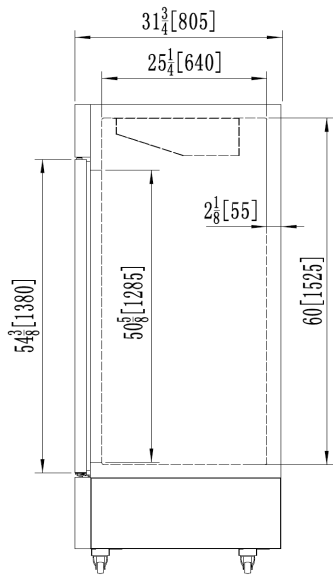

Top view

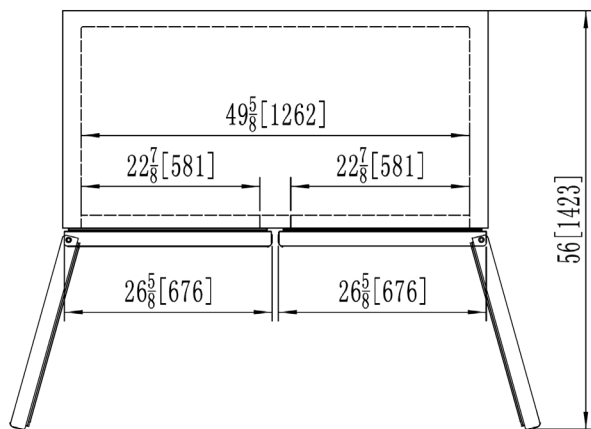

## Doors

- Self-closing doors (doors close at 90° or less)
- Automatic hold open door feature at 110°.
- Durable door gasket with easy replacement.
- Heavy duty recess door handles
- Door designed to open easily.
- Doors built with pressure and with pressure relievers to eliminate vacuum pressure.
- Standard door locks.
- Double pane glass

## Design & Features

- Digital temperature control & monitor system
- Keep food products safe by maintaining constant temperatures
- Digital display allows for easy monitoring.
- Programs interpret the condition of refrigeration
- Controls include automatic evaporator fan motor delays

## Optional Features & Accessories

- 2.5" diameter casters available
- 6" adjustable legs available
- Additional shelves are available.

Doors	2
Capacity Cu.Ft.	49
Shelves	8
Refrigerant	R-290
Temperature Range	-10°F ~ 5°F
Easy Maintenance	Sliding Condensing Unit
Connection	9.8 ft long (3m) flexible three wire cord with modeled plug
Lighting	LED Interior lighting
HP	3/4 HP
Voltage	115V/60Hz
Amps	3.2
NEMA Config.	NEMA 5-15



- This product may expose you to chemicals including Diisononyl Phthalate(DINP), which is known to the State of California to cause cancer. For more information go to [www.P65Warnings.ca.gov](http://www.P65Warnings.ca.gov).  
- Ce produit peut vous exposer à des agents chimiques incluant le Diisononyl Phthalate(DINP), reconnu par l'Etat de Californie comme causant le cancer, Pour de plus amples renseignements, consulter le site [www.P65Warnings.ca.gov](http://www.P65Warnings.ca.gov).

**Blueair by**  
**BLUENIX**

Blue Air has right to change specifications without further notice.



[blueairfse.com](http://blueairfse.com)



[orders@blueairfse.com](mailto:orders@blueairfse.com)



1-886-677-8500



223 W. Rosecrans Ave., CA 90248  
T: 310-808-0102

9 W. Shelton Terrace #A, Hillside, NJ 07205  
T: 908-688-0970