

Special Features:

- ✓ Type: Food Cooker / Warmer
- ✓ Configuration: Countertop
- ✓ Power Type: Electric
- ✓ 1 Full Sized 12" x 20" Well
- ✓ Maximum Pan Depth of 4"
- ✓ Stainless Steel Construction
- ✓ Control Type: Manual, Thermostatic
- ✓ Heating Method: Hot Water Bath
- ✓ Temperature Range: 120°F - 212°F
- ✓ Plug type: NEMA 5-15P
- ✓ This Model is Very Easy to Clean
- ✓ Holds Food Product at a Servable Temperature Complying With Health Code Regulations
- ✓ Certifications: NSF & UL Listed

Product Description:

The Empura E-FWC1500 is a full size countertop food cooker / warmer with a sturdy stainless steel construction, 4" max pan depth capacity & manual thermostatic temperature controls. This countertop food cooker / warmer features 1 full size 12" x 20" well that functions as a hot water bath with a temperature range of 120°F - 212°F that can cook and hold product at a servable temperature. This model is easy to clean and comes with a NEMA 5-15P plug.

Intended For Commercial Use Only. Empura assumes no liability for component failure, factory defects or any other damages for units installed in non-commercial foodservice or residential applications.

About Empura Food Cooker / Warmers:

Empura countertop food cooker / warmers are the perfect choice for any restaurant owner who is looking to expand their heated holding capacity or add the ability to cook and serve hot soups and other dishes on demand. Sturdy & durable stainless steel construction & steady temperatures make these countertop cooker / warmers the ideal option for restaurateurs. You can trust Empura countertop equipment to keep your food fresh & ready to serve!



TECHNICAL SPECS

Dimensions & Construction

Overall Width	14-1/2"
Overall Depth	22-1/2"
Overall Height	9"
Well Quantity	1
Well Size	Full
Well Width	12"
Well Depth	20"
Construction Material	Stainless Steel

Heating & Electrical

Style	Cooker / Warmer
Power Type	Electric
Control Type	Thermostatic
Temperature Range	120°F - 212°F
Plug Type	NEMA 5-15P
Voltage	120
Wattage	1500

UNIT VIEW

Front Angled View

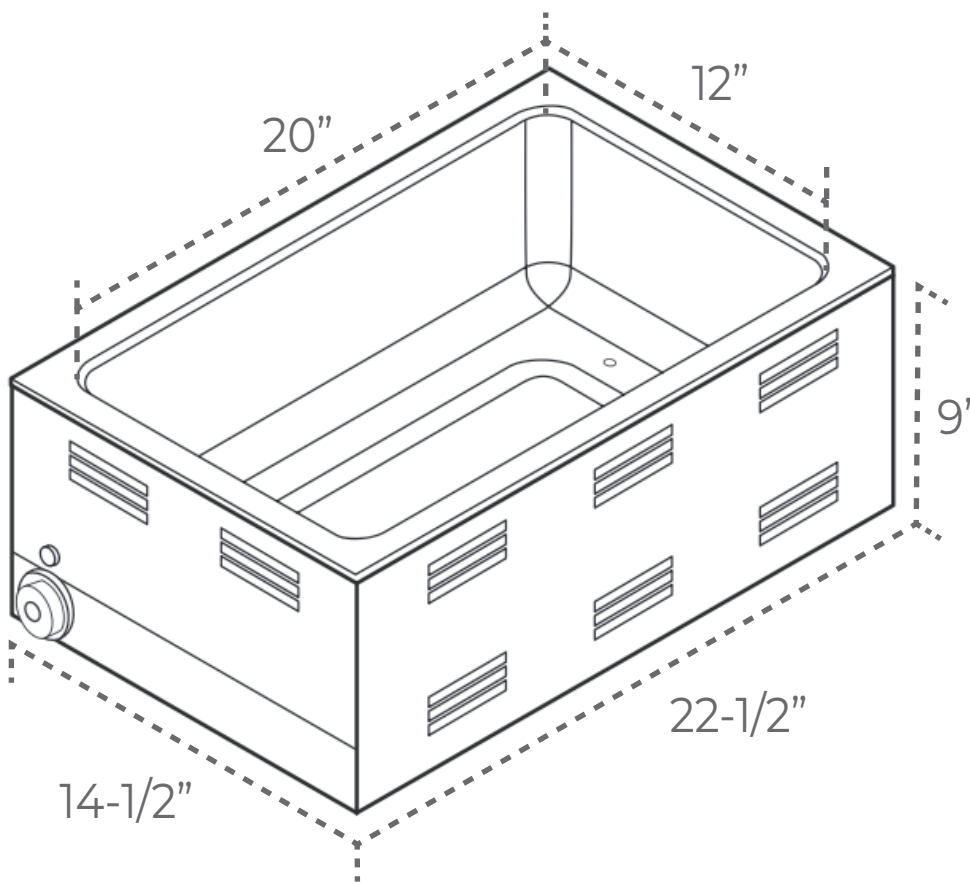

Attention CA Residents: This product can expose you to chemicals including lead, which are known to the State of California to cause cancer, birth defects, or other reproductive harm. For more information, go to www.p65warnings.ca.gov.



NEMA 5-15P Plug:
This unit comes with a NEMA 5-15P plug