



U-Star's Glass Door Reach-in Freezers are constructed of heavy duty stainless steel both inside and out, making them strong and durable enough to survive any kitchen environment. The cooling units are bottom mounted and slide out for easy maintenance and cleaning. All models come with 6" casters and plastic coated wire shelving that is easily removable to adjust the shelf height. The front digital controllers and LED readout makes it easy to adjust the interior temperature. These models are ETL Listed and ETL Sanitation. They are backed with a 1 year warranty on parts and labor a 5 year warranty on the compressor.

Product Features

- Electronic control system makes it easy to adjust temperature set point and defrost frequency. Preinstalled heavy-duty casters with brakes.
- Removable installation board makes it easy to access condenser coil for cleaning and service.
- These units use environmentally friendly R290 refrigerant
- Stainless steel interior and exterior, aluminum back.
- Refrigeration system keeps food at safe temperatures between -7 °F and 0 °F
- Self-Closing glass doors with locks and keys.
- Shelves: Adjustable heavy-duty PVC coated shelves.



This item meets the sanitation standards imposed by the ETL, a division of the Intertek Group.



This item meets the electrical product safety standards imposed by the ETL, a division of the Intertek Group, for use in the United States and Canada.

Plan Views

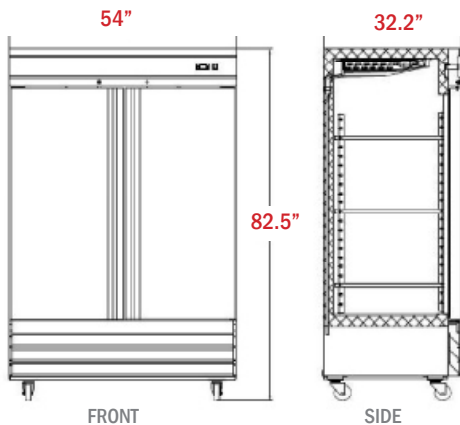
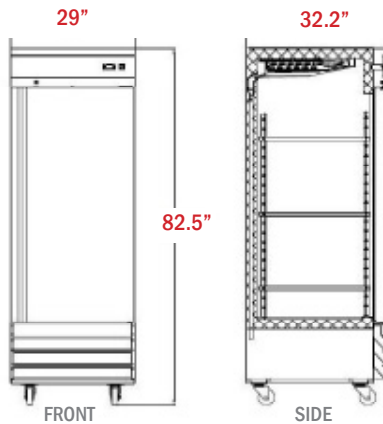

Specifications

Model Number	USFZ-1D-G	USFZ-2D-G
Doors	1	2
Shelves	3	6
Net Volume (Cu. Ft.)	23 Cu. Ft	48 Cu. Ft
Overall Dimensions (in)	29"W x 32.2"D x 82.5"H	54"W x 32.2"D x 82.5"H
Interior Dimensions (in)	24"W x 27"D x 60"H	49"W x 27"D x 60"H
Horsepower	1/5	1/4
Refrigerant	R290	R290
Voltage/Hertz/Phase	115/60/1	115/60/1
Amps	2.6	3.8
Net Weight (lbs)	282 lbs	448 lbs
Gross Weight (lbs)	322 lbs	536 lbs
Shipping Dimensions (in)	31.5"L x 35"W x 85"H	57"L x 35"W x 85"H

Plan Views

USFZ-1D-G

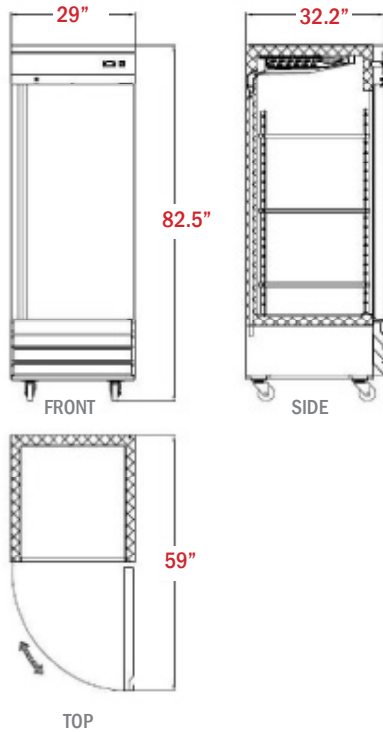

USFZ-2D-G

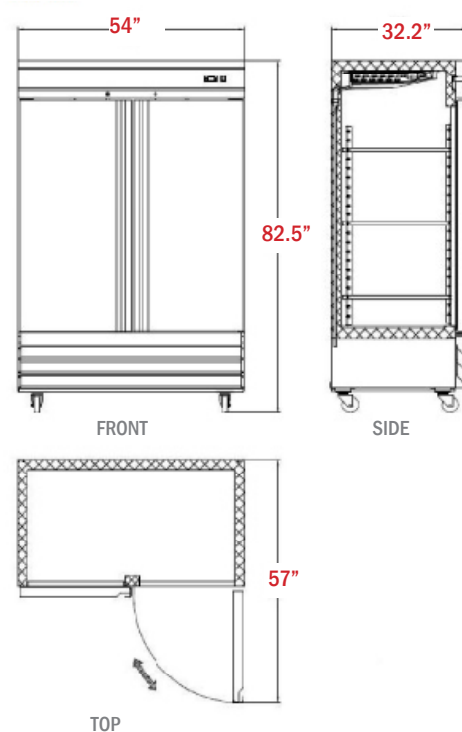

Features

Cooling System

- Refrigeration units use environmentally friendly R290 refrigerant
- Maintain a temperature range of -7°F-0°F
- Bottom mounted cooling unit slides out for easy cleaning and maintenance and allows for storage area on top of the unit
- Rugged built axial evaporator fans run efficiently with low velocity and high volume air flow

Electrical Control

- Electric LED temperature controller provides a digital display of cabinet temperatures and allows for easy temperature adjustments when necessary
- Temperature controller initiates automatic defrost schedule for worry free use
- 7 foot power cord with NEMA 5-15 plug



Cabinet Construction

- Exterior is constructed of 430 stainless steel
- Interior is constructed of 304 stainless steel
- The cabinet is insulated throughout with a foamed-in-place high density cell polyurethane insulation

Door(s)

- Positive self-closing doors with microswitch that shuts the evaporator fans off when the door is open
- Recessed handles are built into the door for easy opening and closing
- Locking door keep items inside secure after hours

Shelving

- Adjustable plastic coated steel shelves that have a load capacity of up to 120 lbs per shelf
- Specially designed stainless steel racking system allows for easy shelf height adjustment and gives the user the ability to slide out the shelf to better reach the food inside

Model Features

- Incandescent interior lighting activated by door switch
- 6" casters come standard on all stainless steel models. Two locking wheels and 2 non-locking wheels.