

"ST6R1.5-GSK" STAINLESS STEEL TOP WORK TABLES

16GA Top w/1.5" Riser & Galvanized Legs & Adjustable Undershelf

FEATURES:

- 16GA Stainless Steel Top
- Type 300 Stainless Steel With #4 Polish, Satin Finish
- Top Is Sound Deadened
- Reinforced With 1"x2" Channel Running Length Of Table
- 1-1/2" Stallion Edge On Front And 1-1/2" Backsplash On Rear With Side Edges 90 Degree Bend Down For Table Line-Up
- Galvanized Base With Adjustable Undershelf
- Adjustable Bullet Feet
- Shipped Knocked-Down, Easy-To-Assemble

SPECIFICATIONS:

- Top: Stainless Steel Tops Are TIG Welded, Exposed Welds Are Polished To Match Adjacent Surface
- Top: 16GA, Type 300 Stainless Steel With #4 Polish, Satin Finish
- Shelf: 18GA Galvanized Steel, (36" Wide Tables, 16GA Lower Shelf)
- Legs: 1-5/8" Round O.D. , 16GA Tubular Galvanized Steel
- Gussets: Galvanized Steel
- Feet: 1" Adjustable Stainless Steel Bullet Feet



ST6R1.5-3048GSK

CERTIFICATIONS:



ACCESSORIES

DESCRIPTION

- Drawer
- Drawer Lock
- Casters
- Overshelves
- Sinks
- Pot Rack

"ST6R1.5-GSK" STAINLESS STEEL TOP WORK TABLES

LENGTH	24" WIDE	WT	WT CAP	30" WIDE	WT	WT CAP	36" WIDE	WT	WT CAP
24"	ST6R1.5-2424GSK	42	900	ST6R1.5-3024GSK	47	900	ST6R1.5-3624GSK	56	900
30"	ST6R1.5-2430GSK	47	900	ST6R1.5-3030GSK	53	900	ST6R1.5-3630GSK	66	900
36"	ST6R1.5-2436GSK	53	900	ST6R1.5-3036GSK	60	900	ST6R1.5-3636GSK	73	900
48"	ST6R1.5-2448GSK	65	900	ST6R1.5-3048GSK	74	900	ST6R1.5-3648GSK	90	900
60"	ST6R1.5-2460GSK	76	610	ST6R1.5-3060GSK	88	610	ST6R1.5-3660GSK	107	610
72"	ST6R1.5-2472GSK	88	400	ST6R1.5-3072GSK	101	400	ST6R1.5-3672GSK	126	400
84"	ST6R1.5-2484GSK	107	1350	ST6R1.5-3084GSK	123	1350	ST6R1.5-3684GSK	152	1350
96"	ST6R1.5-2496GSK	118	1350	ST6R1.5-3096GSK	136	1350	ST6R1.5-3696GSK	170	1350
108"	ST6R1.5-24108GSK	130	1350	ST6R1.5-30108GSK	149	1350	ST6R1.5-36108GSK	187	1350
120"	ST6R1.5-24120GSK	140	1130	ST6R1.5-30120GSK	163	1130	ST6R1.5-36120GSK	204	1130
132"	ST6R1.5-24132GSK	152	900	ST6R1.5-30132GSK	177	900	ST6R1.5-36132GSK	221	900
144"	ST6R1.5-24144GSK	164	680	ST6R1.5-30144GSK	191	680	ST6R1.5-36144GSK	238	680

OVERALL WEIGHT (WT) AND MAX WEIGHT CAPACITY (WT CAP) ARE IN POUNDS (LBS). MAX WEIGHT CAPACITY EVENLY DISTRIBUTED. ALL DIMENSIONS ARE TYPICAL. TOLERANCE +/- .500". JOHN BOOS & CO. RESERVES THE RIGHT TO CHANGE SPECIFICATIONS WITHOUT NOTICE.

DETAILED SPECIFICATIONS

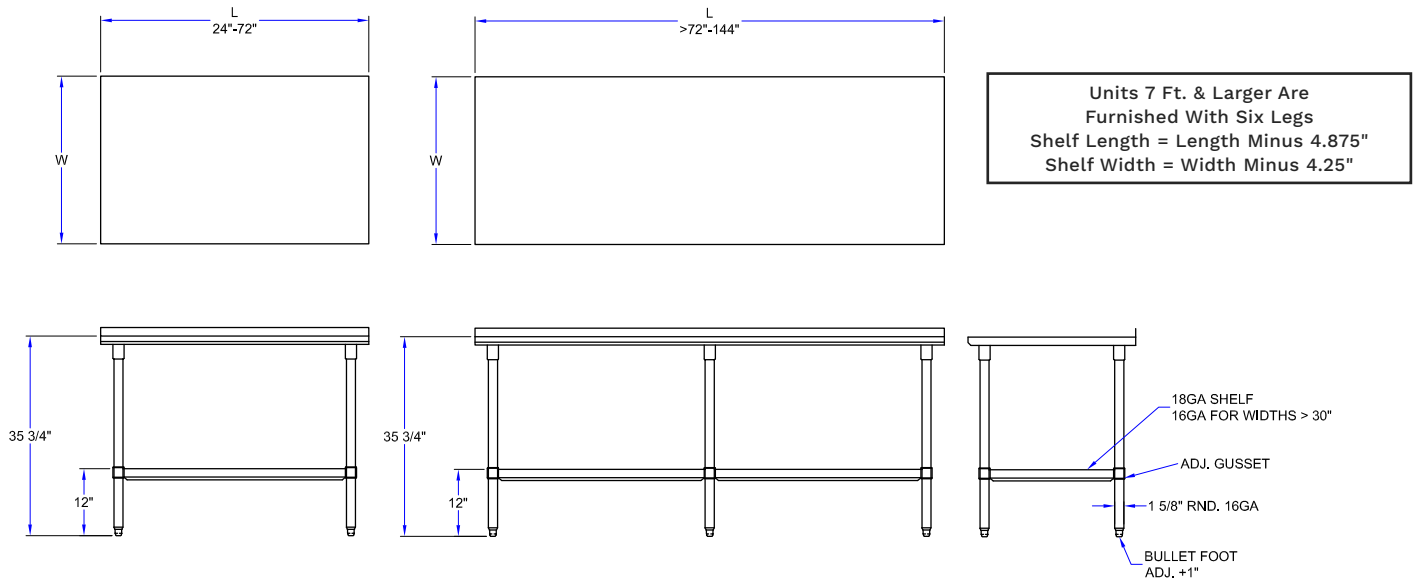

MODEL # STRUCTURE

1.5 = Ht. Of Riser w/Turndown
R = Top w/Riser
6 = 16GA Work Surface
ST = Stainless Steel Top



"ST6R1.5-GSK" STAINLESS STEEL TOP WORK TABLES

LENGTH	24" WIDE	WT	WT CAP	30" WIDE	WT	WT CAP	36" WIDE	WT	WT CAP
24"	ST6R1.5-2424GSK	42	900	ST6R1.5-3024GSK	47	900	ST6R1.5-3624GSK	56	900
30"	ST6R1.5-2430GSK	47	900	ST6R1.5-3030GSK	53	900	ST6R1.5-3630GSK	66	900
36"	ST6R1.5-2436GSK	53	900	ST6R1.5-3036GSK	60	900	ST6R1.5-3636GSK	73	900
48"	ST6R1.5-2448GSK	65	900	ST6R1.5-3048GSK	74	900	ST6R1.5-3648GSK	90	900
60"	ST6R1.5-2460GSK	76	610	ST6R1.5-3060GSK	88	610	ST6R1.5-3660GSK	107	610
72"	ST6R1.5-2472GSK	88	400	ST6R1.5-3072GSK	101	400	ST6R1.5-3672GSK	126	400
84"	ST6R1.5-2484GSK	107	1350	ST6R1.5-3084GSK	123	1350	ST6R1.5-3684GSK	152	1350
96"	ST6R1.5-2496GSK	118	1350	ST6R1.5-3096GSK	136	1350	ST6R1.5-3696GSK	170	1350
108"	ST6R1.5-24108GSK	130	1350	ST6R1.5-30108GSK	149	1350	ST6R1.5-36108GSK	187	1350
120"	ST6R1.5-24120GSK	140	1130	ST6R1.5-30120GSK	163	1130	ST6R1.5-36120GSK	204	1130
132"	ST6R1.5-24132GSK	152	900	ST6R1.5-30132GSK	177	900	ST6R1.5-36132GSK	221	900
144"	ST6R1.5-24144GSK	164	680	ST6R1.5-30144GSK	191	680	ST6R1.5-36144GSK	238	680

OVERALL WEIGHT (WT) AND MAX WEIGHT CAPACITY (WT CAP) ARE IN POUNDS (LBS). MAX WEIGHT CAPACITY EVENLY DISTRIBUTED.
ALL DIMENSIONS ARE TYPICAL. TOLERANCE +/- .500". JOHN BOOS & CO. RESERVES THE RIGHT TO CHANGE SPECIFICATIONS WITHOUT NOTICE.