

4572NP

Front-Breathing Self-Contained Flat Top Freezer Bases

Models

- 4572NP Three Section with Doors
- ST4572NP Three Section with Doors with Backsplash



4572NP

Standard Features

- All 4500 Series units are 100% front breathing, which allows the unit to be pushed against a wall or built into a cabinet, or an existing lineup.
- Durable, rugged stainless-steel sides, top and front
- Features Delfield's exclusive ABS interior (on sides). ABS is extremely durable – it won't dent, chip or corrode and is backed by a limited lifetime warranty.
- Bent in full length handle on doors
- Standard on 5" casters for easy cleaning and installation
- One wire shelf standard, installed per door section.
- ACT solid state electronic control
- Environmentally friendly R290 refrigerant
- High density foamed in place, environmentally friendly, Kyoto Protocol Compliant, Non ODP (Ozone Depletion Potential), Non GWP (Global Warming Potential) polyurethane keeps energy costs low.
- 10' cord and plug supplied
- Three-year parts and labor warranty and a seven-year compressor parts warranty

Options & Accessories

- 18" wide single tier over shelf
- Stainless steel finish on back
- Cutting Boards
- Plastic laminate on front
- Additional wire shelves
- 3" casters, 4" ride height available
- Door lock
- Exterior thermometer (some models excluded)

Specifications

Exterior top is one-piece, 22-gauge stainless steel with integral 2.12" (5.4cm) square nosing on the front. ST models have standard backsplash, full width and 4" (10cm) tall.

Exterior back and bottom are two-piece 24-gauge galvanized steel. Exterior ends are stainless steel. Interior sides are thermoformed ABS plastic with integral shelf supports. Base is fully insulated with high density foamed in place, environmentally friendly, Kyoto Protocol Compliant, Non ODP (Ozone Depletion Potential), Non GWP (Global Warming Potential) polyurethane.

Refrigeration system uses environmentally friendly R290 refrigerant. Condenser coil and hot gas condensate evaporator mounted on rear of cabinet. Evaporator coil is located on the interior rear wall of cabinet. Refrigerant flow is controlled by a capillary tube. Cabinet maintains an interior temperature of 0°F to 5°F (-18°C to -21°C).

ACT control: ACT electronic, solid-state control, mounted on the exterior rear of the cabinet, allows unit to maintain precise temperatures in heavy duty conditions.

Electrical connection is 115 volt, 60 Hertz, single phase. Unit has a 10' (3m) long electrical cord and NEMA 5-15 plug.

Casters: Equipment is mounted on 5" (13cm) diameter plate casters with front two locking brakes. Equipment clearance above the floor is 2.5" (6cm).

Doors have a 22-gauge stainless steel exterior, with thermoformed ABS plastic interior liner. Cabinet has one adjustable wire shelf.

Drawers are not available on 72" models.



4572NP Flat Top Freezer Bases

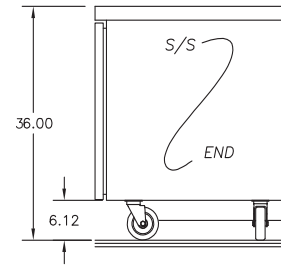
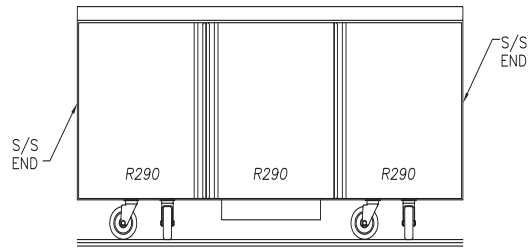
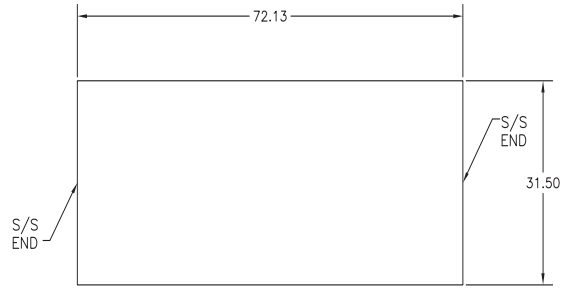

Model: 4572NP

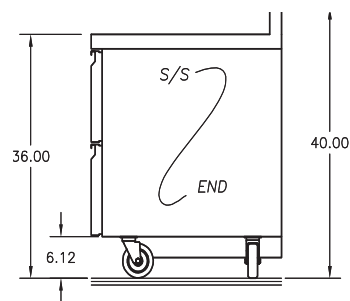
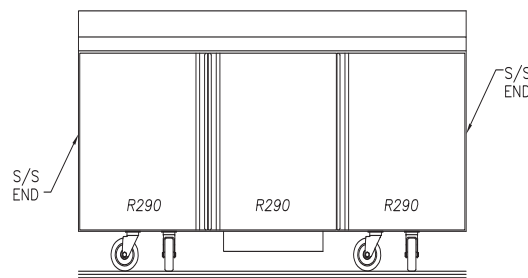
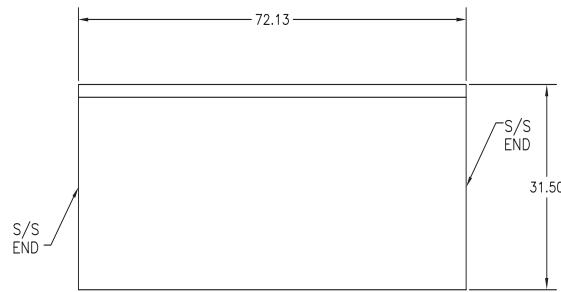

Model: ST4572NP

Specifications

Model	# of Shelves	Shelf Area	Storage Volume	h.p.	V/Hz/Ph	Amps	Energy (kWh/day)	nema plug	Ship Weight
4572NP	3	8.22ft ²	22.37ft ³	0.45	115/60/1	5.7	4.22	5-15P	461lbs/209kg
ST4572NP	3	8.22ft ²	22.37ft ³	0.45	115/60/1	5.7	4.22	5-15P	461lbs/209kg

Welbilt reserves the right to make changes to the design or specifications without prior notice.