



VIPER™ HIGH OUTPUT FROZEN 3 FLAVOR FROZEN DISPENSER



FEATURES

Our 40+ years of expertise makes Viper the most intelligent, innovative and reliable frozen beverage dispenser in the world.

Optimized refrigeration design – Boost sales and profits with industry leading capacity to meet peak demand while maintaining drink quality

C3 Technology – Provides unmatched drink profile consistency, builds repeat sales and minimizes syrup usage

Intelligent Defrost™ – Adaptive defrost allows you to make every sale with equipment that is always ready-to-serve

Flexible product delivery system – Sell the drinks consumers want today and in the future with incomparable individual barrel flexibility (FCB/FUB) and profile settings

Robust design and solid-state controls – Common field issues are resolved

Energy consumption – Best-in-class energy use

Programmable sleep mode – Conserves energy in off hours

LED lighting – Eliminates lost sales due to lights out and costly bulb replacements

Technician designed – Reduced maintenance and service times

ADA Compliant – Newly redesigned handles comply with ADA regulations

MODELS

PART NUMBER	DESCRIPTION
621360142	Viper 3 flavor unit, 230/60Hz, air cooled, SPH valves, stainless steel panels, tall merchandiser
621360042	Viper 3 flavor unit, 230/60Hz, air cooled, Motorman valves, stainless steel panels, tall merchandiser
621360141	Viper 3 flavor unit, 230/60Hz, air cooled, SPH valves, stainless steel panels, short merchandiser
621360041	Viper 3 flavor unit, 230/60Hz, air cooled, Motorman valves, stainless steel panels, short merchandiser
621350142	Viper 3 flavor unit, 230/50Hz, air cooled, SPH valves, stainless steel panels, tall merchandiser
621350042	Viper 3 flavor unit, 230/50Hz, air cooled, Motorman valves, stainless steel panels, tall merchandiser
621350141	Viper 3 flavor unit, 230/50Hz, air cooled, SPH valves, stainless steel panels, short merchandiser
621350041	Viper 3 flavor unit, 230/50Hz, air cooled, Motorman valves, stainless steel panels, short merchandiser

SPH stands for Stainless Pull Handle. For FUB applications, Motorman valves are recommended.

ACCESSORIES

PART NUMBER	DESCRIPTION
629087406	Leg kit, 4" legs adjustable to 5.25"
620053990	Viper 3 flavor cart, stainless steel
620046410	Viper 3 flavor generic graphic for tall merchandiser
620047173	Viper 3 flavor generic graphic for short merchandiser
620042868	Generic flavor card set (includes 18 flavors)
629097128	Viper ADA kit SPH Black no pin - interim solution

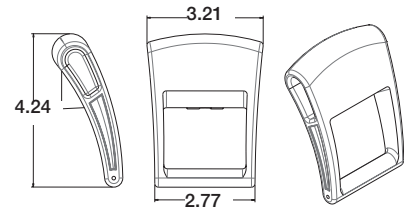

Viper ADA Handle

Refer to installation accessory guideline for complete list.

TECHNICAL SPECIFICATIONS

ELECTRICAL RATINGS. 230V +/- 15V 60Hz, 30a, single phase
 230V +/- 15V 50HZ, 30a, single phase
 (includes 8ft. power cord NEMA L6-30P molded plug connection)

PRESSURE REQUIREMENTS . . . CO2 = 75 psig
 Water = 25 min. psig dynamic

DRAW CAPACITY 75 oz/min. continuous, alternating barrels @ 75°F ambient

REFRIGERATION. 19,000 BTU, R404A

MINIMUM CLEARANCE REQUIRED. Top: 12"
 Each side: 2" or Back: 2"
 NOTE: Temperature above 100°F requires additional clearance

UNIT DIMENSIONS. 22.75"W x 32.5"D x 43.7"H (tall merchandiser)
 22.75"W x 32.5"D x 37"H (short merchandiser)

MERCHANDISER DIMENSIONS. . . 22.5"W x 18.75"H (tall merchandiser)
 22.5"W x 11.79"H (short merchandiser)

FLAVOR CARD DIMENSIONS. . . . 6.5"W x 4"H

SHIPPING WEIGHT 465 lbs; cart 175 lbs

AGENCY LISTINGS   

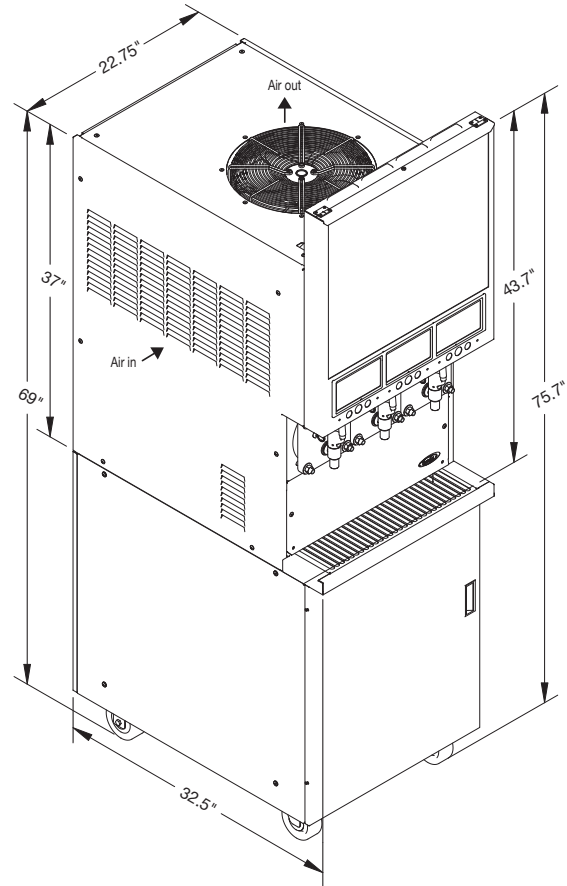

© 2014 CORNELIUS CG5086-0114

IN THE U.S.A.
 Ph: 800.238.3600
 Fax: 800.258.0255

OUTSIDE THE U.S.A.
 Ph: 763.488.8200
 Email: webmaster@cornelius.com

101 Broadway Street West
 Osseo, MN 55369
 www.cornelius.com

For more information or to place an order, contact your sales representative or authorized distributor.