

## "4CB4R10" BEVERAGE TABLES

*14GA Stainless Steel Top w/10" Rear Riser - Open Front*

**FEATURES:**

- 10" Backsplash Top With Turndown
- 1-1/2" Stallion Edge On Front And 90 Degree Bend Down Side Edge For Table Line-Up
- Non-Drip Marine Countertop Edge
- 18"x18"x12" Sink With 4" O/C Splash Mount Faucet Holes
- Includes Urn Trough And Louvered Grate With Drain And Rack Slides
- 1-Ph Duplex Outlet
- Top Is Sound Deadened Reinforced With 2"x3" Channel Running Entire Length Of Top
- Stainless Steel Leg With Adjustable Feet
- 36" Working Height
- Shipped Standard Welded Set-Up

**SPECIFICATIONS:**

- Top: Stainless Steel Cabinet Tops TIG Welded, Exposed Welds Are Polished To Match Adjacent Surface #4 Polished, Satin Finish
- Removable Stainless Steel Legs
- Hinged Door Is Constructed As A Double Panel Door
- Top: 14GA Type 300 Stainless Steel With #4 Polish, Satin Finish
- Body: 18GA Type 430 Stainless Steel
- Legs: Stainless Steel With Adjustable Feet



4CB4R10-3060-L

**CERTIFICATIONS:**



### "4CB4R10" MODULAR BASE WORK TABLES

| LENGTH | MODEL (SINK ON LH) | MODEL (SINK ON RH) | A   | B   | WT (LBS) |
|--------|--------------------|--------------------|-----|-----|----------|
| 48"    | 4CB4R10-3048-L     | 4CB4R10-3048-R     | 18" | 12" | 230      |
| 60"    | 4CB4R10-3060-L     | 4CB4R10-3060-R     | 24" | 20" | 250      |
| 72"    | 4CB4R10-3072-L     | 4CB4R10-3072-R     | 36" | 20" | 300      |
| 84"    | 4CB4R10-3084-L     | 4CB4R10-3084-R     | 36" | 20" | 350      |
| 96"    | 4CB4R10-3096-L     | 4CB4R10-3096-R     | 36" | 20" | 400      |
| 108"   | 4CB4R10-30108-L    | 4CB4R10-30108-R    | 36" | 20" | 450      |
| 120"   | 4CB4R10-30120-L    | 4CB4R10-30120-R    | 36" | 20" | 500      |
| 132"   | 4CB4R10-30132-L    | 4CB4R10-30132-R    | 36" | 20" | 525      |
| 144"   | 4CB4R10-30144-L    | 4CB4R10-30144-R    | 36" | 20" | 550      |

ALL DIMENSIONS ARE TYPICAL. TOLERANCE +/- .500". JOHN BOOS & CO. RESERVES THE RIGHT TO CHANGE SPECIFICATIONS WITHOUT NOTICE.

# DETAILED SPECIFICATIONS

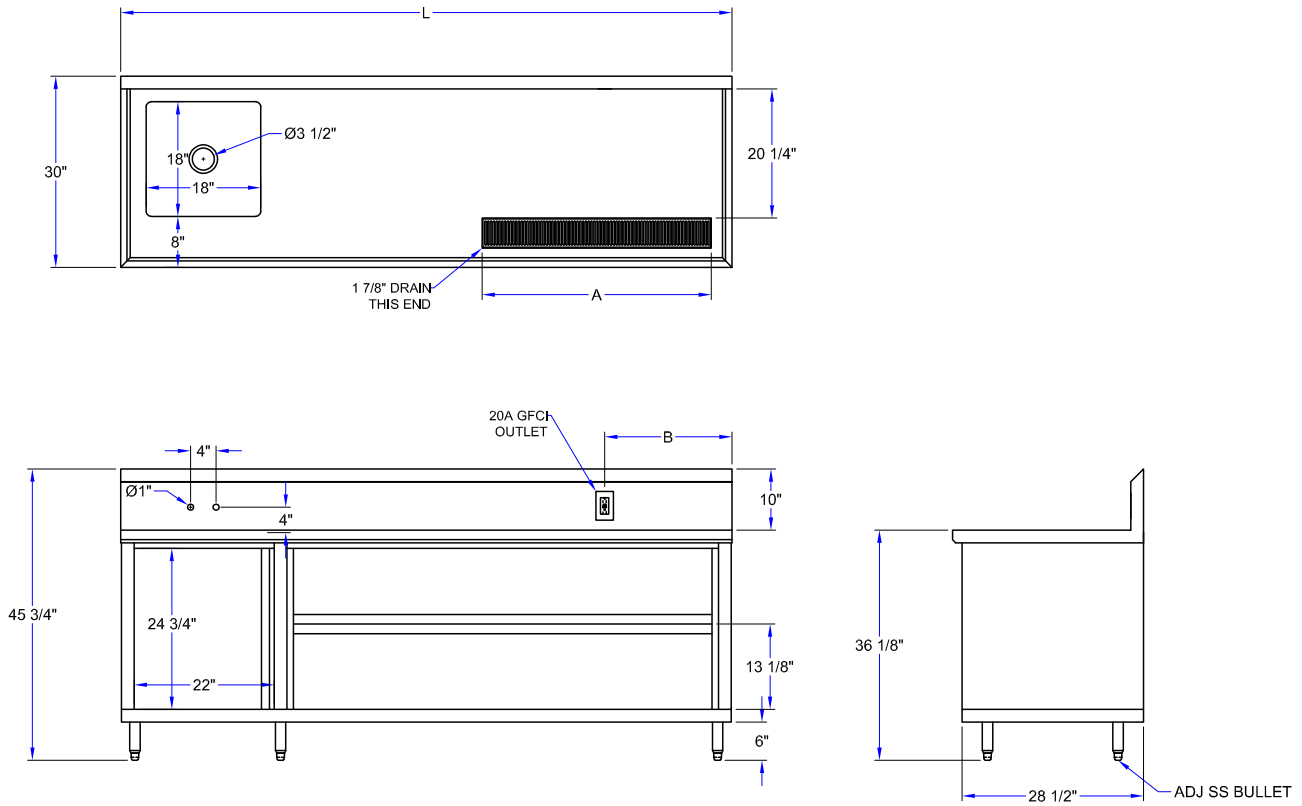

## "4CB4R10" MODULAR BASE WORK TABLES

| LENGTH | MODEL - SINK ON LH | MODEL - SINK ON RH | A   | B   | WT (LBS) |
|--------|--------------------|--------------------|-----|-----|----------|
| 48"    | 4CB4R10-3048-L     | 4CB4R10-3048-R     | 18" | 12" | 230      |
| 60"    | 4CB4R10-3060-L     | 4CB4R10-3060-R     | 24" | 20" | 250      |
| 72"    | 4CB4R10-3072-L     | 4CB4R10-3072-R     | 36" | 20" | 300      |
| 84"    | 4CB4R10-3084-L     | 4CB4R10-3084-R     | 36" | 20" | 350      |
| 96"    | 4CB4R10-3096-L     | 4CB4R10-3096-R     | 36" | 20" | 400      |
| 108"   | 4CB4R10-30108-L    | 4CB4R10-30108-R    | 36" | 20" | 450      |
| 120"   | 4CB4R10-30120-L    | 4CB4R10-30120-R    | 36" | 20" | 500      |
| 132"   | 4CB4R10-30132-L    | 4CB4R10-30132-R    | 36" | 20" | 525      |
| 144"   | 4CB4R10-30144-L    | 4CB4R10-30144-R    | 36" | 20" | 550      |

ALL DIMENSIONS ARE TYPICAL. TOLERANCE +/- .500". JOHN BOOS & CO. RESERVES THE RIGHT TO CHANGE SPECIFICATIONS WITHOUT NOTICE.