



BEVERAGE-AIR

Project: _____	AIA#
Item: _____	
Location: _____	SIS#
Approved: _____	

BB78HC BACK BAR REFRIGERATOR

BAR EQUIPMENT- BACK BAR REFRIGERATOR

MODEL:
BB78HC-1-B

BB78HC Solid Door
Hydrocarbon Series



7 Year Parts/Labor Warranty
7 Year Compressor Warranty

CABINET CONSTRUCTION

- Exterior features durable black painted steel
- Interior construction utilizes galvanized steel on walls and ceiling, heavy duty stainless steel floor
- Full electronic control
- 1 ½" Stainless steel top
- Self-closing doors with 120° stay-open feature
- Field reversible doors (hinge kit not included)
- Door locks
- Magnetic door gaskets provide positive door sealing
- LED lighting
- Packaged products only
- Six (6) epoxy coated wire shelves
- Compressor available on left or right, specify at time of unit order
- Balanced, forced air refrigeration system provides rapid chilling of product

OPTIONS & ACCESSORIES

- For stainless steel interior (refer to -F models)
- Galvanized sub-top
- Wine model (40°-60° models)
- Wire shelf divider
- Additional shelves
- Additional shelf clips
- 3" or 6" Casters
- 6" Black legs
- Remote option* (see note on back on page)

REFRIGERATION SYSTEM

- Uses environmentally friendly, energy efficient R290 refrigerant, and meets all regulatory requirements for CARB, SNAP, DOE & more
- Adaptive defrost
- Epoxy coated evaporator coil
- Maintains product temperature between 36°F and 38°F



Please verify qualifying units by visiting:
www.energystar.gov/cfs

3779 Champion Blvd., Winston-Salem, NC 27105
1-888-845-9800 Fax: 1-336-245-6453
Beverage-Air.com Sales@bevair.com



BEVERAGE-AIR

MODEL	BB78HC-1-B
EXTERNAL DIMENSIONAL DATA	
Width Overall (in)	79"
Depth Overall (in)	29 1/8"
Height Overall (in)	37 1/4"
Number of Doors	3
Depth with Door Open 90° (in)	49 1/4"
Door Openings (in)	19 7/8" x 30"
INTERNAL DIMENSIONAL DATA	
NET Capacity (cubic ft.)	33.59
Internal Width Useable (in)	66 1/4"
Internal Depth Overall (in)	23"
Internal Height Overall (in)	32 1/8"
Number of Shelves	6
Number of 1/2 Kegs	4
ELECTRICAL DATA	
Full Load Amperes	5.5
REFRIGERATION DATA	
Horsepower	1/3
Capacity (BTU/Hr)	2392
Heat Rejection (BTU/Hr)	3588
Charge (lbs/grams/ounces)	0.2535 / 115 / 4.06
SHIPPING DATA	
Gross Weight - Crated	448 lbs
Height - Crated	44"
Width - Crated	81"
Depth - Crated	31"

*NOTE: Remote units are field wired and come with 6" legs.
Refrigerant must be specified at time of order.

We reserve the right to change specifications and product design without notice. Such revisions do not entitle the buyer to corresponding changes, improvements, additions or replacements for previously purchased equipment. Dimensional tolerances +/- 1/4". Metric dimensions (MM).

Bar Equipment-Back Bar Refrigerator Model: BB78HC-1-B

Model Views

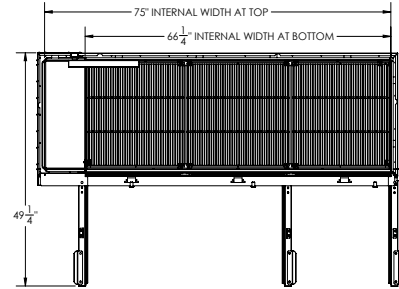

PLAN VIEW

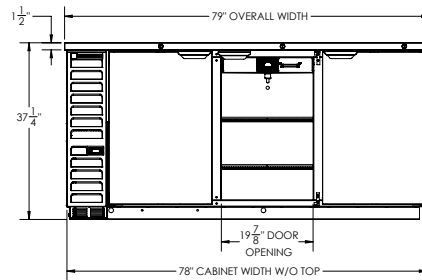

ELEVATION VIEW

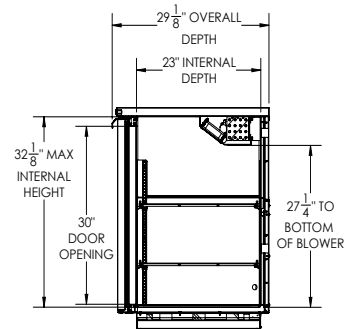

SIDE VIEW



ELECTRICAL CONNECTION

115/60/1
NEMA 5-15P

Unit pre-wired at factory
and include 8' long cord
and plug set.