

Project _____

Item Number _____

Quantity _____

SRM60+PM



60 Quart (qt.) Floor Model Pizza Mixer with Dough Hook Only

MADE IN THE USA

Model:

- SRM60+PM: 60 qt. FLOOR MODEL PIZZA MIXER WITH DOUGH HOOK ONLY



Floor Model Mixer

Features:

- 3 hp capacitor start motor
- Variable Speed Drive: 2 fixed speeds or any speed in-between
- Change speeds without having to stop the mixer
- Two-piece, stainless steel, dishwasher safe safety guard
- #12 Power Take-Off (PTO) hub
- Heavy-duty stainless steel bowl
- Interlock switches protect operator from injury if safety guard is open or bowl is lowered
- Hardened alloy gears in transmission
- Low voltage protection prevents accidental start up after power failure
- Durable NSF approved hybrid epoxy/polyester powder coat finish

Standard Accessories:

- 15 minute timer
- 60 qt. stainless steel bowl
- Dough hook
- Ingredient chute
- Power bowl lift

Optional Accessories:

- Splash ring
- Cover
- Sweet dough beater
- Wire whip
- 60 qt. pastry knife
- Four wing beater
- Bowl truck
- Batter beater

Optional Attachments:

- VS9 vegetable slicer with adjustable knife
- VS9H vegetable shredder with plate holder and 3/16" plate (additional plate size variations, grater plates, and julienne plate available)
- ALMFC12 meat and food grinder

Warranty:

- Two year, on-site parts and labor

Univex Corporation



WE RAISE THE BAR. WE SET THE STANDARD.

60 Quart Floor Model Pizza Mixer

SRM60+PM

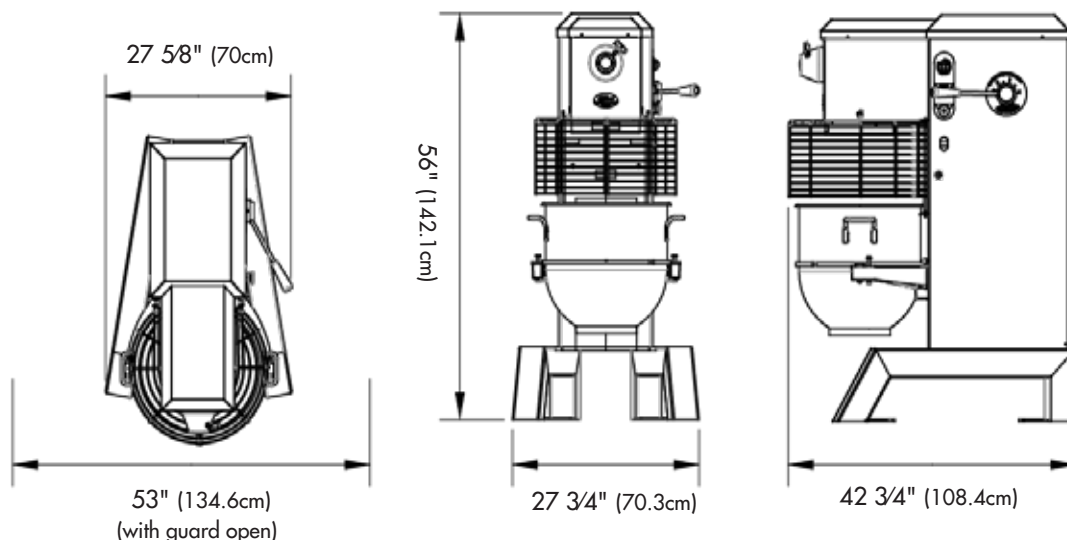

Shipping Information		
Net Weight	Shipping Weight	Overall Dimensions
750 lbs (340.2Kg)	1000 lbs (453.6Kg)	66" (167.6cm) H x 41" (104.1 cm) W x 51" (129.5cm) D
The weight and dimensions of the pallet are included in the weight and dimensions above.		

Electrical Information (60Hz)				
Attached 6 foot cord				
	Voltage	Phase	AMPS	NEMA
Standard	208-240	1	16.0-16.8	6-20P
Optional	208-240	3	8.0-8.5	L15-20
	460	3	4	L16-20

Mixer Speeds		
Speed	1	2
Beater Shaft (RPM)	90	166
PTO (RPM)	90	163

Bowl Capacity: 60 qts. (56.7 liters)

Motor: 3 hp capacitor start

Controls: Momentary contact stop & start buttons and contactor magnetic starter with overload protection

Bowl Lift: Power bowl lift standard OR ergonomic hand operated crank, self locking in top & bottom position

Lubrication: Oil bath

Transmission: Oil bath featuring hardened alloy gearing and torque sensing variable speed pulleys



Univex Corporation
www.Univexcorp.com

3 Old Rockingham Rd
Salem, NH 03079
United States of America

TEL: (800)258-6358
INTL TEL: (603)893-6191
FAX: (800)356-5614
INTL FAX: (603)893-1249