

"FBLGR5" BUDGET STAINLESS STEEL TOP WORK TABLES

18GA Top w/Galvanized Legs & Adjustable Undershef - 5" Riser

FEATURES:

- 18GA Stainless Steel Top
W/5" Rear Riser & Turndown
- Type 430 Stainless Steel With Satin Finish
- Top Is Sound Deadened
- Reinforced With 1"X2" Channel Running Entire Length Of Table
- 1-1/2" Stallion Edge On Front Side Edges
90° Bend Down For Table Line-Up
- Galvanized Base And Adjustable Undershef
- Adjustable Bullet Feet
- Shipped Knocked-Down, Easy-To-Assemble

SPECIFICATIONS:

- Top: Stainless Steel Tops Are Tig Welded, Exposed Welds Are Polished To Match Adjacent Surface
- Top: 18GA Stainless Steel Type 430 Stainless Steel Mechanically Polished With Satin Finish
- Shelf: 18GA Galvanized Steel
- Legs: 1-5/8" Round O.d. 16GA Tubular Galvanized Steel
- Gussets: Galvanized Steel
- Feet: 1" Adjustable Plastic Bullet Feet



FBLGR54830

CERTIFICATIONS:



"FBLGR5" BUDGET STAINLESS STEEL TOP WORK TABLES

LENGTH	24" WIDE	WT (LBS)	30" WIDE	WT (LBS)
24"	FBLGR5-2424	40	-	-
30"	FBLGR5-3024	45	FBLGR5-3030	50
36"	FBLGR5-3624	50	FBLGR5-3630	56
48"	FBLGR5-4824	61	FBLGR5-4830	69
60"	FBLGR5-6024	71	FBLGR5-6030	82
72"	FBLGR5-7224	83	FBLGR5-7230	94
84"	FBLGR5-8424	103	FBLGR5-8430	126
96"	FBLGR5-9624	111	FBLGR5-9630	128

ALL DIMENSIONS ARE TYPICAL. TOLERANCE +/- .500". JOHN BOOS & CO. RESERVES THE RIGHT TO CHANGE SPECIFICATIONS WITHOUT NOTICE.

DETAILED SPECIFICATIONS

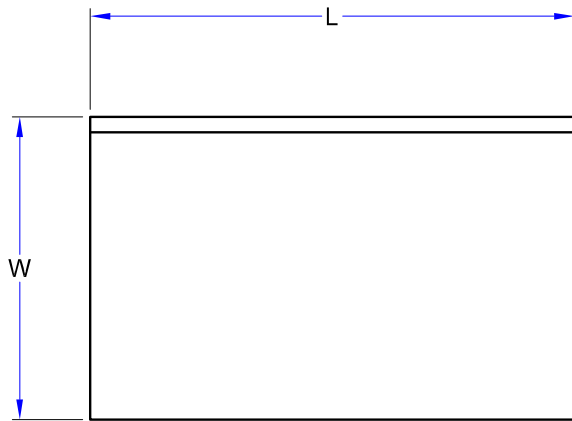

Units 7 Ft. & Larger Are
Furnished With Six Legs
Shelf Length = Length Minus 4.875"
Shelf Width = Width Minus 4.25"

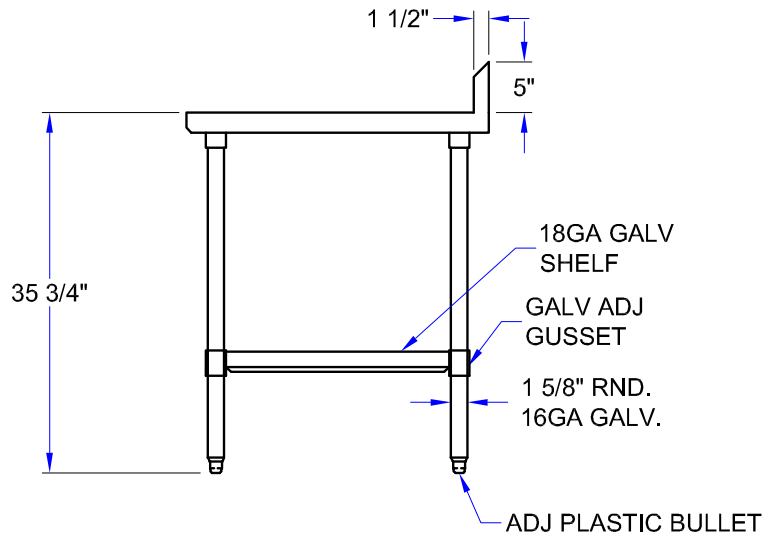
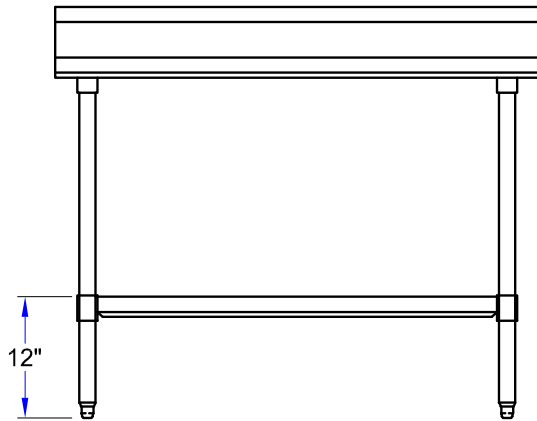

"FBLGR5" BUDGET STAINLESS STEEL TOP WORK TABLES

LENGTH	24" WIDE	WT (LBS)	30" WIDE	WT (LBS)
24"	FBLGR5-2424	40	-	-
30"	FBLGR5-3024	45	FBLGR5-3030	50
36"	FBLGR5-3624	50	FBLGR5-3630	56
48"	FBLGR5-4824	61	FBLGR5-4830	69
60"	FBLGR5-6024	71	FBLGR5-6030	82
72"	FBLGR5-7224	83	FBLGR5-7230	94
84"	FBLGR5-8424	103	FBLGR5-8430	126
96"	FBLGR5-9624	111	FBLGR5-9630	128

ALL DIMENSIONS ARE TYPICAL. TOLERANCE +/- .500". JOHN BOOS & CO. RESERVES THE RIGHT TO CHANGE SPECIFICATIONS WITHOUT NOTICE.