

"ST4R5-SBK" STAINLESS STEEL TOP WORK TABLES

14GA Top w/5" Riser & Stainless Steel Legs & Adjustable Bracing

FEATURES:

- 14GA Stainless Steel Top w/5" Riser & Turndown
- Type 300 Stainless Steel With #4 Polish, Satin Finish
- Top Is Sound Deadened
- Reinforced With 1"x2" Channel Running Entire Length Of Table
- 1-1/2" Stallion Edge On Front Side Edges 90 Degree Bend Down For Table Line-Up
- Stainless Steel Base With Adjustable Bracing
- Adjustable Bullet Feet
- Shipped Knocked-Down, Easy-To-Assemble

SPECIFICATIONS:

- Top: Stainless Steel Tops Are Tig Welded, Exposed Welds Are Polished To Match Adjacent Surface
- Top: 14GA Stainless Steel Type 300 Stainless Steel With #4 Polish, Satin Finish
- Bracing: 1-1/4" Round O.D. 18GA Stainless Steel
- Legs: 1-5/8" Round O.D. 16GA Tubular Stainless Steel
- Gussets: Stainless Steel
- Feet: 1" Adjustable Stainless Bullet Feet



ST4R5-3048SBK

CERTIFICATIONS:



ACCESSORIES

DESCRIPTION

- Drawer
- Drawer Lock
- Casters
- Overshelves
- Sinks
- Pot Rack

"ST4R5-SBK" STAINLESS STEEL TOP WORK TABLES

LENGTH	24" WIDE	WT	WT CAP	30" WIDE	WT	WT CAP	36" WIDE	WT	WT CAP
24"	ST4R5-2424SBK	44	900	ST4R5-3024SBK	49	900	ST4R5-3624SBK	55	900
30"	ST4R5-2430SBK	49	900	ST4R5-3030SBK	55	900	ST4R5-3630SBK	63	900
36"	ST4R5-2436SBK	55	900	ST4R5-3036SBK	61	900	ST4R5-3636SBK	70	900
48"	ST4R5-2448SBK	66	900	ST4R5-3048SBK	74	900	ST4R5-3648SBK	84	900
60"	ST4R5-2460SBK	77	650	ST4R5-3060SBK	87	650	ST4R5-3660SBK	97	650
72"	ST4R5-2472SBK	89	420	ST4R5-3072SBK	99	420	ST4R5-3672SBK	112	420
84"	ST4R5-2484SBK	108	1350	ST4R5-3084SBK	121	1350	ST4R5-3684SBK	138	1350
96"	ST4R5-2496SBK	119	1350	ST4R5-3096SBK	134	1350	ST4R5-3696SBK	153	1350
108"	ST4R5-24108SBK	129	1350	ST4R5-30108SBK	146	1350	ST4R5-36108SBK	166	1350
120"	ST4R5-24120SBK	141	1200	ST4R5-30120SBK	159	1200	ST4R5-36120SBK	180	1200
132"	ST4R5-24132SBK	152	960	ST4R5-30132SBK	171	960	ST4R5-36132SBK	195	960
144"	ST4R5-24144SBK	164	750	ST4R5-30144SBK	185	750	ST4R5-36144SBK	211	750

OVERALL WEIGHT (WT) AND MAX WEIGHT CAPACITY (WT CAP) ARE IN POUNDS (LBS). MAX WEIGHT CAPACITY EVENLY DISTRIBUTED. ALL DIMENSIONS ARE TYPICAL. TOLERANCE +/- .500". JOHN BOOS & CO. RESERVES THE RIGHT TO CHANGE SPECIFICATIONS WITHOUT NOTICE.

DETAILED SPECIFICATIONS

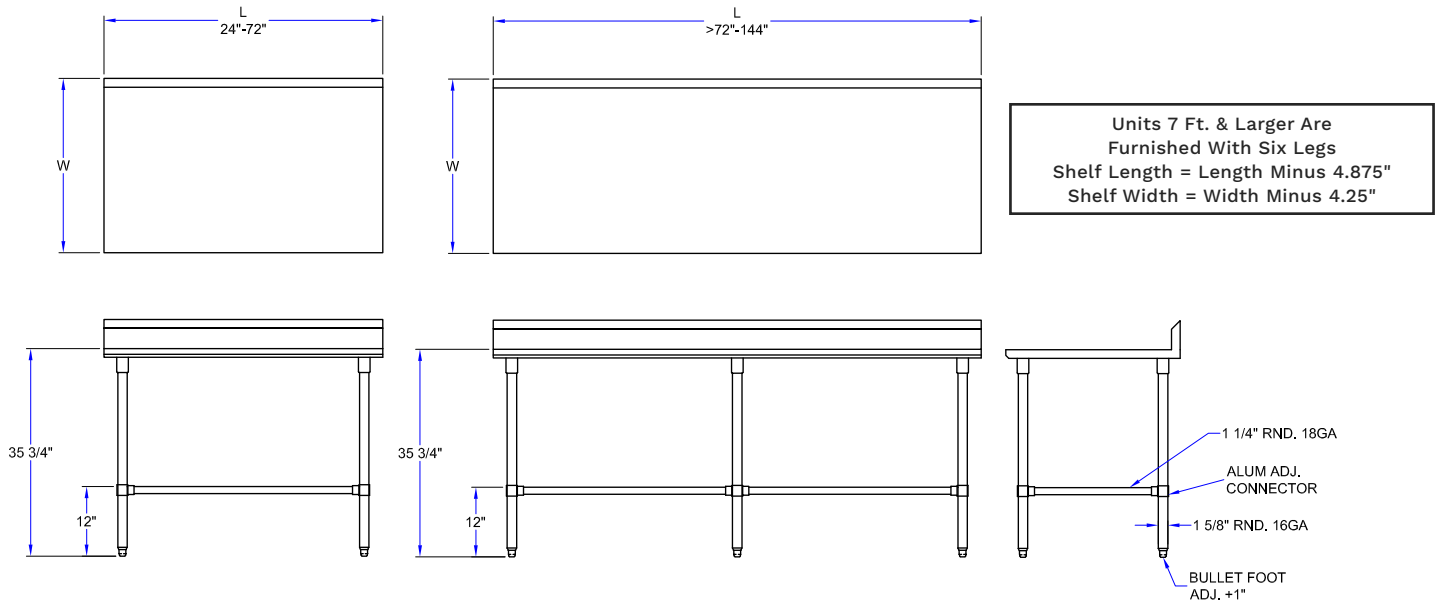

MODEL # STRUCTURE

5 = Ht. Of Riser w/Turndown
 R = Top w/Riser
 4 = 14GA Work Surface
 ST = Stainless Steel Top



24 = Width Of Work Surface
 30 = Length Of Work Surface
 SB = Stainless Legs & Bracing
 K = Ships Knocked Down

"ST4R5-SBK" STAINLESS STEEL TOP WORK TABLES

LENGTH	24" WIDE	WT	WT CAP	30" WIDE	WT	WT CAP	36" WIDE	WT	WT CAP
24"	ST4R5-2424SBK	44	900	ST4R5-3024SBK	49	900	ST4R5-3624SBK	55	900
30"	ST4R5-2430SBK	49	900	ST4R5-3030SBK	55	900	ST4R5-3630SBK	63	900
36"	ST4R5-2436SBK	55	900	ST4R5-3036SBK	61	900	ST4R5-3636SBK	70	900
48"	ST4R5-2448SBK	66	900	ST4R5-3048SBK	74	900	ST4R5-3648SBK	84	900
60"	ST4R5-2460SBK	77	650	ST4R5-3060SBK	87	650	ST4R5-3660SBK	97	650
72"	ST4R5-2472SBK	89	420	ST4R5-3072SBK	99	420	ST4R5-3672SBK	112	420
84"	ST4R5-2484SBK	108	1350	ST4R5-3084SBK	121	1350	ST4R5-3684SBK	138	1350
96"	ST4R5-2496SBK	119	1350	ST4R5-3096SBK	134	1350	ST4R5-3696SBK	153	1350
108"	ST4R5-24108SBK	129	1350	ST4R5-30108SBK	146	1350	ST4R5-36108SBK	166	1350
120"	ST4R5-24120SBK	141	1200	ST4R5-30120SBK	159	1200	ST4R5-36120SBK	180	1200
132"	ST4R5-24132SBK	152	960	ST4R5-30132SBK	171	960	ST4R5-36132SBK	195	960
144"	ST4R5-24144SBK	164	750	ST4R5-30144SBK	185	750	ST4R5-36144SBK	211	750

OVERALL WEIGHT (WT) AND MAX WEIGHT CAPACITY (WT CAP) ARE IN POUNDS (LBS). MAX WEIGHT CAPACITY EVENLY DISTRIBUTED.
 ALL DIMENSIONS ARE TYPICAL. TOLERANCE +/- .500". JOHN BOOS & CO. RESERVES THE RIGHT TO CHANGE SPECIFICATIONS WITHOUT NOTICE.