

## DINEXPRESS HOT FOOD COUNTERS – HEAT IN BASE

Compliant with  
NSF/ANSI Standard 2

### Item Numbers

DXP2HFHIB  
DXP3HFHIB  
DXP4HFHIB  
DXP5HFHIB  
DXP6HFHIB



DXP5HFHIB

The Heat-In-Base System is a built-in option which permits handy storage of prepared foods directly under your DineXpress hot food wells. Pan rack assemblies are provided to allow storage of standard 12" x 20" food pans. Each pan rack assembly will accommodate the following full size pans: 6 - 2-1/2" deep pans or 3 - 4" deep pans or 2 - 6" deep pans.

Dinex equipment has the advantage of Food Safe technology and certification. This ensures that your food is kept out of the danger zone. Food spoilage occurs mainly because of rapidly accelerated bacteriological activity within the 40°F-140°F danger zone

With Food Safe technology, hot food stays above 140°F longer and cold food is kept below 40°F. Both are key factors in HACCP compliance and the fight against foodborne pathogens.

### ELECTRICAL

- Temperature in the Heat-In-Base unit is controlled by a single thermostat. Heating elements are 500 watt tubular type. The Heat-In-Base is electrically interwired to the base unit thus one common cord and plug is provided. The availability of the Heat-In-Base option is dependent upon total amperage of the base unit plus the Heat-In-Base option.
- Drain valve exits operator's left side as standard. Drain valve is 3/4" FPT.
- Two and three well units are available in 120, 208, 240 volts, single phase standard
- Eight foot electrical cord and plug

### DIMENSIONS

DXP2HFHIB - 36"H x 28"D x 32"L  
DXP3HFHIB - 36"H x 28"D x 46"L  
DXP4HFHIB - 36"H x 28"D x 60"L  
DXP5HFHIB - 36"H x 28"D x 74"L  
DXP6HFHIB - 36"H x 28"D x 88"L  
36" height on all standard units

### COMMON OPTIONS

- Pizzazz powder coating in lieu of stainless steel

### ASSEMBLY STRUCTURE

Double wall stainless steel hinged doors provided. Doors insulated with one inch density insulation. Each door hinged and provided with a magnetic catch and recessed door pull. Heat-In-Base sides and back are double wall construction and insulated with high density fiberglass insulation.

### WARRANTY

One year parts and labor.

# DINEXPRESS HOT FOOD COUNTERS – HEAT IN BASE

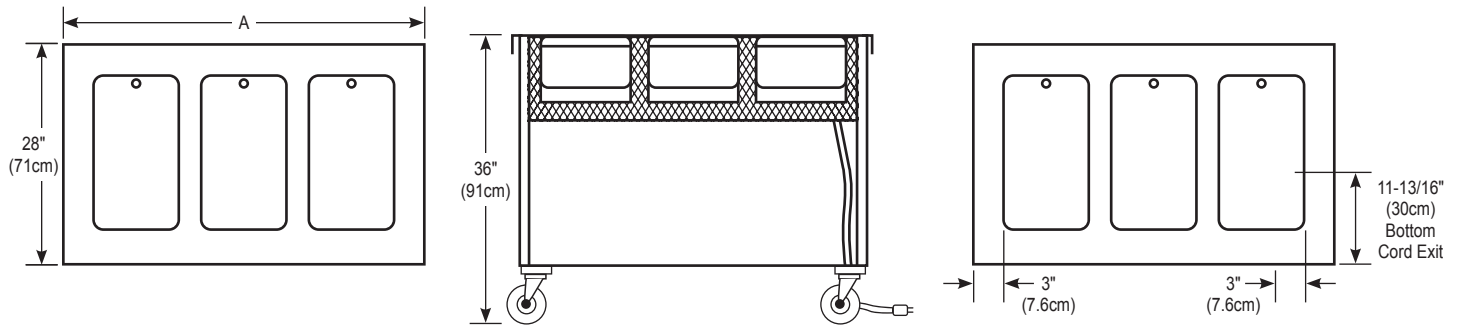

## Items and Dimensions

ITEM NUMBER	NO. OF DOORS	LENGTH (A)	WIDTH	HEIGHT	NO. PAN RACK ASSY'S	WATTS	AMPS (SINGLE PHASE)			NEMA CAP NUMBER			SHIP WEIGHT (LBS)
							120V	208V	240V	120V	208V	240V	
DXP2HFHIB	1	32" (81cm)	28" (71cm)	36" (91cm)	1	3000	25	14.4	12.5	5-50P	6-15P	6-15P	300
DXP3HFHIB	2	46" (117cm)	28" (71cm)	36" (91cm)	2	4500	37.5	21.6	18.7	5-50P	6-30P	6-30P	310
DXP4HFHIB	2	60" (152cm)	28" (71cm)	36" (91cm)	2	5500	N/A	26.4	22.9	N/A	6-50P	6-30P	335
DXP5HFHIB	2	74" (188cm)	28" (71cm)	36" (91cm)	2	7000	N/A	33.6	29.2	N/A	6-50P	6-50P	375
DXP6HFHIB	3	88" (224cm)	28" (71cm)	36" (91cm)	3	8000	N/A	38.5	33.3	N/A	6-50P	6-50P	400

Each pan rack assembly will accommodate the following full size 12" x 20" pans:

6 each 2-1/2" D OR 3 each 4" D OR 2 each 6" D

Please confirm that you have the most current specification sheet by visiting [www.dinex.com](http://www.dinex.com).

It is Dinex's policy to offer equipment which is design certified by companies that have been accredited at the federal level by the Occupational Safety and Health Agency (OSHA) and ANSI as a national recognized testing laboratory. These companies include CSA International, Underwriters Laboratories, Edison Testing Laboratories and National Sanitation Foundation. However, a continuing program of product improvement makes it necessary to submit new models to the agencies as they are developed. Consequently, all models may not bear the appropriate labels at all times.

Dinex reserves the right to change specifications and product design without notice. Such revisions do not entitle the buyer to corresponding changes, improvements, additions or replacements for previously purchased equipment.

