

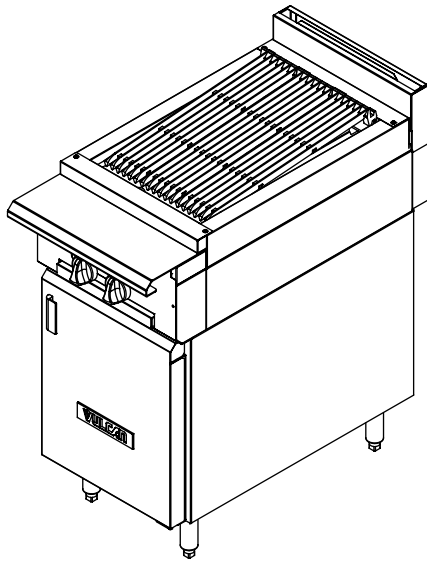

Project \_\_\_\_\_  
 AIA # \_\_\_\_\_ SIS # \_\_\_\_\_  
 Item # \_\_\_\_\_ Quantity \_\_\_\_\_ C.S.I. Section 114000

# HEAVY DUTY GAS RANGE

## 18" Wide Charbroiler Gas Range



**Model VCBB18B**  
 Shown on cabinet base



### SPECIFICATIONS

18" wide heavy duty gas range, Vulcan model No. VCBB18 (modular), VCBB18B (cabinet base). Stainless steel front, front top ledge, burner box, sides, base, stub back and 4" adjustable legs. 1¼" diameter front gas manifold. Three burners, totaling 49,000 BTU/hr. Cast burners and char-radiants with stainless steel supercharger burner dividers. Individual pilots and controls for each burner. Heavy duty cast slant grates, easy lift-off (3 each for 18" wide models), 3/4" rear gas connection.

Total input 49,000 BTU/hr.

#### Exterior Dimensions:

36¾"D x 18"W x 40½"H on 4" adjustable legs

### MODELS

- VCBB18** 18" Wide Charbroiler / Modular
- VCBB18B** 18" Wide Charbroiler / Cabinet Base

### STANDARD FEATURES

- Stainless steel front, front top ledge, burner box, sides, base, and stub back
- 1¼" Diameter front gas manifold with ¾" rear gas connection (capped)
- 49,000 BTU/hr. (3 burners)
- Individual pilots and controls for each burner
- Heavy-duty slant cast grates and char-radiants
- Stainless steel supercharger burner dividers
- 4" stainless steel stub riser
- 6" adjustable stainless steel legs for "B" models (no legs for modular model)
- Stainless steel cabinet base door
- Universal rack guides, with one removable shelf (cabinet base)
- One year limited parts and labor warranty

### FACTORY-INSTALLED OPTIONS

- Cap and cover front manifold
- 4" adjustable flanged feet for modular models
- Less legs for dolly mounting of cabinet base models
- 3" high toe base for curb mounting of cabinet base models
- Universal rack guides, with one shelf (shelf is removable)

### ACCESSORIES (PACKAGED AND SOLD SEPARATELY)

- ¾", 1", or 1¼" gas pressure regulator (specify gas type – pack loose)
- Set of 4 casters (two locking), 6" high
- Extra removable shelves for use with Universal rack guides (cabinet base)
- 6" adjustable flanged feet for cabinet base models
- Banking strip
- 10", 22", or 34" high back risers (no shelf)
- Common condiment type, telescoping plate rails (starting at 24" length)
- Flexible gas hose with quick disconnect and restraining device

HEAVY DUTY GAS RANGE – 18" Wide Charbroiler Gas Range

Approved by \_\_\_\_\_ Date \_\_\_\_\_ Approved by \_\_\_\_\_ Date \_\_\_\_\_

### INSTALLATION INSTRUCTIONS

1. A properly sized gas pressure regulator suitable for battery or single unit application must be furnished and installed. Natural gas 6.0" W.C., propane gas 10.0" W.C.
2. An adequate ventilation system is required for commercial cooking equipment. Information may be obtained by visiting the National Fire Protection Association website at <https://www.nfpa.org/>. Refer to NFPA No. 96.
3. These units are manufactured for installation in accordance with ANSZ223.1A (latest edition), National Fuel Gas Code. Information may be obtained from The American Gas Association website at <https://www.aga.org/>.

4. For proper combustion, install equipment on adjustable legs or casters. On curb or platform, allow 3½" front overhang. Toe base with leveling bolts are required for curb installation. Specify when ordering.
5. Cannot be battered with GH series equipment.
6. This appliance is manufactured for commercial installation only and is not intended for home use.

**NOTE:** In line with its policy to continually improve its product, Vulcan reserves the right to change materials and specifications without notice.

#### Clearances

Combustible  
Non-combustible

#### Rear

10"  
0"

#### Sides

10"  
0"

**SPECIFY TYPE OF GAS WHEN ORDERING.**  
**SPECIFY ALTITUDE WHEN ABOVE 2,000 FEET.**

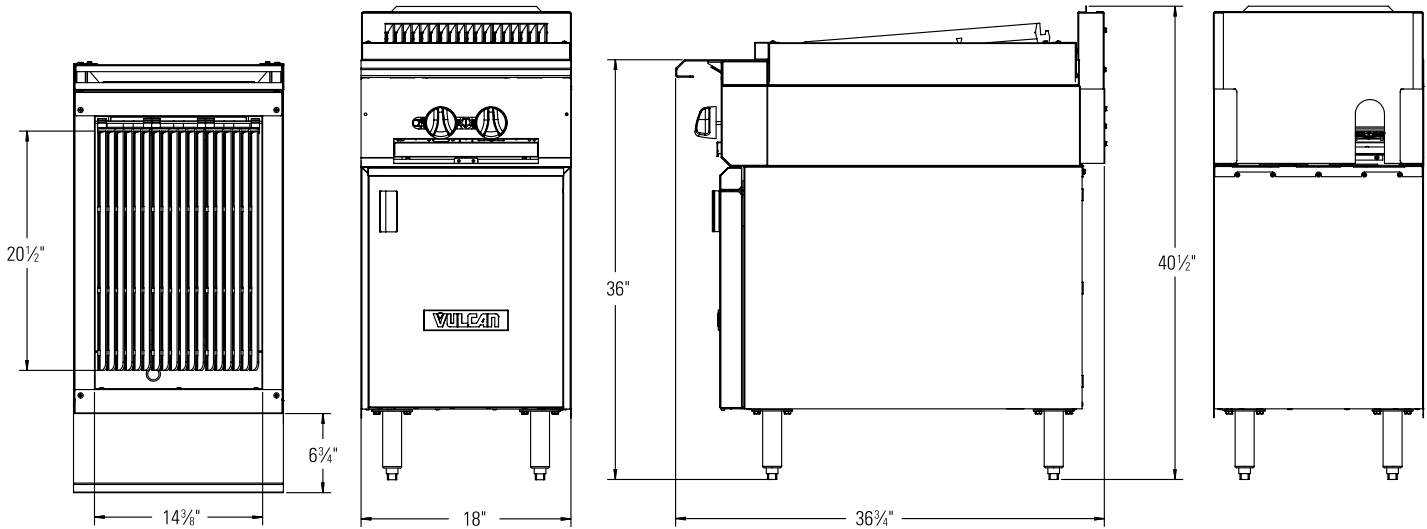

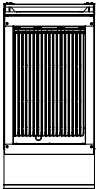
Top Configuration	Model	Description	Total Input BTU / Hr.	Shipping Weight Lbs. / KG
	<b>VCBB18</b>	18" Wide Charbroiler / Modular	49,000	245 / 111
	<b>VCBB18B</b>	18" Wide Charbroiler / Cabinet Base	49,000	255 / 116

As continued product improvement is a policy of Vulcan, specifications are subject to change without notice.