

WARING COMMERCIAL®

One Gallon Blender with Timer
and Spigot Container

CB15TSF

Unit Information

15.0 Amps. – 3.75 HP

3 Year Limited Motor Warranty

Electronic Membrane Keypad

Slow Start™ Blending Mechanism

Timer Adjustable from 10 seconds
to 3 minutes

Operating Cycle is 3 Min. ON
and 1 Min. OFF

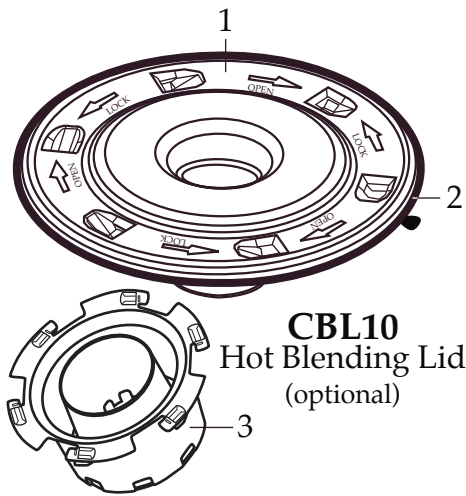

CBL10
Hot Blending Lid
(optional)

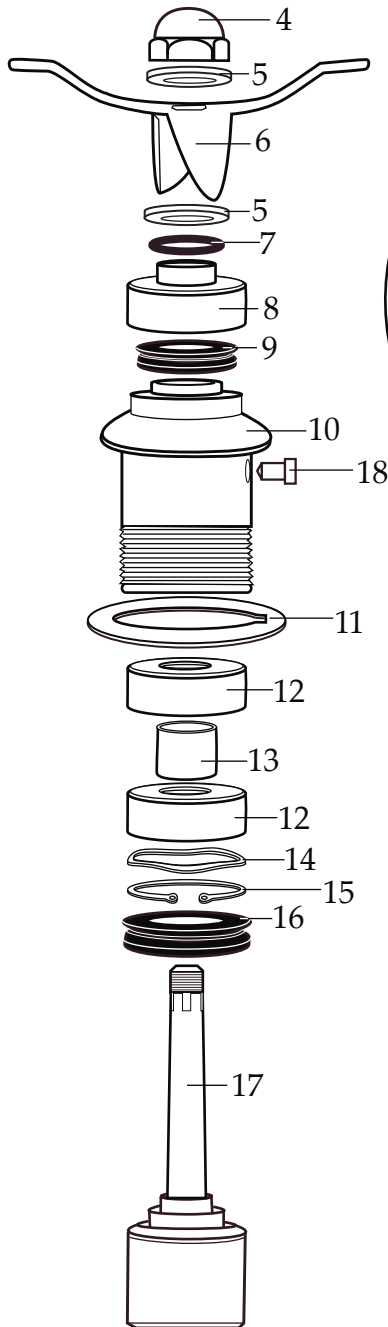
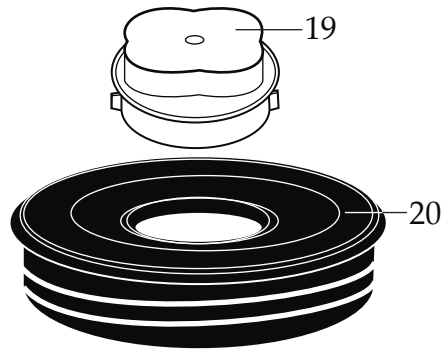

502977
Blending Assembly

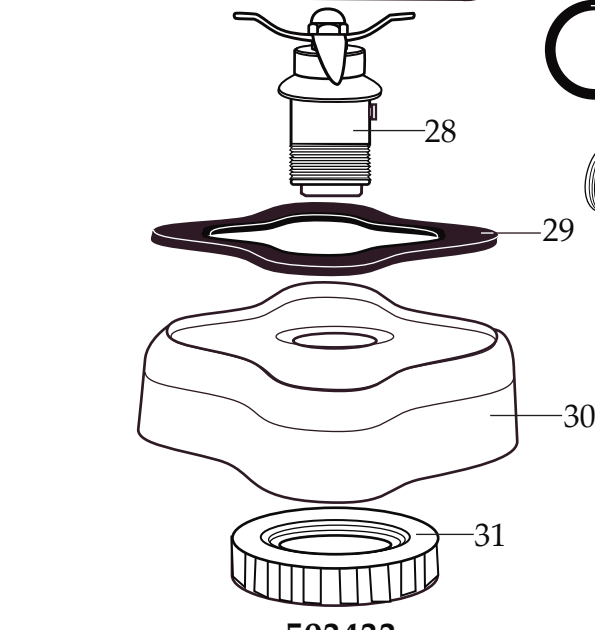
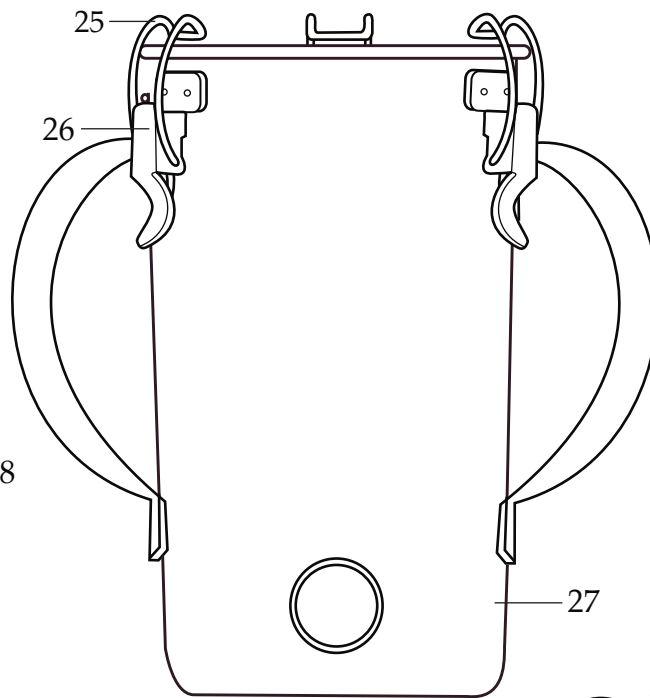

503433
Container with Blending Assembly and Spigot



013304
NSF Seal

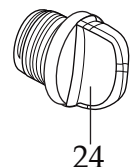
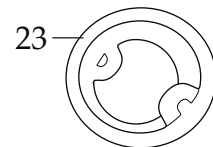
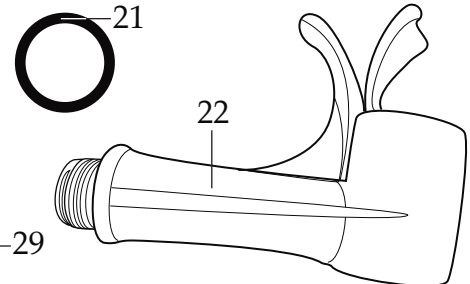

WARING COMMERCIAL®

Blender Unit Components CB15TSF

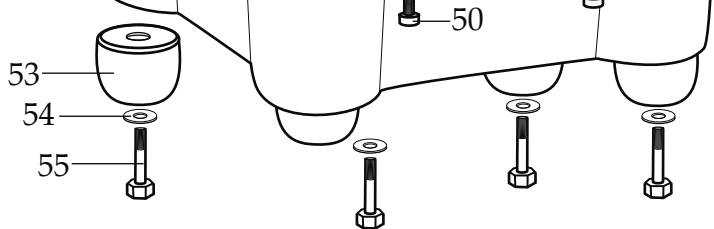
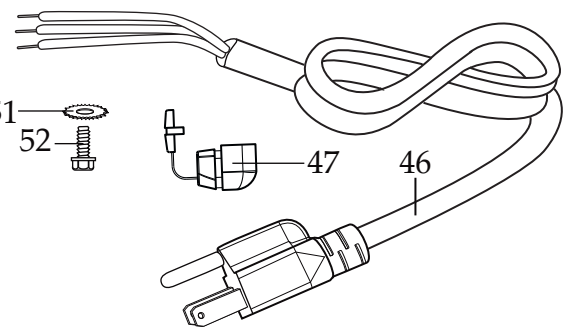
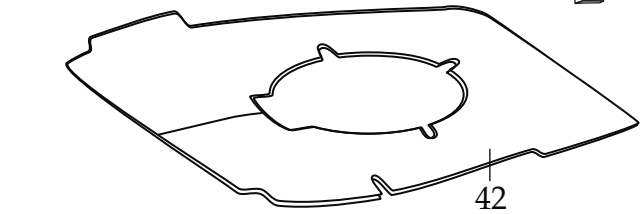
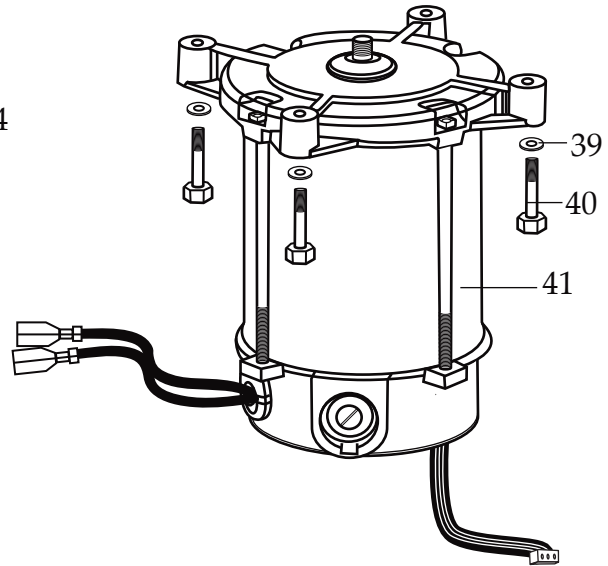
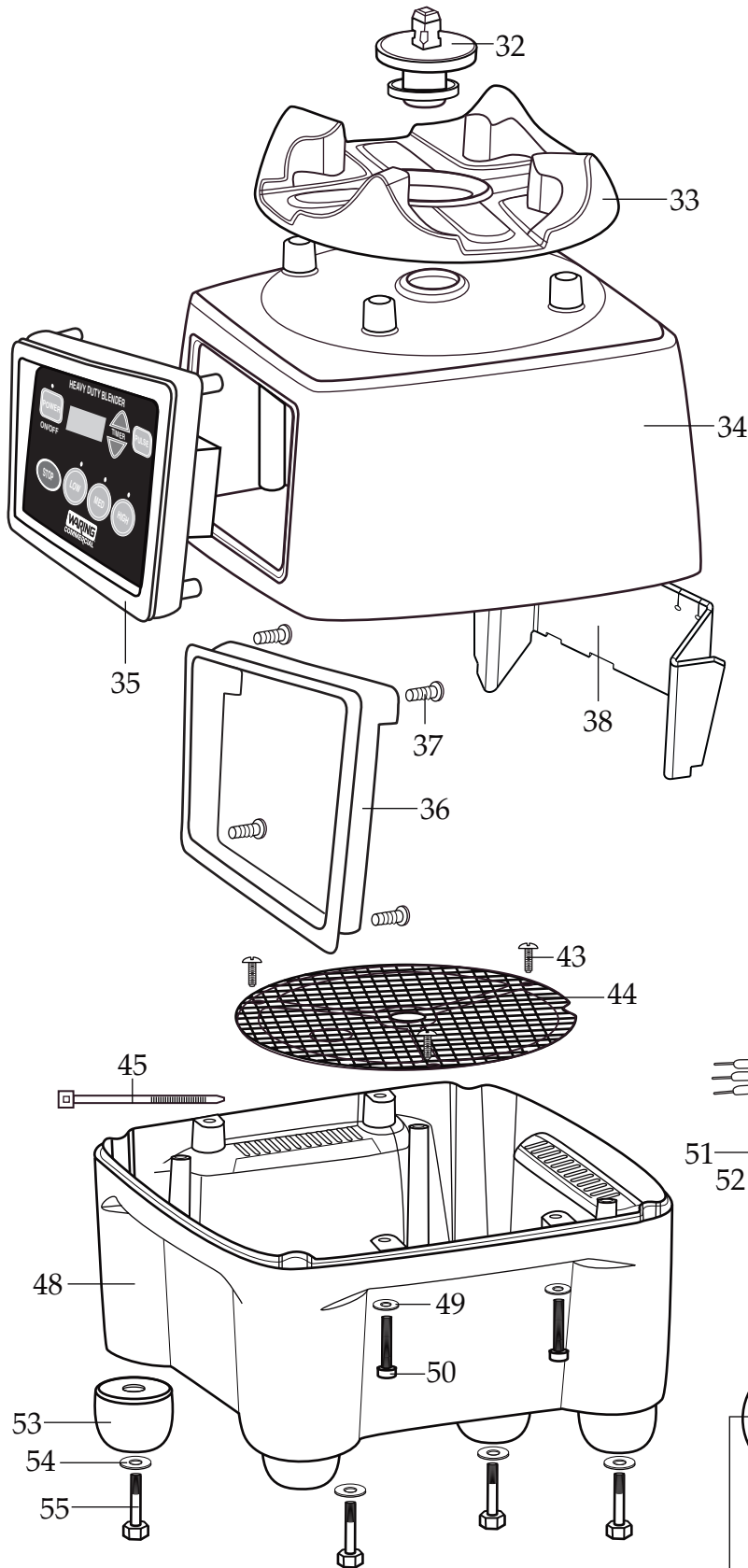

Wiring Diagram

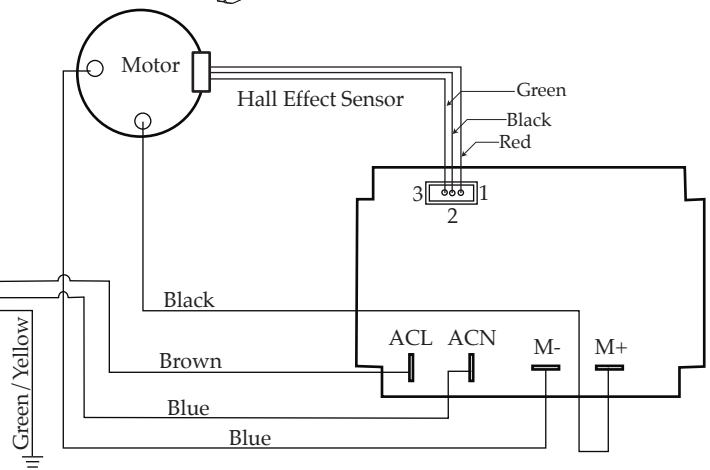

Catalog
 CB15TSF *(after 7/28/2016)* **Model**
 Convert Back CB15TG CB15T
 to CB15T *(after 3/29/2016)*



Illustration #	Part #	Description
1	024000	Hot Blending Outer Polycarbonate Lid
2	026496	Gasket
3	023998	Hot Blending Lid Baffle Cup
4	002972	Cap Nut
5	027581	Washer (2 required)
6	027683	Blade
7	018389	"O" Ring
8	027582	Bearing Cap
9	018390	Small "V" Ring
10	023934	Bearing Holder
11	004946	Washer
12	018386	Bearing (2 required)
13	023926	Spacer
14	023907	Spring Washer
15	023927	Retaining Ring
16	023906	Large "V" Ring
17	023933	Drive Shaft
18	025817	Key
19	028530	Cover Insert
20	028226	Vinyl Outer Lid
21	034026	"O" Ring
22	033965	Spigot Assembly
23	034320	Spigot Rubber Insert
24	034016	Spigot Plug
25	008791	Latch Wire (3 required)
26	502773	Bracket Assembly (spot welded to container 3 required)
27	023909	Double Handle Container
28	502977	Blending Assembly (complete)
29	004949	Container Base Gasket
30	025571	Container Support
31	012008	Lock Nut

Catalog
 CB15TSF (after 7/28/2016)
 Convert Back to CB15T

Model
 CB15TG (after 3/29/2016)
 CB15T



Illustration #	Part #	Description
32	503328	Coupling with Magnet Ring
33	025871	Jar Pad
34	028025	Top Housing
35	030895	Control Panel
36	029888	Rear Control Panel
37	026497	Screw (4 required)
38	030453	Control Panel Baffle
39	002984	Washer (4 required <i>on units after 7/28/2016</i>)
	003344	Washer (4 required <i>on units after 3/29/2016</i>)
	002984	Washer (4 required)
40	016691	Bolt (4 required <i>on units after 7/28/2016</i>)
	019098	Screw (4 required <i>on units after 3/29/2016</i>)
	016691	Bolt (4 required)
41	029875	ECM Motor with MTP (<i>on units after 7/28/2016</i>)
	503472	Motor Modified CB15 Groschopp (<i>on units after 3/29/2016</i>)
	026170	ECM Motor (<i>on units after 1/27/2016</i>)
	029875	ECM Motor with MTP
42	026318	Baffle (<i>on units after 7/28/2016</i>)
	035355	Baffle (<i>on units after 3/29/2016</i>)
	026318	Baffle
43	026500	Screw (6 required)
44	018791	Screen
45	013731	Cable Tie
46	503329	Cord Set
47	018811	Strain Relief
48	026317	Bottom Housing
49	002984	Washer (4 required)
50	026412	Screw (4 required)
51	002943	Ground Washer
52	027278	Ground Screw
53	026296	Foot (4 required)
54	018314	Washer (4 required)
55	026493	Screw (4 required)

Catalog
 CB15TSF *(after 7/28/2016)*
 Convert Back
 to CB15T

Model
 CB15TG CB15T
(after 3/29/2016)

Waring Factory Service Center
 314 Ella T. Grasso Ave.
 Torrington, CT 06790
 Tele. 1-800-269-6640

Fax 860-496-9017
 www.waringcommercialproducts.com

Groschopp Motor Parts No Longer Used
(on units after 3/29/2016 thru 7/28/2016)

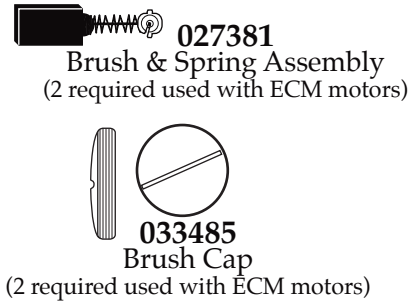
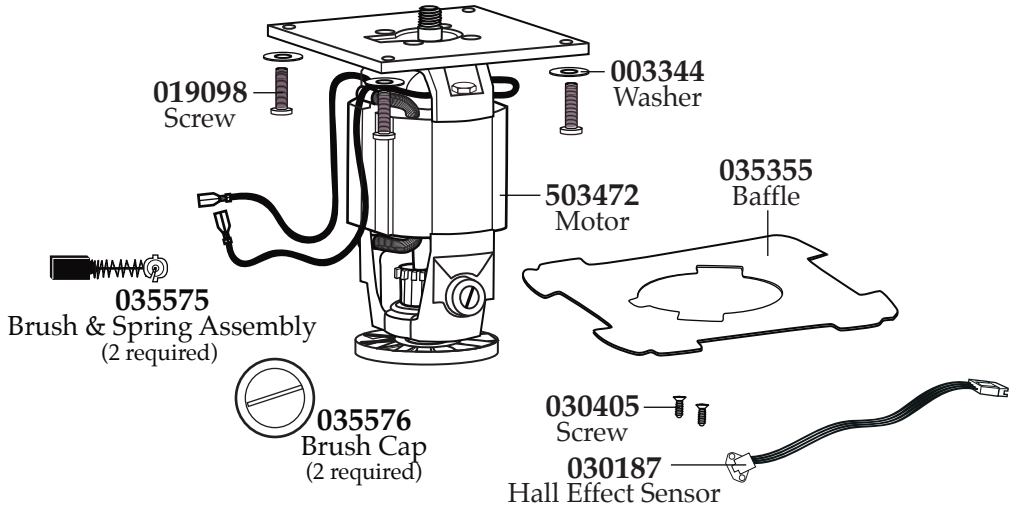

036445
CB15 Groschopp Motor Replacement Kit

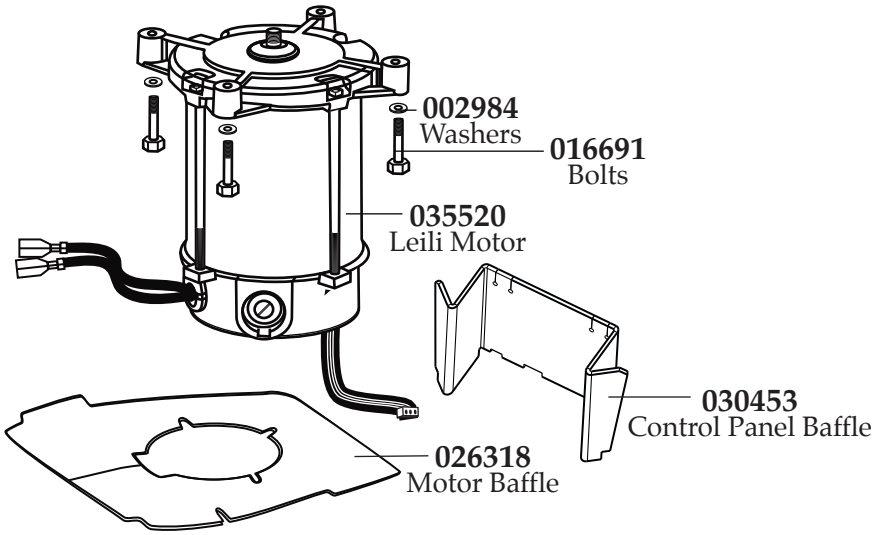

Part No Longer Used

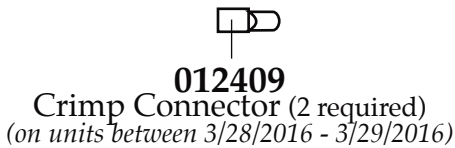

Wiring Diagram
(on units between 3/28/2016 - 3/29/2016)

