



WJX90E/K

Pulp Eject Juice Extractor



Pulp Eject Juice Extractor





MAIN FEATURES

- Heavy-duty centrifugal juice extractor with continuous pulp ejection
- Built for use in smoothie shops, bars, cafés, restaurants, hotels and healthcare establishments
- Stainless steel filter basket and shredder disc expertly designed for a fantastic yield to save operators money and produce less waste
- 1.2 HP brushless induction motor
- 3,600 RPM
- Powder-coated, die-cast metal housing with stainless steel filter basket and shredder disc
- 8 cm feed chute opening can fit whole apples and hold a large capacity of fruits and vegetables
- Large, 11 L pulp container allows for continuous operation
- Juicing spout height accommodates a 1.4 L blender jar
- Safety interlock features
- Rotating, no-drip spigot reduces mess
- Includes cleaning brush

ELECTRICAL

Voltage: 220/240V

Frequency: 50 Hz

Plug Type: WJX90E – F 
WJX90K – G 

Cord Length: 1.8 meters



SALES FEATURES

Add fresh juice to your menu easily and efficiently with the Waring Commercial® Pulp Eject Juice Extractor. The brushless induction motor gives it the power to quickly and thoroughly juice fruits and vegetables for smoothies, and for making nutritious juices. Designed for continuous use, the machine is perfect for juice shops that serve juice all day. Compact size and quieter operation make this unit ideal for front-of-house usage.



@waringcommercial

©2022 Waring Commercial
314 Ella T. Grasso Avenue, Torrington, CT 06790
Tel. 800-492-7464 • Fax 860-496-9008

waringcommercialproducts.com

WJX90E/K



INCLUDED PARTS & ACCESSORIES



WJX80XP Food Pusher



WJX80XLID Cover



WJX80BKT Removable Filter Basket
With Handles



WJX80BA Bowl Attachment



WJX80BWL All-Stainless Steel Juice
Bowl



WJX80SP Juicing Spout



WJX80BIN Pulp Container



WJX80CB Cleaning Brush

OPTIONAL PARTS & ACCESSORIES



WJX80CHT Continuous Feed Chute

DIMENSIONS (CM)

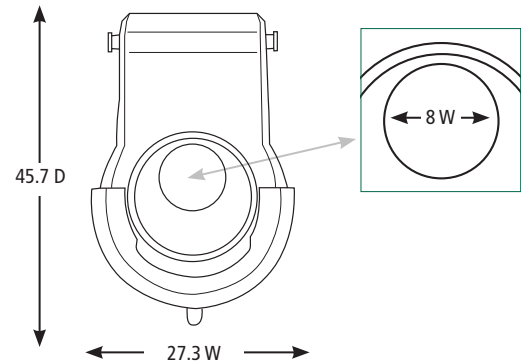
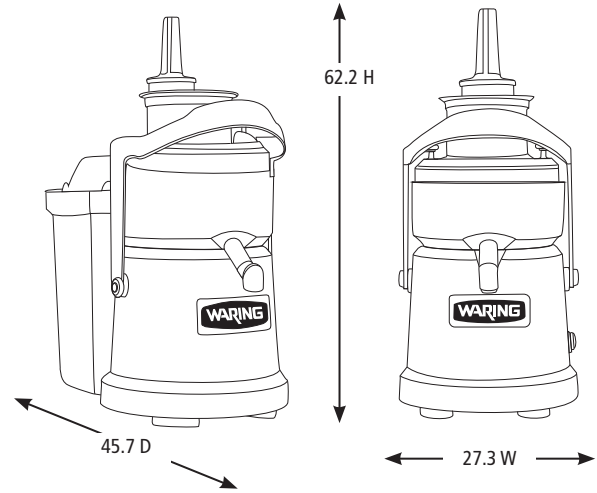

Out of Box Weight: 12.2 kg

ORDERING INFORMATION	#STD. PKG.	GIFTBOX WEIGHT (KG)	CUBIC METERS	BOX DIMENSIONS (CM) D x W x H	UPC	CASE PKG.	MC WEIGHT (KG)	MC DIMENSIONS (CM) D x W x H	MBC
WJX90E – Pulp Eject Juice Extractor	1	13.3	0.12	62.5 x 36.5 x 53.6	040072096082	1	16.6	63.8 x 36.5 x 55.2	10040072096089
WJX90K – Pulp Eject Juice Extractor	1	13.3	0.12	62.5 x 36.5 x 53.6	040072096075	1	16.6	63.8 x 36.5 x 55.2	10040072096072



@waringcommercial

©2022 Waring Commercial
314 Ella T. Grasso Avenue, Torrington, CT 06790
Tel. 800-492-7464 • Fax 860-496-9008

waringcommercialproducts.com

21WI080028 / REV 11/21