

CBS-62H Coffee Brewer

**Maritime Version
Rated IP44**



Driven To Pioneer Innovation™

Table of Contents

| | | | |
|---------------------------------------|---|-----------------------|----|
| Contact Information | 2 | Service..... | 7 |
| Product Description/Features | 2 | Wiring Diagram..... | 12 |
| Specifications..... | 2 | Dispenser Parts | 13 |
| Dimensions & Utility Connections..... | 3 | Brewer Parts | 14 |
| Installation..... | 4 | Troubleshooting..... | 17 |
| Operating Procedures | 6 | | |

FETCO® LUXUS® and Driven To Pioneer Innovation™ are trademarks or trade names of Food Equipment Technologies Company.

Contact Information

FETCO

Food Equipment Technologies Company
600 Rose Road
Lake Zurich • IL • 60047-0429 • USA

Internet: www.fetco.com

Phone: (800) 338-2699 (US & Canada)
(847) 719-3000

Fax: (847) 719-3001

Email: sales@fetco.com
techsupport@fetco.com

Product Description/Features

- Maritime Version with IP44 Ingress Protection Rating
- 3 gallon, thermal, portable, all stainless steel dispensers
- Stainless steel, gourmet size brew baskets
- Fully automatic, with electronic temperature control
- Open type, leak free dispense system
- Brew basket double safety locks
- Two level tank drain system
- Total serviceability from the front

Specifications

Brew Volume:

Full Batch 3 gal. (11.4 lit.)
Half Batch 1.5 gal. (5.7 lit.)

Brew Time:

Full Batch 5 - 5.5 min.
Half Batch 2.5 - 2.75 min.
(Allow an extra 2-4 minutes for coffee to finish dripping)

Coffee Filter Size: 20" X 8" – Product # F004
18" X 7½" - optional half batch Product # F005

Temperature:

205°F inside water tank (at sea level)
195°F ± 5° at sprayhead

Bypass Range: 0 to 33%

(Factory set at 0% unless specified)

Water Requirements:

20-75 psig, 2 gpm

Weights and Capacities

| Brewer Model | Weight (empty) | Water tank Capacity & Weight | | Weight (filled) | Dispenser Weight, ea. | Dispenser Filled, ea. | Total Weight Brewer & Dispensers, Filled |
|--------------|----------------|------------------------------|------------|-----------------|-----------------------|-----------------------|--|
| CBS-62H | 195 lbs. | 14 gal. | 116.2 lbs. | 311.2 lbs. | 18 lbs. | 42.5 lbs. | 397 lbs. |

Electrical Configuration and Brewing Efficiency

| Electrical Code | Heater Configuration | Voltage Connection | Phase | Wires | KW | Maximum Amp draw | Batches per Hour | |
|-----------------|----------------------|--------------------|-------|------------|------|------------------|------------------|-----------|
| | | | | | | | Cold Water | Hot Water |
| C62186MIP | 6 X 4000 W | 440 | three | 3 + ground | 20.1 | 27.4 | 17.3 | 18.0 |
| | | 480 | three | 3 + ground | 24.1 | 29.7 | 18.0 | 18.0 |
| C62196MIP | 3 X 4000 W | 440 | three | 3 + ground | 10.1 | 13.7 | 8.6 | 18.0 |
| | | 480 | three | 3 + ground | 12.1 | 14.9 | 9.9 | 18.0 |

Dimensions & Utility Connections

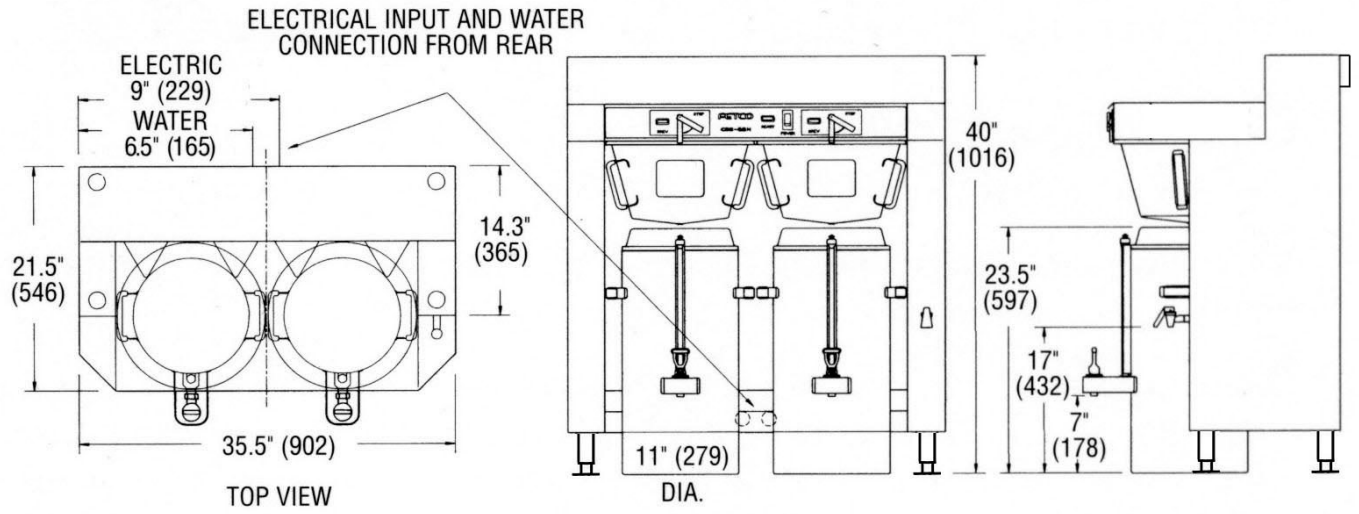

Installation

(For Qualified Service Technicians Only)

Keys To A Successful Installation

If not installed correctly by qualified personnel, the brewer may not operate properly and damage may result. Damages resulting from improper installation are not covered by the warranty.

Here are the key points to consider before installation:

Electrical:

- ❖ The power switch has a built-in circuit breaker. To reset it, turn to the “off” position, and then back to the “on” position.
- ❖ The electrical drawing for the brewer is located on the inside of the lower cover.

Plumbing:

- ❖ This equipment is to be installed to comply with the applicable federal, state, or local plumbing codes.
- ❖ The water line must be flushed thoroughly prior to connecting it to the brewer to prevent debris from contaminating the machine.
- ❖ Verify that the water line will provide at least 2 gallons per minute before connecting it to the brewer.

Installation Instructions

Brewer Setup

1. Review the Dimensions for the unit you are installing. Verify that the brewer will fit in the space intended for it, and that the counter or table will support the total weight of the brewer and dispensers when filled.
2. The brewer's legs are shipped inside the brew baskets. Remove the brew basket(s) and the coffee dispenser(s). Place the brewer on its back and screw in the legs.
3. Place the brewer on the counter or stand.
4. When the brewer is in position, level it front to back as well as side-to-side by adjusting the legs.
5. Mark the surface of the counter with the location of the mounting holes in the legs.
6. Drill $\frac{1}{4}$ " diameter holes in the counter and secure the legs to the counter with bolts and nuts (not included).
7. Remove the lower cover to access the water and electrical connections.



Warning: Legs are to be adjusted for leveling the brewer only. Do not use for height adjustment or extend them higher than necessary.

Server Ring Installation

1. Place a LUXUS dispenser in the proper position under each brew basket.
2. Mark the surface of the counter top with the circular outline of the dispenser bottom.
3. Remove the dispenser and place a mark at the exact center of the circle.
4. Drill a $\frac{1}{4}$ " hole in the center of the circle.
5. Insert the threaded stud on the bottom of the server ring into the hole and secure it with the wing nut provided.
6. To install the server rings away from the brewer, place the dispensers in the desired location and follow steps 2 through 5.

Top Cover Instructions

1. Remove all screws. The back edge of the top cover fits tightly over the vents on the back of the brewer. Carefully lift the front of the cover up and back.
2. Once the cover is at a 45° angle, it can be lifted completely off.
1. To replace the cover, hold the cover at approximately a 45° angle and place the back edge over the vents on the back of the brewer.
2. Lower the front of the cover while pulling it over the top of the brewer. The cover should flex slightly. Install all screws.

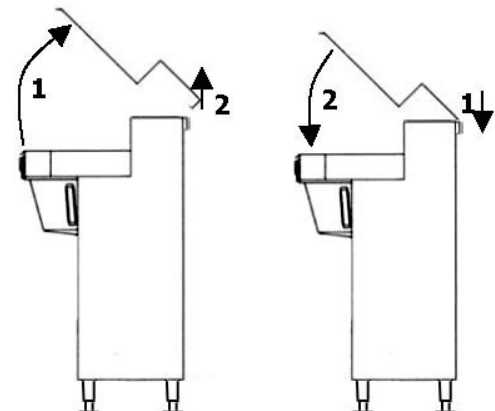

Water Connection

1. The water inlet is a 3/8 inch male flare fitting. Insert the water line through the splash-proof grommet on the back of the brewer and attach it to the fitting.
2. The brewer can be connected to a cold or hot water line. Cold water is preferred for best coffee flavor, but hot water will allow for faster recovery times.
3. Install a water shut off valve near the brewer to facilitate service. If an in-line water filter is used, it should be installed after the water shut off valve and in a position to facilitate filter replacement.
4. Flush the water supply line and filter **before** connecting it to the brewer.
5. Verify that the water line will provide at least 2 gallons per minute and that the water pressure is between 20 and 75 psig.

Electrical Connections

1. Verify that the actual voltage at the electrical service connection is compatible with the specifications on the brewer's serial number label.
2. The temperature and water tank fill level are pre-set at the factory. There is no need to turn off the heaters during the installation process. The control board disables the heaters until the tank is full of water. The heating process will start automatically when the tank has filled.
3. A fused disconnect switch or circuit breaker on the incoming power line must be conveniently located near the brewer, and its location known to the operators.
4. The body of the brewer must be grounded to a suitable ground. A ground lug is provided in the brewer next to the terminal block. Use only 10 gauge copper wire.
5. Electrical connections must be secured in-place within the unit to meet national and local standards.
6. Finally, connect the incoming power wires to the terminal block in accordance with applicable codes.

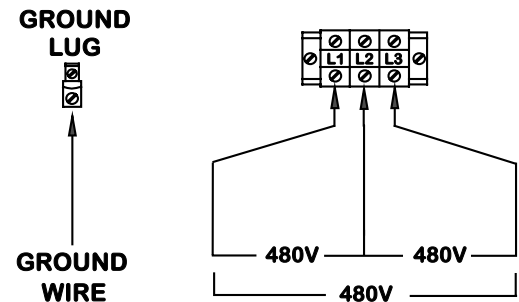
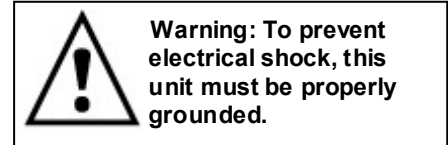

Final Setup

1. Turn on the incoming water supply line and inspect both inside and outside of the brewer for leaks in all fittings and tubes
2. Turn on the incoming power.
3. Turn on the brewer's main power switch.
4. Within 6 seconds, the hot water tank will begin filling until the probe at the top of the tank senses the water.
5. The control board will disable the heaters until the tank is full.
6. The brewer will be ready for operation as soon as the ready light comes on to show that the water tank is up to temperature. The time required to reach brewing temperature will vary according to the electrical configuration ordered.
7. Review the Operating Instructions. Brew one full batch (water only) on each side to confirm proper fill levels. The brewer is factory set with water only (no coffee) to dispense the correct amount of water.
8. Re-attach the covers after one final inspection for leaks. Look closely in the top of the brewer at the dispense fittings during this inspection.

Operating Training

Review the operating procedures with whoever will be using the brewer. Pay attention to the following areas:

1. Always pre-heat the dispensers before the first use of each day by filling them half way with hot water, and letting them stand for at least 15 minutes.
2. Don't remove the brew basket until it has stopped dripping.
3. Make sure the dispenser is empty before brewing into it.
4. Show how to attach covers, close, and or secure the thermal dispensers for transporting.
5. Show the location and operation of the water shut off valve as well as the circuit breaker for the brewer.
6. Steam from the tank will form condensation in the vent tubes. This condensation will drip into and then out of the brew baskets. 1/4 cup discharging overnight is possible. Place an appropriate container under each brew basket when not in use.
7. We recommend leaving the power to the brewer on overnight. The water tank is well insulated and will use very little electricity to keep the tank hot. Leaving the brewer in the on position will also avoid delays at the beginning of shifts for the brewer to reach operating temperature.

Operating Procedures

1. Turn brewer on/off switch (E) to the on position

- The power switch will illuminate to indicate that the brewer has power and is operating.
- When the **ready light (F)** illuminates, the brewer is fully up to temperature. The amount of time required to gain full operating temperature will vary depending on the electrical configuration that was ordered, and the temperature of the incoming water.

2. Pre-heat the dispensers.

This step is very important to the overall success of the brewing operation. FETCO avoids the damaging affects of heat on fresh brewed coffee by using highly insulated dispensers. The dispenser must be pre-heated with hot water from the brewer. This preheating process ensures that the coffee in the first brew starts out hot. Significant heat loss will occur when brewing coffee into a cold dispenser. Preheating is not required for subsequent brews unless the dispenser remains empty for an extended period of time and has cooled down.

- Slide the empty brew basket(s) (D) into their rails and put the empty dispenser(s) in position under the basket for preheating. Select the half batch mode, (A) if you have this option.
- When the ready light illuminates, start a brew cycle by rotating the brew lever (B) to the brew position. This starts clean hot water flowing into the brew basket and then into the dispenser.
- Stop the cycle when each dispenser is approximately 1/2 full by moving the brew lever to the off position. This interrupts the brew cycle and resets the brewer .
- Let the dispensers stand 10-15 minutes, or until use, to allow the heat from the water to be absorbed by the dispensers.

3. Remove the brew baskets from the brewer when you are certain that the flow of hot water has stopped from the bottom of the basket.

- H model brewers will have a safety bar (C) in front of the brew basket to make removing the brew basket a 2-handed operation. This was done to help draw attention to the basket so the operator will notice any residual hot water or coffee.
- Place a paper filter in each basket to be used. Pour into the paper filter the appropriate amount of pre-measured, ground coffee. The amount of coffee used will depend on your personal tastes and the recommendation of your roaster.
- Slide the brew basket back into the rails on the brewer. Insure the latch is outside of the basket.

4. Carefully drain any coffee or preheating water from the dispensers through the faucets before starting a coffee brewing cycle.

- Overflowing of the dispensers may result if the dispensers are not completely empty when the brew cycle begins. Verify by opening the faucet over an appropriate container or drain. The last several cups cannot be seen in the sight gauge tube.
- **CAUTION:** both the coffee or water may still be hot enough to cause burns, so be careful when draining the dispensers

5. Place the thermal dispenser(s) in position under the brew baskets.

- Ensure that the brew funnel is in place, the dispenser is empty, the faucet is closed, and the vent cap on the sight gauge is open.
- The twist lock cover is for transporting the dispenser only. It must be removed before placing the dispenser under the brew basket.

6. Start the brew cycle in the same manner used to start the water used to preheat the dispensers.

- It will not be necessary to interrupt the cycle while brewing coffee. The brewer will return to the stopped and ready status automatically.
- It is normal for the ready light to go out after the start of the brew cycle. On twin brewers, there is enough hot water in the brewer to support a second brew, even if the ready light is off. After brewing on both sides, you must wait for the ready light to come back on.
- The electrical configuration and the electrical power connected to the brewer will determine how long before the ready light comes back on for the next brew.

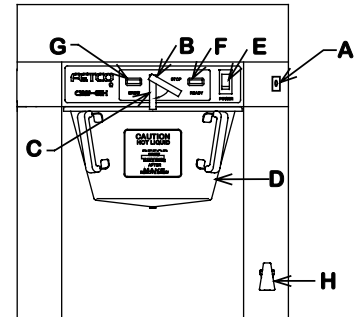

| Legend: | |
|---------|------------------------|
| A | Full/half batch switch |
| B | Brew lever |
| C | Safety bar |
| D | Brew basket |
| E | On/off switch |
| F | Ready light |
| G | Brew light |
| H | Hot water faucet |

CAUTION

- **Do not remove the brew basket immediately after the brew cycle has finished. Wait until dripping from the bottom of the brew basket has stopped. Carefully remove the brew basket while inspecting the inside of the basket for hot coffee that may have been trapped or has not finished draining.**

TPD- 3.0 LUXUS Dispensers:

The LUXUS dispensers are super insulated. A full LUXUS will typically lose only 4 degrees per hour if the dispenser is preheated first with hot water.

Closing a LUXUS dispenser for transportation or storage must be done in the following steps to avoid spraying hot liquid from the top of the sight gauge. Failure to follow these steps in order can cause a hydraulic reaction.

By moving the funnel vent cap down on the larger surface area of the main body an upward movement amplified many times is created in the sight gauge. This forces the liquid out of the top of the sight gauge vent.

1. Install the twist lock cover, ensuring that the safety lock engages.
2. Close the sight gauge vent plug.
3. Close the twist lock cover funnel vent cap.
4. Open the LUXUS by reversing the above order.
Open the funnel vent cap first, then the sight gauge vent cap.

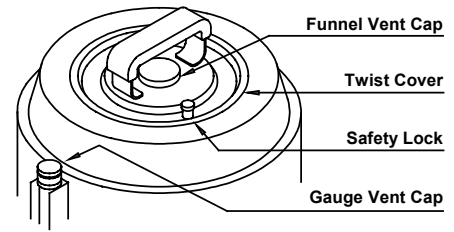

Because the faucet body is metal, it will dissipate the beverage temperature over time. This temperature loss is more noticeable with hot beverages than cold. If a dispenser of hot coffee goes unused, the first ounce or two will be cool and should be discarded. Subsequent cups will be hot.

Cleaning:

Use the same techniques and products as you would use to clean any coffee urn i.e.

- a) the sight gauge brush to scrub the gauge
- b) urn brush for inside the dispenser
- c) urn cleaner to clean the dispenser
- d) stainless steel polish for the outside
- e) hot water and towels for the faucet parts

Service

Warranty

All FETCO brewers come with a limited warranty. All warranty service must be authorized by calling the FETCO Service Department at (800) 338-2699.

Principles of Operation

Fill System

The fill system consists of a liquid level control board, a water level probe at the top of the tank, a fill valve, and a fill tube. As the water rises and touches the probe, continuity is established between the probe tip and the tank body, and the fill valve closes.

When water is dispensed, the water level drops below the probe. After a 5 second delay, the fill valve opens until the water touches the probe again.

The 5 second delay, and the speed that water refills the tank during brewing, results in many short bursts of water. The sound made by these repetitive bursts will let you know the fill system is functioning normally.

The fill system is designed to protect the heaters during both the installation and a loss of the water supply. During initial installation, or whenever the power switch is turned on, voltage will not be supplied to the thermostat until the tank fills and water touches the water level probe.

During operation, when water is dispensed and the water level drops below the probe, a fill signal is sent to the fill valve. If the probe does not sense water after 40 seconds, the voltage to the thermostat and the heaters is removed.

Water enters the tank through the fill tube. A hole is drilled in the upper portion of the fill tube to prevent water from being siphoned from the tank. The fill tube extends to the bottom area of the tank. This introduces cold incoming water directly to the heaters and away from the dispense assembly.

The water tank can be drained through a valve located inside the lower compartment of the brewer.

Temperature System:

The temperature system consists of an electronic thermostat, a temperature probe, and heating elements, and is enabled by the liquid level control board. (See the previous section - Fill Circuit.)

When the water level probe is in contact with water, power is delivered to the thermostat through the liquid level control board. If the temperature probe senses that the water is not hot enough, the thermostat energizes the heating elements through the solid state relay (SSR), the water is heated, and the ready light goes off.

Once the water temperature reaches the set point, the thermostat disengages power to the heaters and the ready light illuminates.

The thermostat is adjusted to 205° F ± 2° at the factory. (Slightly lower for high altitude installations.)

Timing System:

The timing system consist of the timer and the dispense latch assembly.

When the brew handle is rotated from the stop to the brew position, it pushes the plunger in the latch coil and closes the micro switch, and the timer starts the timed cycle. It also starts the hot water flowing.

The timer energizes the dispense latch coil, which acts as a magnet, to hold the brew handle in the brew position. It also lights the brew light. The coil remains energized throughout the brew cycle timed sequence.

When the timer finishes its cycle, it removes voltage from the latch coil. The latch coil then releases the brew handle, a spring returns it to the stop position, and the flow of water stops. This return opens the micro switch, stopping voltage from going to the timer. The brew light and the timer are disabled, and wait for the brew handle to engage the next brew cycle.

Dispense System:

The dispense system is completely mechanical. It is one of the areas that makes FETCO's brewer truly unique. (See the illustration in this section.)

When you rotate the brew lever down to brew, the end of the dispense tube is submerged in the hot water tank. It is held in the brew position by the magnetic action of the dispense latch coil.

The brew water travels down the dispense tube to the sprayhead assembly. The flow disc above the spray cutter controls the rate of flow over the coffee. The standard hole in the flow disc is .281". Other flow discs are available for special situations like high levels of by-pass.

The sprayhead can be assembled incorrectly during cleaning. Refer to the cleaning label on the brewer for proper assembly. The flow disc has the flange down, flat side up. The six-triangle spray cutter has the flange up. The eight-hole spray cutter used in place of the triangle cutter goes bumps down.

A bypass valve and tube are connected to the sprayhead. This valve directs brew water around the outside edge of the filter paper. The by-pass valve is shipped in the closed position from the factory. Each time the valve is adjusted, the brew volume is affected. Adjustment of the by-pass valve is for flavor only.

When the timer circuit releases the brew latch, the dispense tube pops back above the hot water level. The remaining brew water drains from the dispense system leaving it free of standing water. Steam escaping from the brew tank through this tube inhibits the formation of lime in the brew system.

The dispense system is clean & semi dry for all but the brief time required for the brew cycle. This eliminates any chance of lime build-up affecting the brew cycle.

It is very easy to dislodge the dispense tube seals while servicing the dispense system. If you see it leaking profusely, remove the nut and dispense tube. Reset the seal fully into the recess and carefully insert the dispense tube. Then secure the locknut before you back the tube into position. (See detailed instructions on page 10.)

Mechanical Illustration - Dispense System

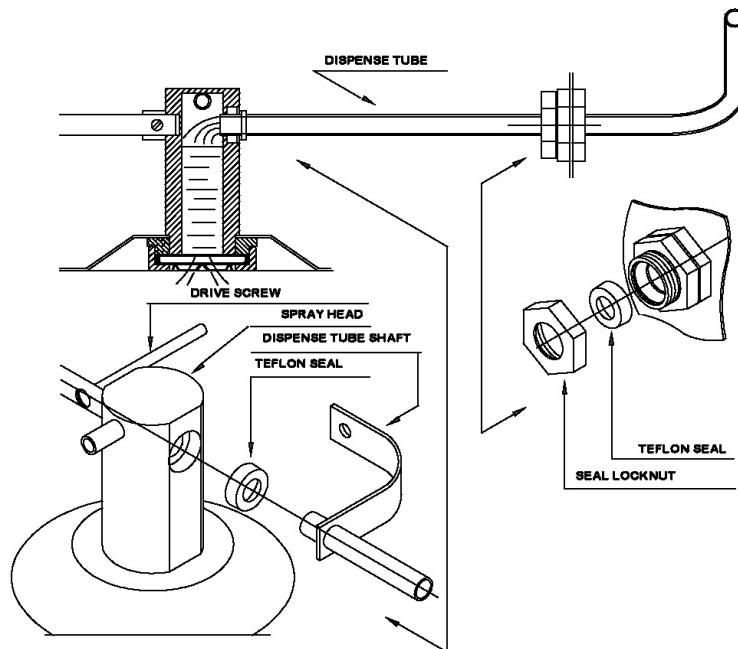
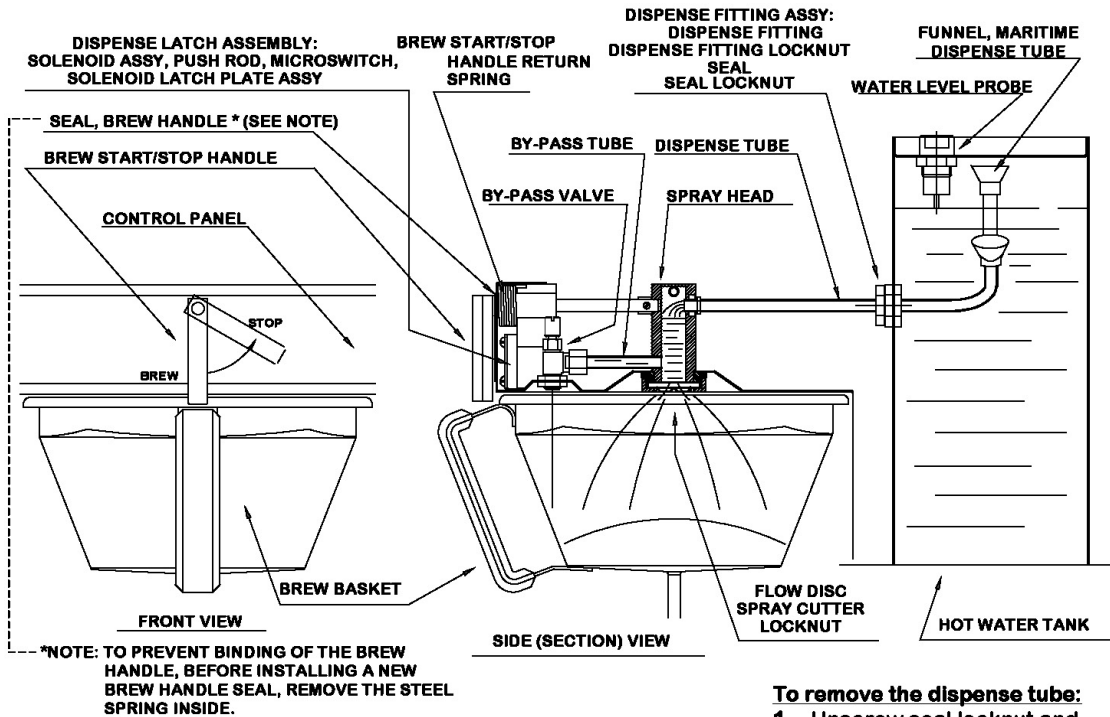

To remove the dispense tube:

1. Unscrew seal locknut and release the drive screw from dispense tube shaft.
2. Turn the dispense tube slightly back and forth, while pushing the tube into the hot water tank until it is free from the sprayhead.

Pull the dispense tube out of the tank. Remember the tube is bent inside the tank. The seal will come out with the tube.

To install the dispense tube:

1. Clean any lime build up off the tube and then slide the seal off. Push the seal carefully into its chamber in the fitting. (spring towards the hot water tank.)
2. Place the seal locknut onto the tube and slide the tube into the seal. Tighten the seal locknut.
3. Work the tube back into the sprayhead seal.
4. Join the dispense tube shaft and the brew handle shaft with the drive screw.

Adjustments

Thermostat Adjustment:

During normal operation, the digital readout displays the last two digits of the actual water temperature. When the adjustment tool is turned, the readout begins flashing to indicate the set point, not the actual temperature. After the tool is released, the readout stops flashing and displays the actual temperature again.

A red LED lights when the power to the thermostat is on. A yellow LED lights when the thermostat is calling for heat.

To adjust, turn the adjustment tool. If no adjustment tool is present, a small flat-head screwdriver may be used. The display will flash, indicating that the display is showing the set point, not the actual temperature.

The default temperature scale is Fahrenheit. When set to Fahrenheit, the display shows only the last 2 digits of the temperature.

Examples:

7 5 = 75°F

8 7. = 187°F

0. 3. = 203°F

The dots below the numbers indicate the temp range.

0 dots – less than 100° F

1 dot – between 100° and 200° F

2 dots – over 200° F

Timer Adjustment:

The timer has two independent settings, with three dials for each setting. The first dial in each group sets 100 second increments, the second dial sets 10 second increments, and the third dial sets 1 second increments.

A red LED lights when the power to the timer is on. A yellow LED lights when the timer is running.

A small flat head screwdriver is required to adjust the dials.

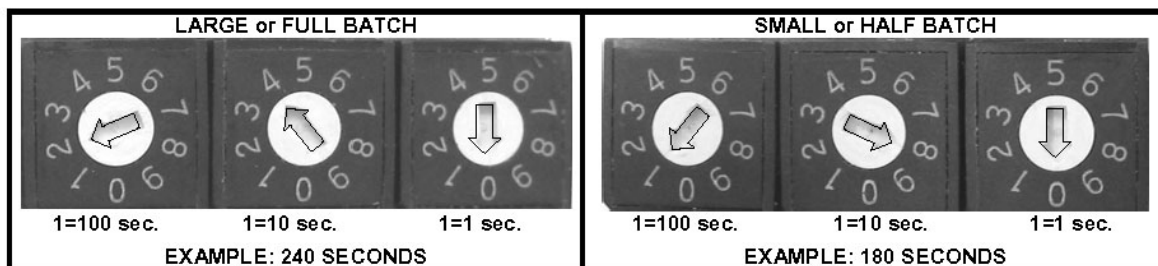

part # K034, digital timer, 100-120 VAC

part # K036, digital timer, 200-240 VAC (export versions only)

Water Level Control Board

The board features a jumper to adjust its' sensitivity to reverse osmosis or other types of ultra-pure water.

The default jumper setting is LO for normal water. If the brewer tank overfills because of ultra-pure water, the jumper should be set to HI.

A red LED lights when the power to the board is on.

A green LED lights when the water level probe detects that the tank is full.

A yellow LED lights when the FILL circuit is energized.

A second yellow LED lights when the HEAT circuit is energized.

Bypass Adjustment:

The purpose of the bypass valve is to allow a portion of the brewing water to flow between the brew basket and the wire insert, directly into the server, without coming in contact with the coffee grounds. The bypass can be adjusted from 0% to 33% of the total brewing water. Unless requested at the time of order, all brewers are shipped with the bypass valves closed (0%). Adjusting the bypass always changes the total brew volume, so the timer setting must always be checked and adjusted.

To adjust the bypass:

- Remove the brewer's upper cover.
- The bypass valve is located above the brew basket, to the right and to the front.
- Remove the brew basket.
- Place a container under the spray head and a separate container under the bypass hole.
- Turn the bypass valve clockwise to decrease, and counter-clockwise to increase the bypass amount. A good starting point would be one full turn for each 5% change.
- Brew a full cycle and measure the amount of water in both containers.
- The ratio of the bypass water to the total in both containers is the bypass percentage.
Example: $\frac{1}{2}$ gal. bypass + 2.5 gal. from spray head = 3 gal. total. Bypass = 16.66%.
- Several adjustments may be necessary until the desired results are achieved.

Wiring Diagram

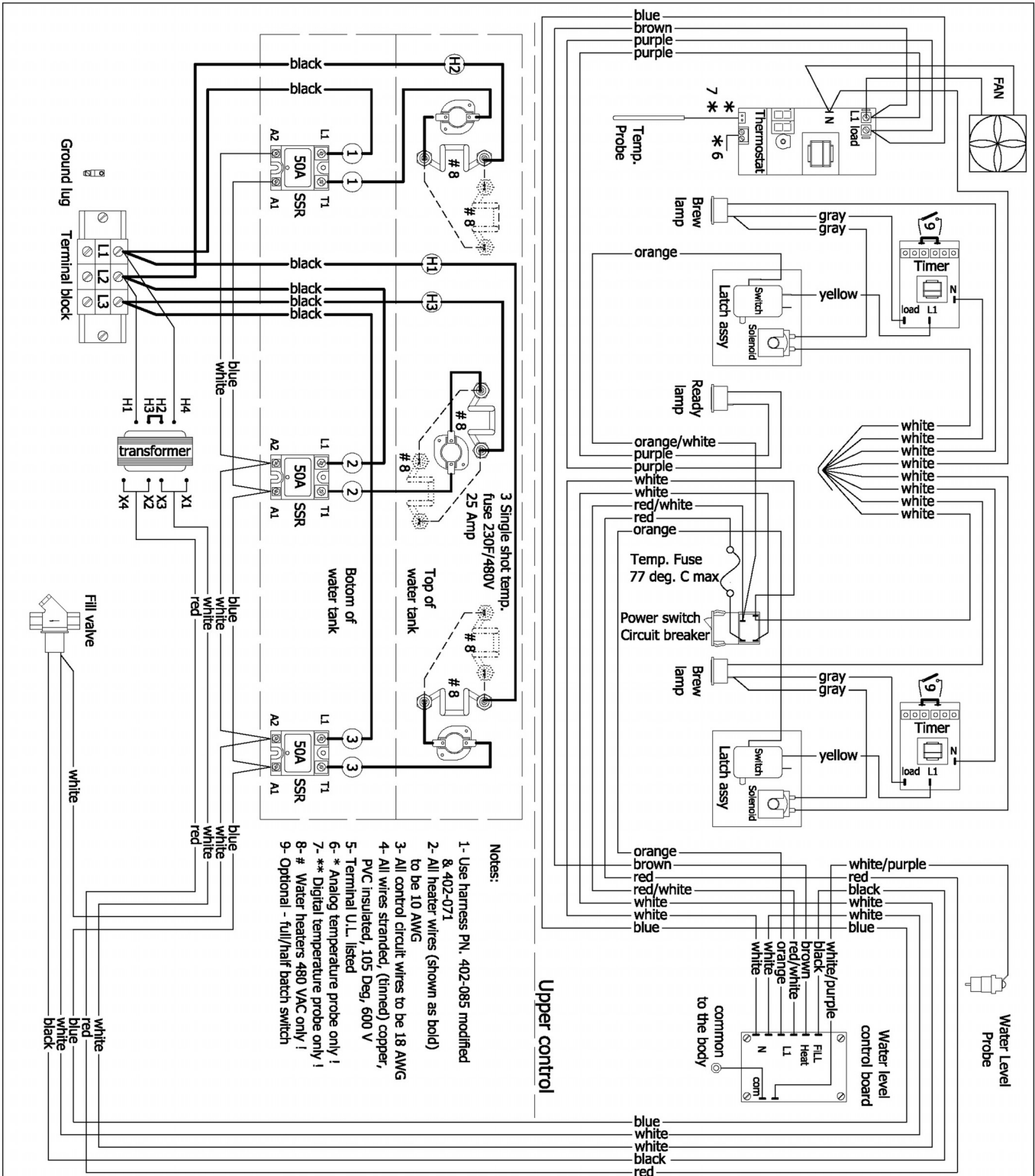

FETCO FOOD EQUIPMENT TECHNOLOGY COMPANY
 600 ROSE RD.
 LAKE ZURICH, IL 60047
 PHONE: 847-719-3000, FAX: 847-719-3001
 WWW.FETCO.COM

FETCO PRODUCT NO.
CBS - 62 H

WIRING DIAGRAM CBS-62H SSR, L1,L2,L3+GRND, STEP DOWN TRANSFORMER 480/120VAC, 3 or 6 HEATERS, W/FAN

WIRING DIAGRAM NO.
401350-001

Dispenser Parts

LUXUS® TPD- 3.0

| Reference Number | Part Number | Description |
|------------------|-------------|--|
| 1 | 71026 | faucet, complete, black handle (ES) |
| 1 | 71037 | faucet upper assy. w/black handle (handle, spring, seat cup and nut) |
| 1 | 71035 | faucet seat cup |
| 1 | 71028 | faucet handle- black |
| 1 | 71027 | faucet handle, decaf faucet (orange) |
| 2 | 31045 | faucet union nut |
| 3 | 71036 | faucet "c" ring |
| 4 | 102052 | faucet shank assembly |
| 5 | 24009 | faucet shank "o" ring 1/2" x 3/4" |
| 6 | 12018 | vent top plug |
| 7 | 71017 | sight gauge washer lower |
| 8 | 71024 | sight gauge cap |
| 9 | 71018 | sight gauge washer upper |
| 6-9 | 102020 | sight gauge cap and vent assy. |
| 10 | 21035 | sight gauge tube 12-1/2" (plastic) |
| 10 | 71033 | sight gauge tube 12-1/2" (glass) |
| 11 | 82015 | faucet shank screw-2 required |
| 12 | 101038 | twist lock cover assembly |
| 13 | 101051 | brew funnel assembly |
| 15 | 41011 | LUXUS label |

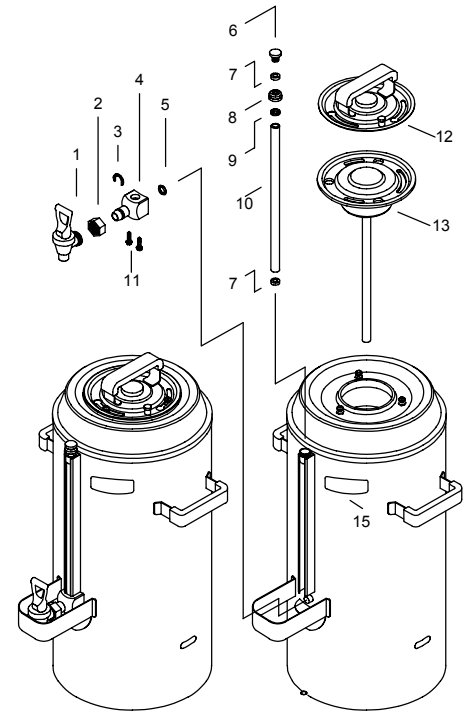

Brewer Parts

Figure 1 – CBS-62H Main Assembly

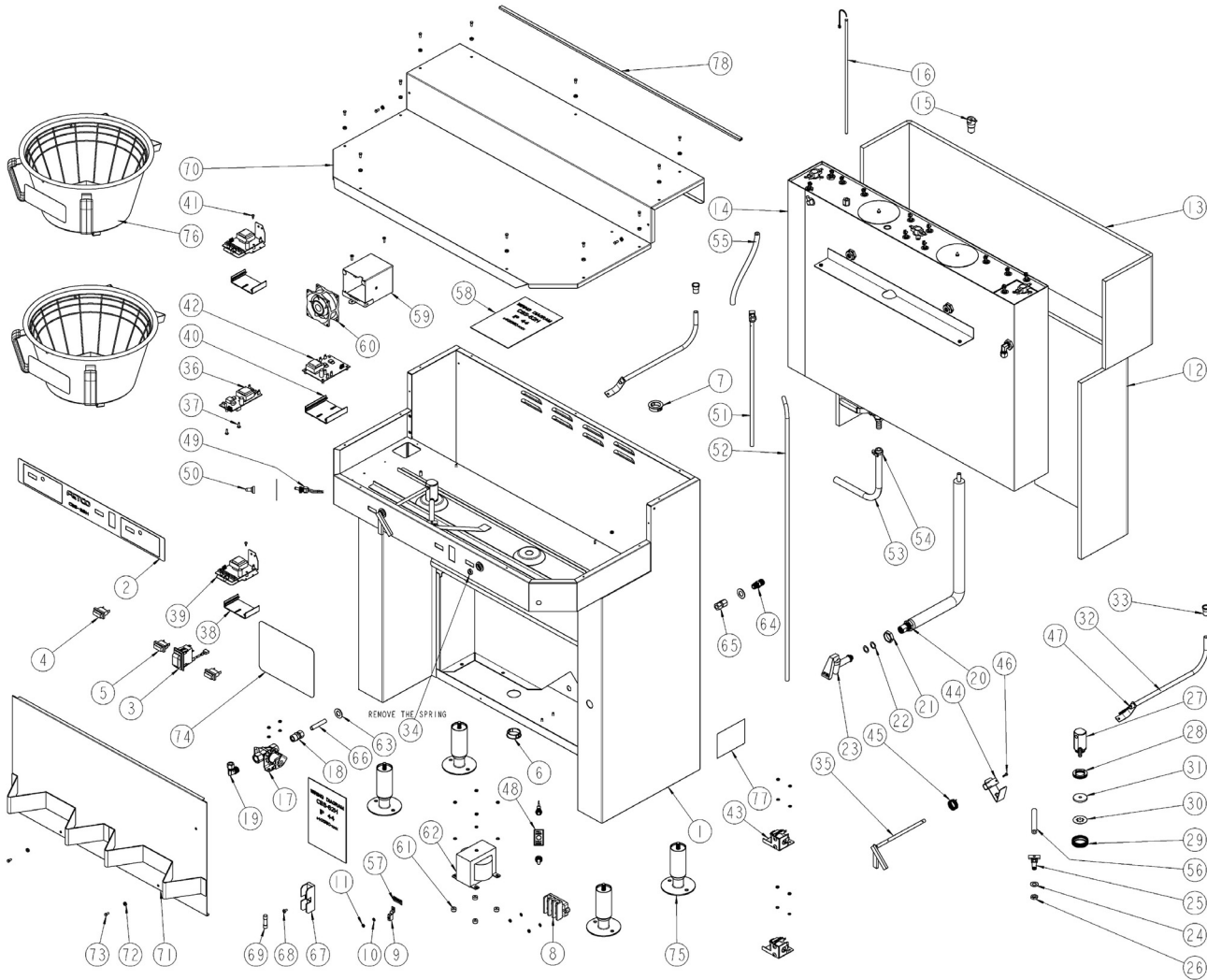

| ITEM # | QTY | PART # | DESCRIPTION |
|--------|-----|--------|---|
| 1 | 1 | 002411 | WELDMENT, CBS-62 H IP44 VERSION |
| 2 | 1 | 45028 | OVERLAY CBS-62 H |
| 3 | 1 | 102368 | ASSEMBLY, POWER SWITCH, MARITIME VERSION |
| 4 | 2 | 102370 | ASSEMBLY LAMP, "BREW" INDICATOR, 120VAC, WITH SQUARE CORNERS |
| 5 | 1 | 102369 | ASSEMBLY LAMP, "READY" INDICATOR, 120VAC, WITH SQUARE CORNERS |
| 6 | 1 | 86018 | PLUG, DOME, 1.375 MOUNTING HOLE |
| 7 | 1 | 86021 | BUSHING, SNAP, 1.375 MTG HOLE |
| 8 | 1 | 52090 | TERMINAL BLOCK, 3 POLE, W/ MARKING STRIP |
| 9 | 1 | 65002 | CONNECTOR, COPPER LUG |
| 10 | 19 | 83026 | WASHER, INTERNAL TOOTH LOCK, #8 SCREW SIZE |
| 11 | 19 | 84002 | NUT, HEX, #8-32 MACHINE SCREW |
| 12 | 1 | 22098 | INSULATION, TANK LOWER PART, CBS-62 H |
| 13 | 1 | 22097 | INSULATION, TANK UPPER PART, CBS-62 H |
| 14 | 1 | 104155 | ASSEMBLY, TANK CBS-62H, IP-44, 3 X 4000W, 480VAC (SEE FIG. 2) |
| | | 104100 | ASSEMBLY, TANK CBS-62H, IP-44, 6 X 4000W, 480VAC (SEE FIG. 2) |
| 15 | 1 | 102381 | ASSEMBLY, WATER LEVEL PROBE, TEFLON, 1.75" LG. X 0.25" DIA |
| 16 | 1 | K065 | ASSEMBLY, DIGITAL TEMP. PROBE, 14.0" LG W/34" CABLE |
| 17 | 1 | 102323 | VALVE, S-45 120VAC |
| 18 | 1 | 31028 | FITTING, COMPR. MALE CONNECTOR 3/8 TUBE OD X 3/8 MPT |
| 19 | 1 | 31055 | FITTING, FILL VALVE INLET |
| 20 | 1 | 102017 | ASSEMBLY, HOT WATER SPOUT |

| | | | |
|----|----|--------|---|
| 21 | 1 | 13022 | LOCKNUT, FAUCET SMALL |
| 22 | 2 | 83047 | WASHER, FIBER, ID 0.5 X 0.75 OD |
| 23 | 1 | 71021 | FAUCET HPSC-BR-8 REGULAR HANDLE (COMPLETE FAUCET) |
| | 1 | 71039 | FAUCET, UPPER ASSY. (SUBCOMPONENT OF #23) |
| | 1 | 71003 | FAUCET SEAT CUP (SUBCOMPONENT OF #23) |
| 24 | 2 | 83041 | WASHER, .812"OD X .412"ID, FLAT |
| 25 | 2 | 102028 | ASSEMBLY, BYPASS, CBS-60'S, 50'S |
| 26 | 2 | 31116 | LOCKNUT 1/8"-27 NPT |
| 27 | 2 | 102267 | ASSEMBLY, SPRAY HEAD, CBS-60'S |
| 28 | 2 | 33002 | LOCKNUT, SPRAY HEAD |
| 29 | 2 | 31015 | LOCKNUT, SPRAY CUTTER |
| 30 | 2 | 05014 | SPRAY CUTTER |
| 31 | 2 | 05016 | DISK, FLOW, SPRAY CUTTER, .281 DIA |
| 32 | 2 | 002011 | WELDMENT, DISPENSE TUBE, CBS-60'S |
| 33 | 2 | 23199 | FUNNEL, MARITIME DISPENSE TUBE |
| 34 | 2 | 24006 | SEAL, DISPENSE TUBE, 5/16"DIA |
| 35 | 2 | 102366 | ASSEMBLY, HANDLE, DISPENSE, CBS-50H, -60H, MARITIME VERSION |
| 36 | 1 | K033 | ASSEMBLY, BOARD THERMOSTAT DIGITAL/ANALOG 100-120VAC |
| 37 | 4 | 82053 | SCREW, # 6-32 X 1/2" TRUSS HD PH |
| 38 | 2 | 002244 | WELDMENT, TIMER PLASTIC TRACK, CBS-60'S, 2"LG |
| 39 | 2 | K034 | ASSEMBLY, DIGITAL TIMER 100-120VAC |
| 40 | 1 | 002245 | WELDMENT, CONTROL BOARD PLASTIC TRACK, CBS-60'S, 3"LG. |
| 41 | 2 | 82130 | SCREW, #6 X 3/8" LG, SHEET METAL, ROUND HEAD PHIL. |
| 42 | 1 | 108046 | ASSEMBLY, BOARD, WATER LEVEL CONTROL, 200KOHMS, 100-120VAC |
| 43 | 2 | 102008 | ASSEMBLY, DISPENSE SOLENOID LATCH |
| 44 | 2 | 102269 | ASSEMBLY, DISPENSE LATCH, CBS-60'S |
| 45 | 2 | 85004 | SPRING, BREW HANDLE RETURN |
| 46 | 2 | 82004 | SCREW, 6-32 X 5/8" RND HEAD PHILLIPS |
| 47 | 2 | 82018 | SCREW, 8-32 X 2-1/4" LG |
| 48 | 2 | 46010 | LABEL, FULL/HALF BREW |
| 49 | 2 | 102359 | SWITCH, FULL/HALF, TOGGLE |
| 50 | 2 | 52091 | BOOT, PROTECTIVE, HALF/FULL SWITCH, IP44 |
| 51 | 1 | 002035 | WELDMENT, COLD WATER TUBE INLET, CBS-60'S |
| 52 | 1 | 32035 | TUBE, FILL VALVE - TANK WATER INLET |
| 53 | 1 | 25046 | TUBE, 5/8"OD X 3/8"ID X 15"LG, DRAIN |
| 54 | 1 | 86038 | CLAMP, HOSE, .670"-.780" DIA RANGE |
| 55 | 1 | 25002 | TUBE, 1/2 OD X 1/4 ID X 9.00 LG, VENT, CBS-60's H |
| 56 | 2 | 25112 | TUBE, 1/2 OD X 1/4 ID X 4.00 LG BREW, CBS-60's H |
| 57 | 1 | 44004 | LABEL GROUND |
| 58 | 2 | 401350 | WIRING DIAGRAM,CBS-62 H, IP44 VERSION |
| 59 | 1 | 002414 | WELDMENT, BOX, FAN COVER, CBS-62H, IP44 VERSION |
| 60 | 1 | 56029 | FAN, COOLING,120VAC, 8W, 3.15"SQ x 1.5" HEIGHT |
| 61 | 4 | 29021 | SPACER, #8 SCREW SIZE, 1/2" OD X 1/4" LG, ROUND UNTH. |
| 62 | 1 | 52087 | TRANSFORMER STEP DOWN, 150VA |
| 63 | 2 | 83008 | WASHER, 1.062"OD x .562"ID x .063 THICK |
| 64 | 1 | 31191 | FITTING, FLARED 45 DEG, STRAIGHT, 3/8 TUBE x 1/4 NPTF MALE, BRASS |
| 65 | 1 | 31023 | FITTING, COMPR., CONNECTOR, 3/8 TUBE OD X 1/4 FPT |
| 66 | 1 | 32087 | TUBE, COLD WATER, 3/8"OD X 2.0"LG, CBS-62H, IP44 |
| 67 | 1 | 52092 | FUSE BLOCK, 15 Amp, 600VAC |
| 68 | 1 | 82059 | SCREW, #8-32 X 3/8 TRUSS HD PHIL., MACHINE |
| 69 | 1 | 52096 | FUSE, TIME DELAY, 2 A, 13/32" X 1 5/16" |
| 70 | 1 | 002434 | WELDMENT, COVER, TOP, CBS-62H, IP44 |
| 71 | 1 | 002417 | WELDMENT, COVER FRONT, LOWER, CBS-62 H, IP44 VERSION |
| 72 | 15 | 83076 | WASHER,#8 SCREW SIZE, CUSHION AND SEALING |
| 73 | 15 | 82160 | SCREW, # 8-32 x 3/8" LG., HEX HEAD, 18-8 SS |
| 74 | 1 | 46013 | LABEL, CLEANING INSTRUCTIONS |
| 75 | 4 | 102372 | ASSEMBLY, IP44 LEG, 3.250 LG. TUBE, SS |
| 76 | 1 | 101050 | ASSEMBLY, BREW BASKET, CBS-60'S |
| | 1 | 09005 | WIRE INSERT, 21 X 7 (SUBCOMPONENT OF #76) |
| | 1 | 09009 | WIRE INSERT ,18 X 7-1/2" (HALF-BATCH) (SUBCOMPONENT OF #76) |
| 77 | 1 | 42005 | LABEL, 4" X 3" SERIAL NUMBER |
| 78 | 1 | 24108 | EDGE PROTECTOR, BLACK, 35" LG, (CUT FROM 97108) |

**Figure 2 – CBS-62H – Tank Assembly, Part # 104155 (3 X 4000W heaters)
Part # 104100 (6 X 4000W heaters)**

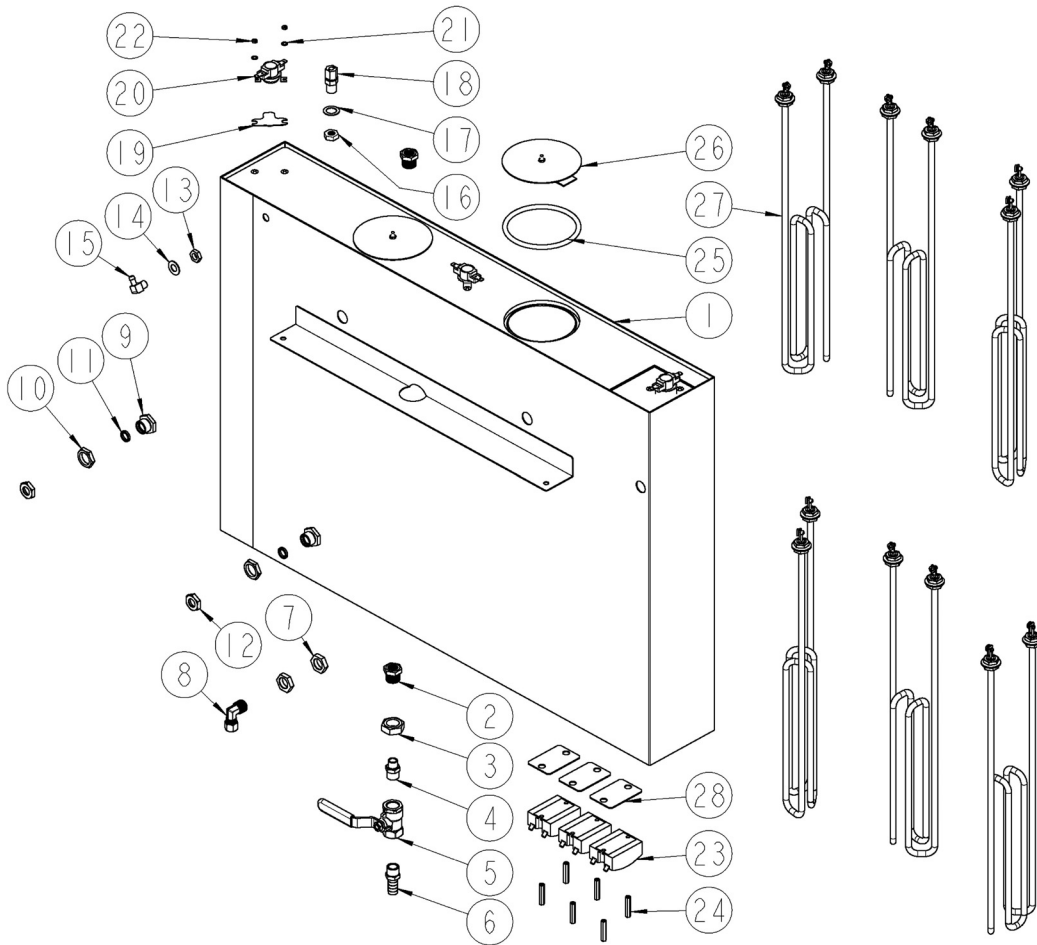

| ITEM # | QTY | PART # | DESCRIPTION |
|--------|--------|--------|---|
| 1 | 1 | 004075 | WELDMENT, TANK CBS-62 H, SSR |
| 2 | 2 | 31021 | BUSHING, 3/4-16 X 1/4 NPSM, HEX HEAD |
| 3 | 1 | 84007 | NUT, 3/4-16 HEX JAM |
| 4 | 1 | 31082 | FITTING, HEX NIPPLE, 3/8 MPT X 1/4 MPT |
| 5 | 1 | 34004 | VALVE, BALL 3/8 FPT X 3/8 FPT |
| 6 | 1 | 31054 | FITTING, 1/2 HOSE ID X 3/8 MPT |
| 7 | 2 | 31118 | LOCKNUT 3/8"-18 NPT |
| 8 | 1 | 31055 | FITTING, FILL VALVE INLET |
| 9 | 2 | 33006 | FITTING, TANK, (7/16 DIA DISPENSE TUBE) |
| 10 | 2 | 33007 | LOCKNUT, 7/16 STRAIGHT PIPE THREAD |
| 11 | 2 | 24008 | SEAL, DISPENSE TUBE, 7/16"DIA |
| 12 | 2 | 31052 | LOCKNUT, 7/16", DISPENSE TUBE SEAL, KEEPER |
| 13 | 1 | 31116 | LOCKNUT 1/8"-27 NPT |
| 14 | 1 | 83041 | WASHER, .812"OD X .412"ID, FLAT |
| 15 | 1 | 31005 | FITTING, 90 DEG. ELBOW, 1/4 HOSE ID X 1/8 MPT |
| 16 | 1 | 23249 | LOCKNUT 1/4"-18 NPT MODIFIED THREAD |
| 17 | 1 | 83042 | WASHER, .875"OD X .562"ID, FLAT |
| 18 | 1 | 25098 | FITTING, COMPRESSION MALE CONNECTOR |
| 19 | 3 | 03332 | BRACKET 2, ONE SHOT THERMOSTAT |
| 20 | 3 | 53087 | THERMOSTAT, SINGLE SHOT, 480V/25A |
| 21 | 6 | 83011 | WASHER, #6 SCREW SIZE, INTERNAL |
| 22 | 6 | 84045 | NUT, HEX 6-32, UNDERSIZED |
| 23 | 3 | 108071 | ASSEMBLY, RELAY, SOLID STATE, 50 A/ 600V |
| 24 | 6 | 15013 | STANDOFF, 6-32 x1.25 LG., 1/4 HEX WIDTH |
| 25 | 2 | 24002 | O-RING, TANK COVER |
| 26 | 2 | 102013 | ASSEMBLY, TANK COVER |
| 27 | 3 or 6 | 107030 | ASSEMBLY, IMMERSION HEATER, 4000W, 480VAC |
| 28 | 3 | 03443 | ALUMINUM BRACKET FOR SSR |

Troubleshooting

| Brewing Problem | Possible Cause | Solution |
|---|---|---|
| Brew handle will not stay down | Power switch off. | -Turn switch on. |
| | No power to the brewer (Brewer lights are not illuminated) | -Make sure the brewer is plugged in. -Check the wall circuit breaker / reset -Turn the brewer power switch off then back on (it has an internal breaker) |
| | Bad timer or dispense latch assembly. (Brew light does not come on and handle won't stay down) | -Check for voltage reaching the timer from the dispense latch assembly if yes replace timer. If no, replace latch assy. |
| | Bad dispense latch assy. (Brew light does come on and handle won't stay down) | -Replace the dispense latch assembly |
| | Bad dispense latch assembly (brewer buzzes when in brew cycle) | -Replace the dispense latch assembly |
| Brew handle stays down but no water is dispensed | No water reaching the brewer | -Make sure the shut off valve is open. -Check water line for kinks; replace line if necessary -Check to see if filter is clogged by changing it. |
| Short brew levels EVERY BREW (One or Both sides are affected and levels are consistent) | Flow discs in spray heads in upside down | -Reassemble spray heads - bumps on spray cutter face ↓ with flange on flow disc facing ↓ |
| | Water filter clogged | (See details in next section) |
| | Spray head clogged | -Clean and or replace the sprayhead |
| | Timer/s are set too low | -Advance timers to proper level. |
| | Incoming Voltage is too low for timers to function at proper time sequences | -Reset wall circuit breaker as one side may drop out & not flag the breaker. -Call an electrician to find loose connections in the building |
| Short brew levels SOME BREWS (One or Both sides are affected and levels are erratic) | Water filter clogged. (problem is worse during simultaneous brews) | -Replace water filter |
| | Weak dispense latch assembly (usually buzzes during cycle) | -Replace dispense latch assembly. |
| | Water pressure or flow rate is too low or fluctuates too much to support a full brew. (problem is worse in simultaneous brews) | -Make sure brewer has a dedicated water line -Ensure that the shut off valve is open all the way (Never use needle saddle valves) -Increase the diameter of the water line to the brewer and or find stable source. |
| Brew Time required to fill LUXUS are not the same for both sides | Brewer is not level | -With an accurate level, level the brewer front to back and left to right by adjusting the feet. |
| High brew levels EVERY BREW (overfills but does stop) SOME BREWS | Timer/s are set too high | -Adjust timers down to appropriate level |
| | Thermal server not empty | -Empty the server and try again |
| Brew basket or filter overflows | | -Call FETCO Service Dept. to discuss. (800) 338-2699 |
| Weak Coffee | Spray head missing | -Attach spray head assembly. |
| | Improper dose | -Measure and confirm correct dose |
| | Filter papers | -Make sure only one paper is used |
| | Cracked dispense tube | -See "spray head drips MAJOR", below |
| | Low brew temperature (Temperature inside the hot water tank is set to 205° F, the metal delivery system drops the temp.) | -Adjust thermostat so the water stream measured at the bottom of the brew basket, 1/3 of the way through the brew cycle, equals 190 degrees + or - 5 degrees |
| Grounds not saturated | Spray head missing | -Replace spray head |
| | Half batch used incorrectly | -Use smaller "half batch" brew basket -Discourage half batch use -Investigate the need for a smaller brewer |
| | Water Softener in use | -Move brewer water feed to a non-softened source. |
| | Degassing - extremely fresh coffee | -Call FETCO Service Dept. to discuss. (800) 338-2699 |
| No bypass EVERY BREW → SOME BREWS → | Bypass valve closed | -Open bypass valve |
| | Flow disc wrong size or missing | -Correct or replace flow disc |
| Spray head / brew basket drips either side or both MINOR | Condensation around the sprayhead area | -Wipe sprayhead area after brewing; place an empty container under brew cone when not in use. |
| | Condensation from water tank dripping through dispense tube | -Insert an empty brew basket and server under brew heads when not in use |

| Brewing Problem | Possible Cause | Solution |
|--|--|--|
| Spray head / brew basket drips either side or both MAJOR | Cracked dispense tube/s (This problem starts out minor but gets steadily worse) | -Replace both dispense tubes even if other side is not dripping |
| | Fill valve not sealing (Will drip even with power off.) | -See next section - "Brewer won't stop brewing", "Bad or stuck fill valve". |
| Brewer won't stop brewing (not same as high brew levels) | Dispense tube cracked | -See "sprayhead drips MAJOR" above |
| | Mechanical binding (brew handle stays down / brew light turns off at normal time) | -Re-align the brew handle / brass sprayhead tower / and dispense tube into a straight line by moving brass tower |
| | Water pressure over 75psi | -Place a water pressure regulator on the line and reduce to 20-75 psi |
| | Dispense tube drive screw off. A 2.5" screw that connects the handle to the dispense tube at the brass sprayhead tower. (handle returns up and brew lamp turns off but brewing continues) | -Ensure that the drive screw is straight (can be straightened by hand while still in the brew handle) and reconnect to the dispense tube. The flange that the drive screw engages MUST be held flat against the brass sprayhead tower, without being able to back out. |
| | Water level probe bad or encrusted with lime. (causes brewer to continue filling hot water tank which will overflow into the brew baskets) | -Clean lime build up on the probe tip and/or tank wall. (Holding the probe wire (green) from the probe end to the body of the brewer should stop the fill if the probe is bad but the liquid level board is good) |
| | Bad liquid level control board | -Replace the LLC board if grounding the probe end of the (green) probe wire to the body of brewer does not remove the voltage at the fill terminal on the LLC board. |
| | Bad or stuck fill valve | -Rebuild or replace the fill valve if no voltage is on the coil (it is not magnetic) and it still passes water to the tank. (Disconnect the outlet side to see if it leaks water to the tank) |
| Coffee tastes too strong | Incorrect dosage | -Measure and confirm the correct amount of coffee required |
| | Short brew levels | -See "Short brew levels", above. |

| Temperature Problem (brewer only) | Possible Cause | Solution |
|---|--|---|
| See also LUXUS problems | | |
| Brew water is cold / not hot enough, ready light is OFF. (Before proceeding, make sure water tank refills when water is dispensed. The brewer will not heat unless the tank is full.) | No power to brewer. | -Make sure power switch is on. -Reset machine circuit breaker. -Check power connection. (plug or hard wire connection). -Check building circuit breaker. (Always reset breaker by switching off, then on.) |
| | Defective liquid level control board. (No power to thermostat). | -With power on, and water tank full, check LLC board for 120 volts on brown wire and neutral. Replace LLC board if there is no voltage. |
| | Bad connections on solid state relay. (No power to heaters). | -Check relay for burned or loose connections. Replace with high temperature connectors if necessary. |
| | Defective solid state relay. (No power to heaters). | -Check input and output voltages on relay. 120 volts on blue wire (input) but no voltage out to heaters indicates a bad relay. |
| | Bad heating element/s. | -Check amperage draw on heater wires. 0 amps = bad heater. |
| Brew water is cold / not hot enough, ready light is ON. | Bad Thermostat (the thermostat believes that it is at set temperature) | -Replace the thermostat and or thermal probe. It's not possible to trouble shoot the probe. |
| | Low brew temperature setting on thermostat | -See "Low brew temperature" under "Weak Coffee" section. |
| Slow to recover temperature (Ready light takes along time to come back on after brewing.) | Brewers with more than one heater can have just one fail | -Check amperage draw on heater wires. 0 amps = bad heater. |
| | Hot water tank limed up | -Remove access cover to the hot water tank and inspect for lime. Remove the brewer for shop de-liming if build up is thick. |
| Boiling | Thermostat set too high for altitude (Denver etc.) | -Reduce temperature setting to 3 degrees below boiling at your altitude |
| | Defective thermostat | -Replace the thermostat and or thermal probe. It's not possible to trouble shoot the probe. |

| LUXUS TPD-1.5 Problem | Possible Cause | Solution |
|---------------------------------------|---|--|
| LUXUS leaking from the base | Overflow of coffee, or water from cleaning running down the side and collecting in the black plastic base (1.5 gallon LUXUS only) | -Remove the plastic base (it slips on and off) wipe the interior and plastic base dry and reassemble. Monitor brew practices & do not clean containers in sinks or dishwashers |
| | Bad O-ring gasket behind faucet shank (1.5 & 3 gallon LUXUS) | -Remove the faucet, then unbolt the faucet shank from the LUXUS and replace the O-ring. |
| LUXUS leaking from sight gauge | Brew level set too high | -Adjust timers for proper level |
| | Sight gauge cap not tight | -Tighten gauge cap (show operators how this could have been loosened when the vent cap was opened) |
| | Lower gasket missing or bad | -Replace and or discourage casual cleaning practices |
| Coffee not hot enough | LUXUS not preheated before first brew of the day | -Preheat the LUXUS 1/2 full with hot water and let stand for 15 minutes |
| | Attempting to hold coffee too long. | -Review discard times |
| | Using 1/2 batch on regular basis | -Encourage full batch use except at end of day or shift. Explore the need for smaller brewers |
| | Judging temperature from a sample that is too small, taken from an infrequently used LUXUS | -A small amount of coffee in the faucet body will cool in about 15 minutes. |
| Drip from faucet | Blockage in faucet (hair from cleaning brush, coffee oils, etc.) | -Remove faucet bonnet (top part with handle attached) and clean seat cup and faucet body. Clean on regular basis |
| | Faucet seat cup | -Remove faucet bonnet (top part with handle attached) and replace seat cup. Stained cups are OK cracked or brittle are not. |
| Coffee won't dispense | Vents closed on top of gauge tube and or twist lock cover | -Open vents (vents are closed only for transporting the servers or to extend holding times prior to serving coffee) |

