

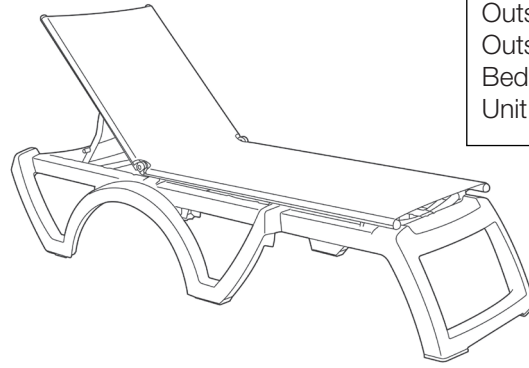

View Product

Outside Length: 73.5"
 Outside Width: 27.5"
 Bed Height: 15"
 Unit Weight: 25.6 lbs



Jamaica Beach Stacking Chaise

2/pack

Product Specifications

Product Description	Reference Number	Color	UPC Code 014306	Pack Weight Each (lbs.)	Master Pack	Master Pack Volume (cu. ft)
Jamaica Beach Stacking-Chaise White Frame	UT786152	Fern Green	946368	37.50	2	40.44
	UT786006	Blue	945958	37.50	2	40.44
	UT786241	Turquoise	946382	37.50	2	40.44
	UT786019	Orange	946351	37.50	2	40.44
	UT786194	Sky Blue	946375	37.50	2	40.44
	UT786552	Beige	946399	37.50	2	40.44
	UT786004	Straw	946313	37.50	2	40.44
Sandstone Frame	UT786181	Taupe	946344	37.50	2	40.44
French Taupe Frame	UT787181	Straw	946320	37.50	2	40.44

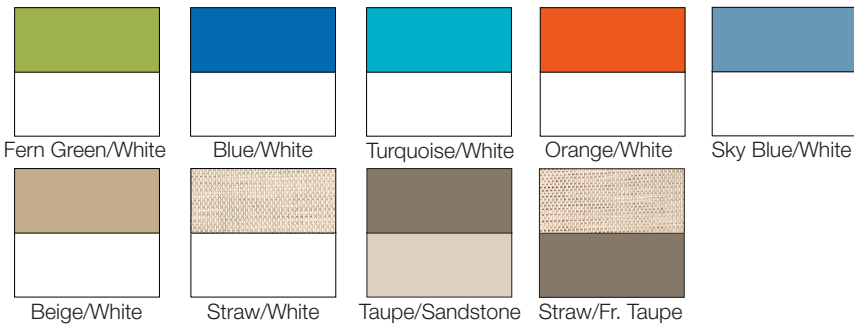

- Passes ASTM Class B performance standard for commercial use
- Versatile sling chaise with many end-uses on both hard and sandy surfaces and at value pricing.
- 4-position adjustable sling chaise lounge for extra comfort
- Highly durable, mildew, stain and fade resistant PVC coated polyester fabric specifically woven to perform in commercial outdoor environments.
- Microban® anti-microbial treatment. Microban® is a registered trademark of Microban International, Ltd.
- Breathable power washable fabric for ease of maintenance.
- Rated to 300 lbs. for structural strength. Tested to 400 lbs. in compliance with ASTM B performance standard.
- Recessed wheels for ease of transportation. Stacks for easy storage.
- Hard wearing footpads for extra wear resistance.

Spare Parts

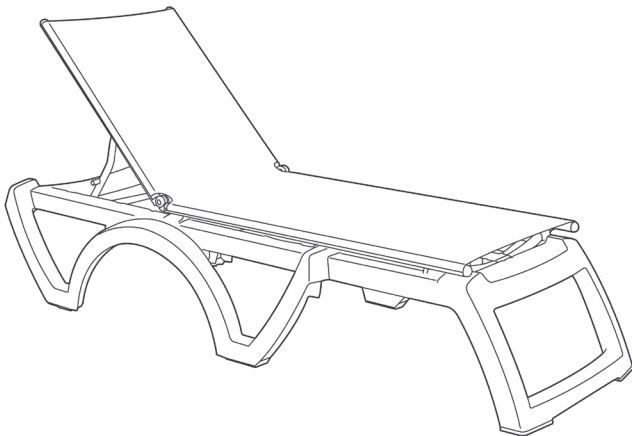

Footpads USSP0293 & USSP0294

Front Footpads (1 right, 1 left)



Middle Footpads (2 footpads)



Rear Footpads (1 right, 1 left)



Reference	Description
USSP0293	JAVA/CAPLYSPO CHAISE FOOTPAD SET WHITE
USSP0294	JAVA/CAPLYSPO CHAISE FOOTPAD SET BLACK
USSP0328	REPL SLING HDW KIT JAVA/JB CHAISE