

# PIZZA PREP. TABLE SIDE MOUNTED CONDENSING UNIT

Project Name: \_\_\_\_\_

Project Location: \_\_\_\_\_

Model #: \_\_\_\_\_ Quantity: \_\_\_\_\_

Available Warehouse: \_\_\_\_\_

**EPP Series**

**Model: EPPR2**



## Refrigeration System

- Side mounted, self-contained and fully detachable Blizzard R290 condensing unit uses environmentally friendly, EPA-compliant R290 refrigerant with zero (0) Ozone Depletion Potential (ODP) and three (3) Global Warming Potential (GWP). Blizzard R290 is easily replaceable and requires no on-site brazing.
- Electronically commutated (ECM) fan motors achieve rapid cooling with less energy consumption.
- Full-length air duct system ensures optimal circulation of cold air.
- Time-initiated and temperature-terminated auto defrost cycle for seamless operation.
- Large capacity, corrosion-resistant condenser and evaporator coils.
- Self-maintaining, energy-efficient condensate drain pan requires no external drains or electric heaters.
- High performance, auto-reverse condenser fan motor supports compressor ventilation and condenser coil cleaning. Refer to owner's manual for full maintenance instructions.
- Pressure relief devices allow smooth access to cabinet interior when re-opening doors.
- Pre-wired and ready to plug, 115V/60Hz/1Ph, NEMA 5-15P.

## Cabinet Construction

- Heavy duty stainless steel interior / exterior with rounded corners for a hazard-free workspace.
- Open spaced interior with no walls between cabinet compartments. Vented stainless steel panel between top pan area and cabinet catches food debris.
- 16 gauge, high quality stainless steel worktop, lid and hood.
- Galvanized steel bottom and rear.
- 2.5" thick high density polyurethane insulation.
- Four 5" swivel casters with locks on front set and two front leg stabilizers.

## Doors

- Heavy duty stainless steel interior / exterior.
- 2.5" thick high density polyurethane insulation.
- Frame heaters prevent exterior moisture build up.
- Self-closing with adjustable torsion system for a positive seal.
- Snap-in magnetic door gasket make cleaning and replacement an easy process.
- High strength, recessed door handles.

## Preparation Area

- NSF certified polycarbonate 6" deep pans (see table for size and quantity).
- 1/2" thick, foam insulated lid keeps top pan area cold and prevents moisture build-up.
- 19 1/4" deep cutting board is removable for ease of cleaning.

## Shelving

- Two epoxy coated, steel wire shelves per section.
- Height adjustable stainless steel clips.

## Temperature Control

- Multi-function digital controller with easy to read LED display.
- Factory preset temperature, 35°F. Temperature setting range from 33°F to 54°F.
- Audible overheat protection alarm for compressor and condenser coil.

## Options

- NSF certified stainless steel double overshef.
- Additional shelving.
- 3" swivel casters with locks.
- 3.5" – 6" height-adjustable and interchangeable legs.



Please visit our website for updated Energy Efficiency information

Ref/ Frz/Dual	Doors	Capacity Cu. Ft.	# of Pans	Shelves	Refrigerant	HP	Power V-Hz-Ph	Amps	Crated Weight	Exterior Dimensions		
										L	D	H*
REF	2	23	1/3x9	4	R-290	1/3	115-60-1	2.5	450 lbs (204kg)	71" (1803mm)	36.5" (927mm)	36.25" (921mm)

(†)Based on evaporating temperature of 23°F (-5°C) & condensing temperature of 131°F (55°C). (►) Product capacity is calculated based on standard industry figures. (✳) Reference plan view for clarification on caster/unit height. If dimensions and capacity are critical, please contact Everest Refrigeration. Blizzard R290 replacement is at the sole discretion of Everest Refrigeration. Specifications subject to change without notice.

# PIZZA PREP. TABLE SIDE MOUNTED CONDENSING UNIT

## EPP Series Model: EPPR2

### DIMENSIONAL DATA

External Dimensions	L	71" (1803mm)
	D	36.5" (927mm)
	H*	36.25" (921mm)
Crated Weight		450 lbs. (204kg)
Doors/Drawers/Lids		2
Max Weight Support (LBS)		-

### STORAGE DATA

Net Capacity Cu. Ft. ▶	23
Shelves	4
Barrels	-
20 oz. Bottles	-
12 oz. Bottles	-
12 oz. Cans	-
8" Mugs	-
# of Pans (Top)	-
# of Pans (Drawer)	1/3x9
Dividers	-
Trays	-

### ELECTRICAL DATA

Voltage	115-60-1
Full Load Amperage	2.5A
Feed Wires with Ground	3
Cord Length	9ft
NEMA Plug Type	 NEMA 5-15P

### REFRIGERATION DATA

Compressor Mounting	Side
Refrigerant	R-290
Compressor HP	1/3
BTU/HR †	N/A

### KEY

D	Door	R	Refrigerator
L	Lid	REF	Refrigerator
H	Half Door	F	Freezer
FD	Full Door	FRZ	Freezer
SD	Solid Door	DUAL	REF/FRZ Combo
GD	Glass Door	DR	Drawer

	Elevation	Right	Plan	3D	Back

### PLAN VIEW

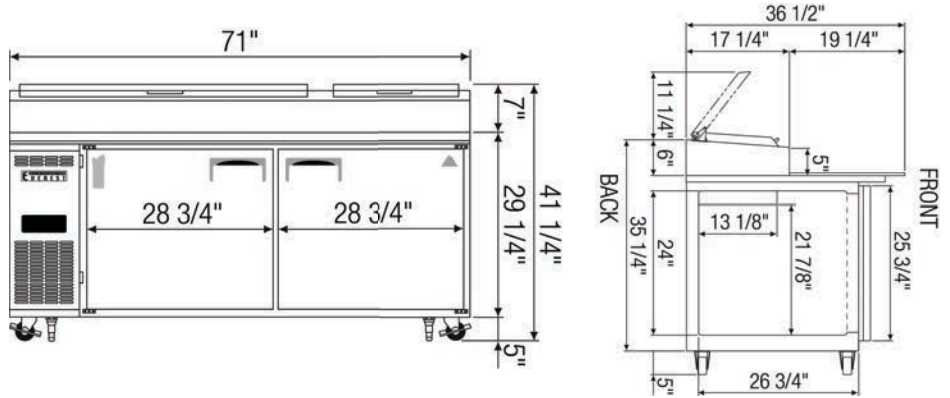

### FRONT

### SIDE

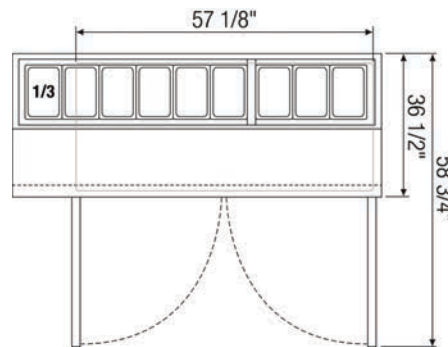

### TOP

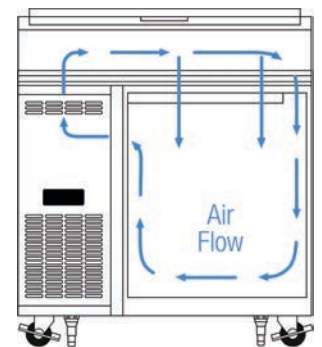

### AIRFLOW

### ACCESSORIES & OPTIONS

Part Number	Description
<b>Additional Shelving</b>	Contact Everest Refrigeration for more information.
<b>AJL03-00</b>	Interchangeable Leg for Caster (Optional)
<b>CASA3-01</b>	3" Overall Height Caster Assembly - (2) Front (2) Rear
<b>OS28-00</b>	Double overshelf (69" L x 13.5" D x 46" H). Adds 31" of height to unit.

(†)Based on evaporating temperature of 23°F (-5°C) & condensing temperature of 131°F (55°C). (▶) Product capacity is calculated based on standard industry figures. (✳) Reference plan view for clarification on caster/unit height. If dimensions and capacity are critical, please contact Everest Refrigeration. Blizzard R290 replacement is at the sole discretion of Everest Refrigeration. Specifications subject to change without notice.