



Project _____
 AIA # _____ SIS # _____
 Item # _____ Quantity _____ C.S.I. Section 114000

R-Series

52" Width Reach-In Even-Thaw Model
 35" Deep, Self-Contained



STANDARD PRODUCT FEATURES

- Special Refrigeration System/Air Flow Design Promotes Rapid, Safe Thawing of Frozen Food Product
- Balanced, Self-Contained Refrigeration System Using R290 Refrigerant
- Variable Speed Compressor Reacts to the Specific Work Environment
- HACCP Compliant
- Designed to Thaw Frozen Food Product (apx. 300 lbs per section) in 24 Hours or Less
- Traulsen's Smart Control with LED Display
- Automatic, Hands-Free Operation (no buttons)
- StayClear™ Condenser Coil
- Stainless Steel Exterior & Interior
- LED Light Controlled by Door Switch
- Stainless Steel One Piece Louver System
- Thermostatic Expansion Valve (TXV Metering Device)
- Full or Half-Height Stainless Steel Doors with Locks
- Self-Closing Doors with Stay Open Feature at 120 Degrees
- Stainless Steel Breaker Caps
- Includes 28 #1 Type Trayslides (14 per section)
- Automatic Non-Electric Condensate Evaporator
- Magnetic Snap-In EZ-Clean Door Gaskets
- Gasket-Protecting Metal Door Liner
- 9' Cord & Plug Attached
- Set of (4) 6" High Adjustable Stainless Steel Legs

ACCESSORIES & OPTIONS

- SmartConnect™ Monitoring App with Wi-Fi Connectivity
- Stainless Steel Finished Back with Rear Louvers
- Plated Shelves to Fit Trayslides
- Door Rehinging Feature
- EZ-Open Foot Pedal (full height doors only)
- Kool Klad Exterior Laminate Decor
- Heat Shield
- Set of (4) 4 1/8" or 6" High Casters in Lieu of Legs
- Stainless Steel Banking Strip
- Other Support Options: 4 1/2" High Base or 6" High Kickplate (for use with standard legs)



Models listed to the applicable UL, CSA and NSF standards by an approved NRTL. Consult the factory or unit data plate for additional information.

AVAILABLE CONFIGURATIONS

R-Series Models

RET232NUT-FHS
 RET232NUT-HHS

Door(s)

Full Height Solid
 Half Height Solid

- GUARANTEED FOR LIFE CAM-LIFT HINGES
- GUARANTEED FOR LIFE HORIZONTAL WORK FLOW DOOR HANDLES (SOLID DOORS ONLY)

*Traulsen's Even-Thaw models are solely intended for thawing, and not for use as holding cabinets.³

Approved by _____ Date _____ Approved by _____ Date _____



R-Series

52" Width Reach-In Even-Thaw Model
35" Deep, Self-Contained

MODEL

RET232NUT-HHS
RET232NUT-FHS

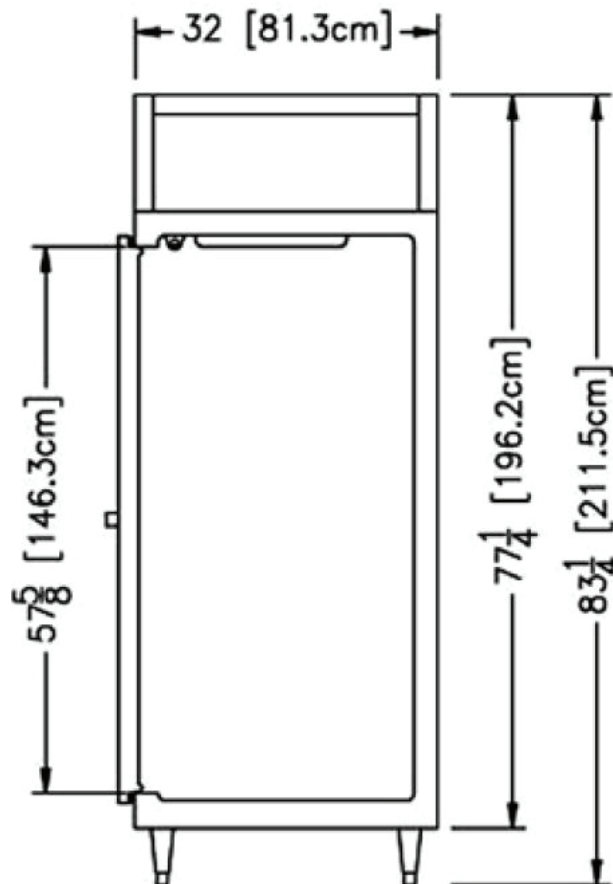
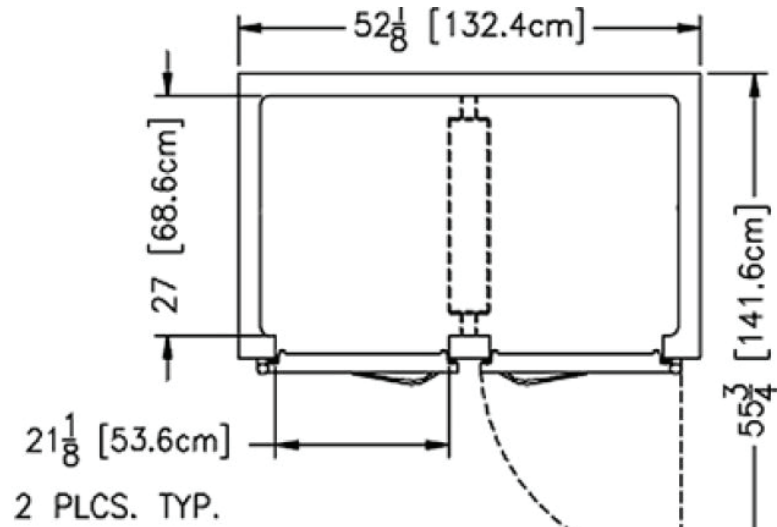

CAD and/or Revit Files Available

<https://traulsen.klccad.com/>



R-Series

52" Width Reach-In Even-Thaw Model

35" Deep, Self-Contained

MODEL

RET232NUT-HHS

RET232NUT-FHS

EQUIPMENT SPECIFICATIONS

MODELS	RET232NUT
DIMENSIONAL DATA	
Net capacity cu. ft.	36.36 (1029.6 cu l)
Length - overall in.	52 1/8" (132.4 cm)
Depth - overall in.	35" (88.8 cm)
Depth - over body in.	32" (81.3 cm)
Depth - door open 90° in.	55 3/4" (141.6 cm)
Clear door width in.	21 1/8" (53.6 cm)
Clear half-door height in.	27 1/2" (69.9 cm)
Clear full-door height in.	57 5/8" (146.3 cm)
Height - overall on 6" legs ²	83 1/4" (211.5 cm)
Pan Capacity - 18" x 26"	28
Pan Capacity - 14" x 18"	56
ELECTRICAL DATA	
Voltage Plug	115/60/1 NEMA 5-15P
Full Load Amperes	7.6
REFRIGERATION DATA	
Refrigerant	R290
Refrigerant Charge Amount oz.	4.8 (136 g)
BTU/HR H.P. ¹	2875 1/2 HP
SHIPPING DATA	
Length - Crated in.	62" (157.5 cm)
Width - Crated in.	42" (106.7 cm)
Height - Crated in.	85" (215.9 cm)
Volume - Crated cu. ft.	128 (3624.6 cu l)
Weight - Crated lbs.	650 (294.8 kg)

NOTES: Figures in parentheses reflect metric equivalents.

1. Based on a 90°F ambient and 20°F evaporator.
2. 12" Top clearance preferred for optimum performance & service access.
3. Traulsen's even thaw's are solely intended for thawing, and not for use as holding cabinets.

When ordering please specify: Voltage, Hinging, and Options.

Equipped with one NEMA 5-15P Plug



CONSTRUCTION, HARDWARE, INSULATION

Cabinet exterior front, one piece sides, louver assembly & door is constructed of heavy gauge stainless steel. Cabinet interior & door liner is also constructed of heavy gauge stainless steel. The exterior cabinet top, back & bottom are constructed of heavy gauge galvanized steel. A set of four (4) adjustable 6" high stainless steel legs are included.

Doors are equipped with removable plug cylinder locks and guaranteed for life cam-lift, gravity action, self-closing metal, glide hinges with stay open feature at 120 degrees. Guaranteed for life, work flow door handle is mounted horizontally over recess in door which limits protrusion from door face into aisle ways.

Gasket profile and EZ-Clean material simplify cleaning and increase overall gasket life. Anti-condensate heaters are located behind each door opening. Cabinet and door contains high density, non-CFC, foamed in place polyurethane insulation.

SELF-CONTAINED REFRIGERATION SYSTEM

A top mounted, self-contained, balanced refrigeration system using environmentally friendly, low GWP R290 refrigerant is conveniently located behind the one piece louver assembly. It features a finless StayClear™ condenser, a large high humidity evaporator coil located outside the food zone, a variable speed compressor and a top mounted non-electric condensate evaporator. Heaters and fans mounted in the mullion facilitate the Even Thaw process. Standard operating temperature is 37-41°F. System automatically reverts to refrigeration operation when product is thawed.

CONTROL

Traulsen's Smart Control features advanced control algorithms & sophisticated diagnostic capabilities to optimize performance. Utilizing Smart Sensors, it adapts the operation of the refrigeration system to a variety of environments & usage patterns. The Smart Control also offers a complete set of visual alarms designed to alert the user to critical events such as power outages or a prolonged door opening. In the event of an alarm, a dedicated Alarm LED will illuminate, informing the user of the critical event and duration.

INTERIOR

Standard interior arrangements include twenty-eight (28) #1 trayslides, fourteen per section. Each pair of trayslides can accommodate either: (1) 18" x 26" or (2) 14" x 18" pans.

WARRANTY

Both a six year parts and labor warranty and a seven year compressor warranty [self-contained models only] are provided standard.

CONTINUED PRODUCT DEVELOPMENT MAY NECESSITATE SPECIFICATION CHANGES WITHOUT NOTICE.