



MAXIMUM-CAPACITY ROTISSERIE - SOLID BACK -
TOUCHSCREEN CONTROLS - CURVED GLASS

VGG-16-C



VGG-16-F-PT model shown

Ideal for extremely high-volume supermarkets and restaurants, the BKI® VGG-16-C has a massive cooking capacity that will meet growing customer demand and improve profitability. This rotisserie can cook up to up to 80 3-lb (1.36 kg) chickens in 75 minutes. The results are delicious—moist and tender inside and perfectly golden brown outside.

The bright touchscreen display makes operation a breeze with true one-touch cooking. Store up to 15 customizable menu programs that can be locked to protect important settings. Select English or Spanish with the new bilingual feature.

Innovative safety features include cool-door technology and sensors that stop rotation when the door is opened.

Whether poultry, pork, beef, vegetables, or your own specialty, the VGG-16-C is sure to maximize customer satisfaction and produce uniform, consistent results every time.

FEATURES AT A GLANCE

- Touchscreen controls
- Curved glass doors
- Lighted cavity to attract customer attention
- Easy-to-clean interior
- Electric operation
- 15 program modes with pre-heat and hold capability
- Cool door for safety
- Solid back design
- 100% hand built in the U.S.A.



PRODUCT CAPACITY

Cooks up to 80 3-lb (1.36 kg) chickens in 75 minutes at the touch of a button.



ELECTRIC OPERATION

Energy efficiency and easy installation are a perfect pairing for your food service operation.



TOUCHSCREEN CONTROLS

True one-touch process controls ensure menu items are perfectly cooked.



COOL-DOOR SAFETY

Double doors insulate to prevent burns; sensors stop rotation and cooking when door is opened.

www.bkideas.com

42 Allen Martin Drive, Essex Junction, VT 05452 • Phone: (802) 658-6600 • Fax: (802) 864-0183

BK1280 Rev A (1/21)

EQUIPMENT DIMENSIONS

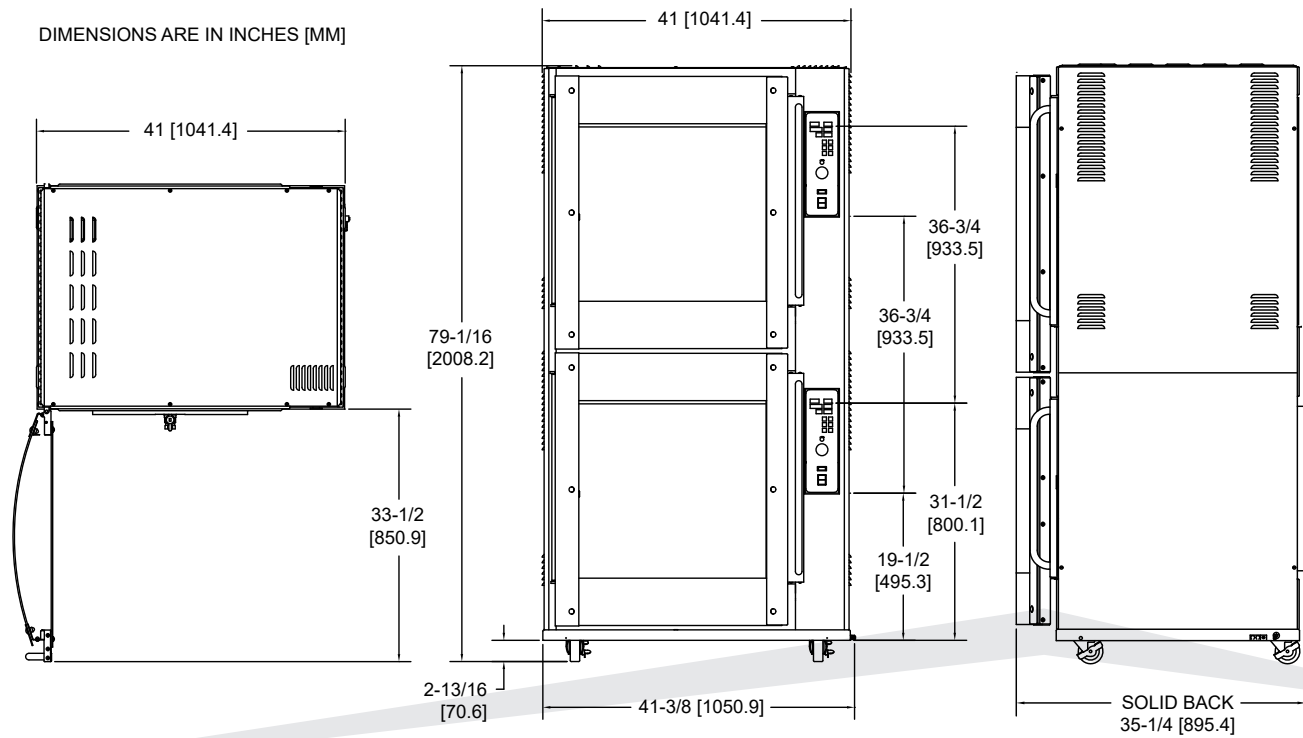

MECHANICAL SPECIFICATIONS

Dimensions	Uncrated	Crated
Height	79 1/16" (2008.2 mm)	88" (2239.2 mm)
Width	41 3/8" (1050.9 mm)	47" (1195.9 mm)
Depth	39 3/8" (1000.1 mm)	45.5" (1157.8 mm)
Floor space	10.6 sq ft (.98 sq m)	14.9 sq ft (1.38 sq m)
Weight	947 lb (429 kg)	982 lb (445.4 kg)

OPTIONS

- Pass-through
- Flat glass
- Drain on drip pan

ELECTRICAL OPTIONS

Volts	Amps*	Breaker*	kW*	Wires	Phase
208	29.7	40	10.6	4	3
220	26.4	35	9.9	4	3
240	28.7	40	11.8	4	3

* Ratings per oven cavity; separate power supply required for each cavity.

230 Volts, 50 Hz 3 Ph+N+E

Volts	Current (A)	Power (W)
L1	31.4	7268
L2	31.3	7200
L3	31.3	7200



Intertek



Intertek



Visit www.bkideas.com to view all accessories available with this model.