

Special Features:

- ✓ 36" Wide Range Top
- ✓ Built In Salamander Broiler, Right Side beneath Griddle
- ✓ Welded Frame Structure Provides Stability
- ✓ Anti-clog standing Pilot Cover Under Each Burner Grate
- ✓ Removable Drip/Crumb Tray with Angled Handle in Front
- ✓ Insulated Stainless Steel Oven Doors with Ceramic Coating
- ✓ U-Shaped Oven Burners
- ✓ Integrated Griddle Comes with Left and Right Splash Guard Installed
- ✓ U-Shaped Griddle Burners Provide Uniform Surface Temperature
- ✓ Kick Plate Cover at Bottom Provides Easy Access for Servicing
- ✓ Removable Burner Grates for Easy Cleaning

Main Description:

The Empura EGR60-GS24_NAT is a 60" wide gas range with (6) 12" x 12" 30,000 BTU top burners, an elevated griddle with a 24" wide x 23 3/4" deep x 3/4" thick cook top, an adjustable built-in broiler rack, and (2) standard ovens. The gas range/griddle combo includes a 24 1/2" high stainless steel backriser with a stainless-steel shelf and a 4" front ledge. This model features a welded frame construction and stands on sturdy 6" adjustable stainless steel legs.

Intended For Commercial Use Only. Empura assumes no liability for component failure, factory defects or any other damages for units installed in non-commercial foodservice or residential applications.

Group Description:

Empura Gas Ranges are an economical choice when you are looking to outfit, replace, or expand your commercial kitchen. Heavy duty construction, cast iron open burners, and built-in ovens make these restaurant ranges a solid, workhorse when you're making soups, stews, pastas, veggies, roasts, breads and more. You can count on an Empura Gas Range for almost any commonplace cooking task you may need accomplished.



TECHNICAL SPECS

Dimensions

Overall Width	60"
Overall Depth	32 5/8"
Overall Height	60 3/8"
Oven Interior Width	26 5/8"
Oven Interior Depth	25 3/4"
Oven Interior Height	13 7/8"
Broiler Opening Height	8 1/4"

Construction

Control Type	Manual
Gas Inlet Size	3/4"
Installation Type	Freestanding
Number of Racks	4
Back Shelf Depth	10"
Front Ledge Depth	4"
Heavy Duty Legs	6"/Stainless Steel/Adjustable

Cooking

Power Type	Natural Gas
Number of Burners	6
Burner Style	Grates
Burner BTU/each	30,000 BTU
Range Base Style	Standard Oven
Number of Ovens	2
Maximum Temperature	550°F
Oven BTU/each	30,000 BTU
Total BTU	276,000 BTU

Griddle

Griddle Position	Right
Griddle Width	24"
Cooking Surface Size (W x D)	20" x 23 3/4"
Griddle Plate Thickness	3/4"
Griddle BTU	36,000 BTU (Griddle & Broiler)

UNIT VIEW

Front View

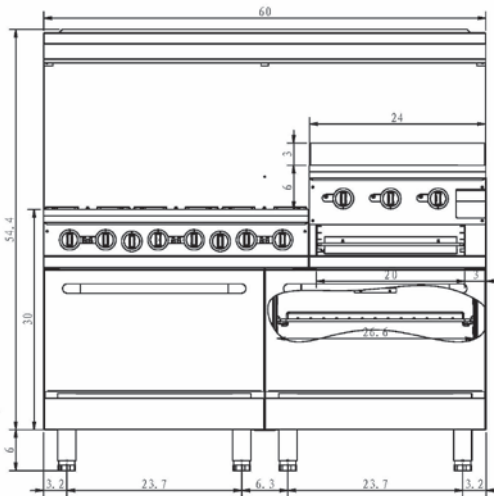

Side View

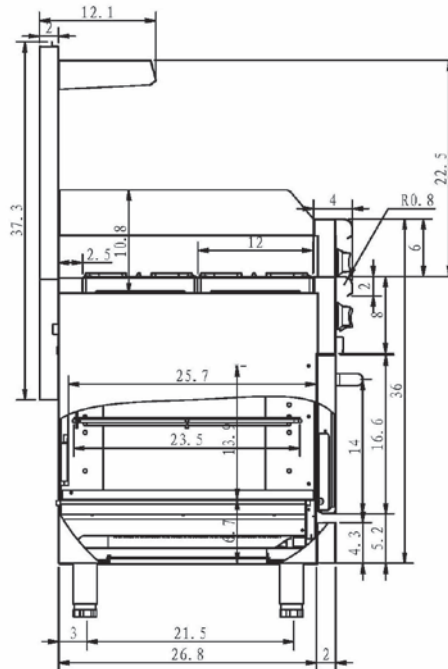

Top View

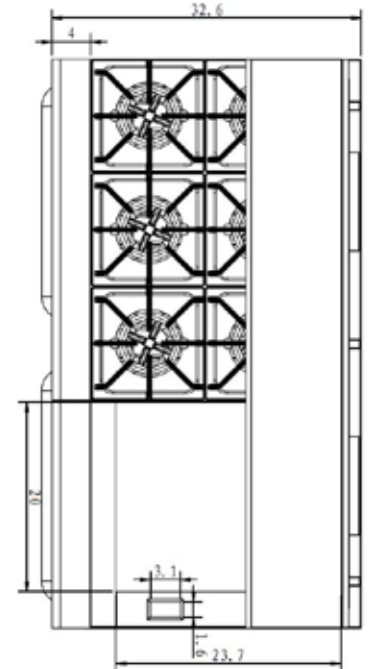

3/4" Gas Connection:
This unit comes with a 3/4" gas connection.



Fuel Type:
This unit is made for use with natural gas.

Attention CA Residents: This product can expose you to chemicals including lead, which are known to the State of California to cause cancer, birth defects, or other reproductive harm. For more information, go to www.p65warnings.ca.gov.