

TURBOJET II COOK CHILL TANK

Project _____
 Item _____
 Quantity _____
 FCSI Section 11400 _____
 Approved _____
 Date _____

Models

- HBCC100



Model shown HBCC100

Standard Features

- Rated capacities for 100 gallons or up to 900 lbs. of product
- Accurate microprocessor operating controls mounted in stainless steel NEMA 4X rated enclosures
- Paperless data recording for permanent recording of water and product temperatures and times
- Core temperature meat probe for controlling cooking and cooling
- Automatic power failure safety control
- Heavy duty stainless steel tank, type 304 construction with adjustable legs
- Rounded internal tank corners for efficient cooling and easy cleaning
- Fully insulated tank with heavy duty stainless steel removable panels
- Automatic water fill and water level controls with over flow protection
- Built-in 5 hp circulating pump for maximum distribution
- High efficiency shell and tube heat-exchanger for faster product cooling
- 72 KW electric heat elements for quick heat up with minimal overshoot of temperature, 3/60/460 volt
- All plumbing connections supplied with line strainers
- Cleaning cycle controls for cleaning and degreasing cook tank and heat exchangers
- Tank includes one complete basket set for products with dolly
- Heavy duty stainless steel gas spring assisted lockable cover
- Accepted for use in U.S.D.A. Inspected Facilities
- NSF/ ANSI standar 169 approved

Short Form Specifications

Shall be Cleveland Model HBCC100 Cook Chill Tank, Rated Capacity of up to 900 lbs. fully insulated, stainless steel tank and circulation pump for optimum water distribution. Solid state controls enclosed in UL rated, stainless steel TYPE NEMA 4X enclosures. Paperless Recording with meat probe for permanent recording cooking times and temperatures. Power failure safety control. Cleaning cycles for degreasing and cleaning the tank and heat exchangers. Tank includes one complete basket set for products with dolly. Lockable gas spring assist cover assembly. Direct expansion refrigerant inline heat exchanger for cooling cycle. Inline electric heat exchanger for precise heating of water for cook cycle.

Options & Accessories

- Extra basket set and dolly
- Hoists for loading and unloading product baskets
- Computer interface connections
- Spare meat probe
- Air power vacuum clipper
- 3/60/230 V electrical
- 3/60/208 V electrical
- Remote mounted 15 Hp air cooled condensing unit
- Remote mounted 15 Hp water cooled condensing unit

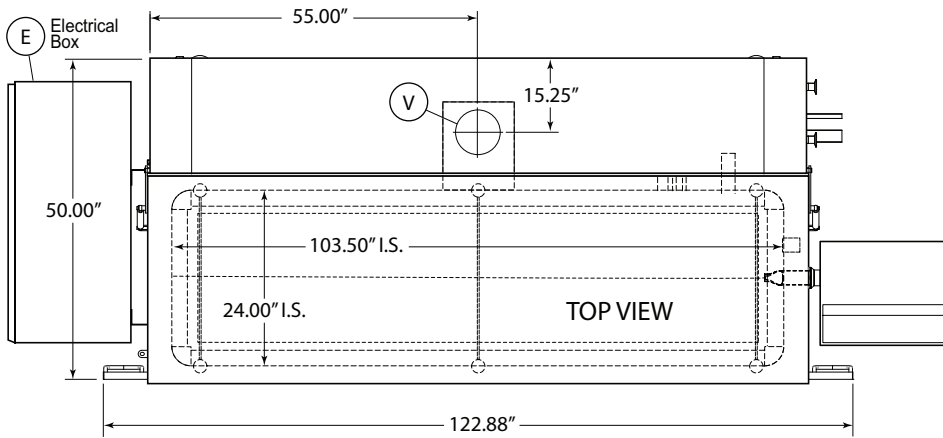

MINIMUM CLEARANCE (as illustrated)	
REAR	24"
RIGHT SIDE	12"
LEFT SIDE	40"
MINIMUM CLEARANCE (with Electrical Box remote mounted for reduced floor space)	
REAR	24"
RIGHT SIDE	12"
LEFT SIDE	8"

Crate Size: 156"L x 56"W x 66"H
Crate Weight: 3,500 lbs
Rate of Class: 85

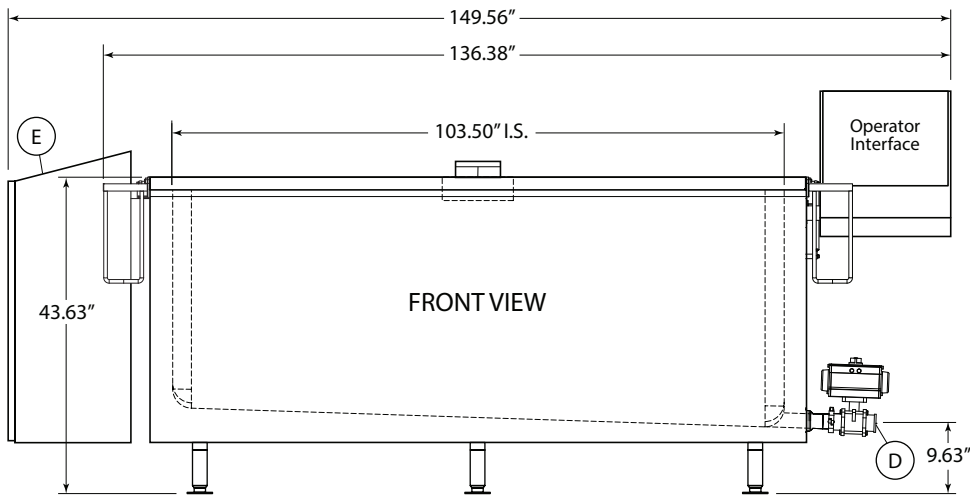

Lorem ipsum

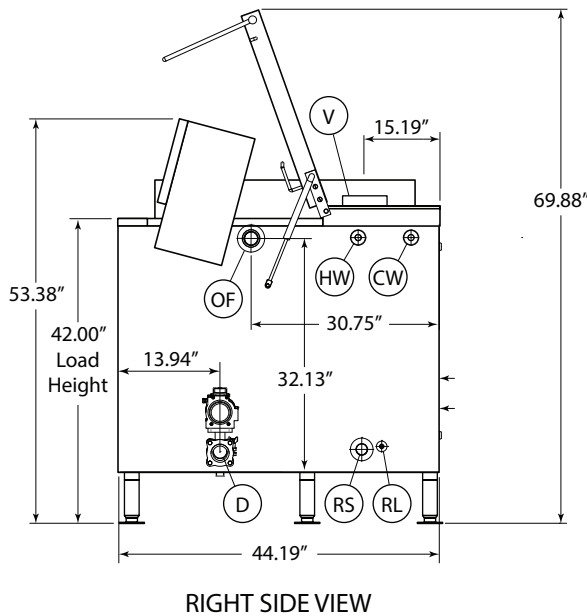

- (CW) **Cold Potable Water:** 1" T-C, 155 Gal. Capacity
- (HW) **Hot Potable Water:** 1" T-C, 155 Gal. Capacity @ 125°F
- (D) **Drain:** 2" T-C, 75 GPM
- (V) **Exhaust Vent:** 6" ID, 200 CFM
- (CA) **Compressed Air:** 1/4" NPT, 5 CFM Req'd @ 90 PSI
- (P) **Pump:** 5 HP, 3 Phase, 3450 RPM
- (RL) **Refrigerant Liquid Line:** 7/8" ODF
- (RS) **Refrigerant Suction Line:** 15/8" ODF, 140,000 BTU/HR @+25° FSST, @95°F Ambient
- (OF) **Overflow:** 1 1/2" FTP
- (E) **Electrical:** 3PH, 60CYC, 208V, 219 Full Load Amps
 3PH, 60CYC, 230V, 205 Full Load Amps
 3PH, 60CYC, 480V, 103 Full Load Amps
 Connections per Local Codes (Customer to specify requirements)

Cleveland Range reserves right of design improvement or modification, as warranted.

(NOT TO SCALE)