

Project _____
 Item _____
 Quantity _____
 FCSI Section 11400 _____
 Approved _____
 Date _____

COMPRESSED AIR SYSTEMS & REFRIGERATED AIR DRYERS

Models

- CAS-5 (VERTICAL)
- CAS-7.5 (VERTICAL)
- CAS-10 (HORIZONTAL)
- CAS-15 (HORIZONTAL)
- CAS-20 (HORIZONTAL)

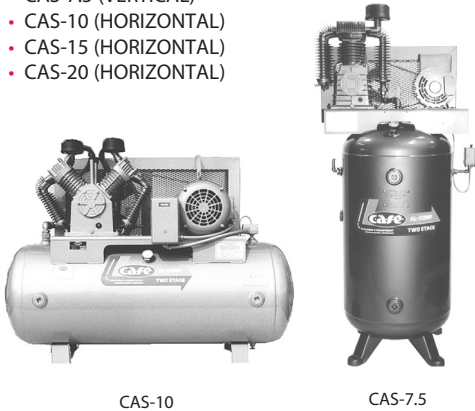

COMPRESSED AIR SYSTEMS

Standard Features

- Air Compressor mounted on A.S.M.E. rated Receiver Tank
- Baldor high efficiency Motor
- Magnetic Starter with Thermal Overloads, completely wired and mounted
- Balanced Pump, external and internal
- Cast Iron Cylinders
- Forged Crankshaft and Pistons
- High quality cast iron Piston Rings
- Cast aluminum Finned Inner Coolers
- Inner Cooler Safety Valve
- Manual Drain for Air Receiver Tank
- Automatic Start and Stop Control
- 14 gauge Belt Guard
- 1/2" Combination Filter/Pressure Regulator/Guage
- 80 gallon Receiver Tank for CAS-5 & CAS-7.5
- 120 gallon Receiver Tank for CAS-10, CAS-15 & CAS-20
- Accepted for use in U.S.D.A. Inspected Facilities

Short Form Specifications

Shall be CLEVELAND Model CAS-_____, COMPRESSED AIR SYSTEM, consisting of Air Compressor & Receiver Tank, ____ H.P. (horse power); High efficiency Baldor Motor with magnetic Starter, Automatic Start and Stop Control; balanced External and Internal Pump; 14 gauge Steel; Belt Guard; 1/2" combination Filter / Pressure Regulator; ____ gallon Receiver Tank.

Options & Accessories

- Vibration Isolation Pads (set of four)
- 3/4" Diameter Stainless Steel Flex Hose
- Refrigerated Air Dryer with 37°F Dew Point
- Programmable, Automatic Drain Valve for Receiver Tank
- Larger models available on request

Models

- CAS-AHT-20 (FOR CAS-5)
- CAS-AHT-30 (FOR CAS-7.5)
- CAS-AHT-40 (FOR CAS-10)
- CAS-AHT-50 (FOR CAS-15)
- CAS-AHT-75 (FOR CAS-20)



REFRIGERATED AIR DRYERS

Standard Features

- Refrigerated air dryer for high inlet temperature
- Unique aluminum technology heat exchanger design
- Precise pressure dew point control over full operating range
- Solid State Controller
- Integrated after-cooler and 3-micron filter / separator
- Dual timed electronic drains with isolation valve and strainer
- Illuminated ON/OFF switch
- Drain set and push to test buttons
- Hot gas by-pass capillary tube controls
- R-134a refrigerant for environmentally friendly applications

Short Form Specifications

Shall be Cleveland Model CAS-AHT _____, Refrigerated Air Dryer for Series "CAS" Compressed Air Systems; precise pressure dew point control over full operating range; dual, programmable electronic timer drains; integrated after-cooler and 3-micron filter / separator; "ACT" aluminum cooling technology for efficient heat transfer, reduced energy consumption and low pressure drop.

COMPRESSED AIR SYSTEM AND AIR DRYER RECOMMENDED PIPING DIAGRAM

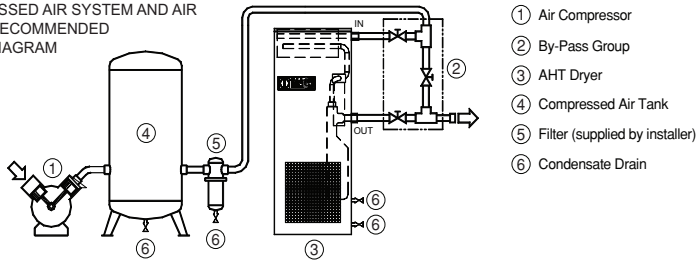

- ① Air Compressor
- ② By-Pass Group
- ③ AHT Dryer
- ④ Compressed Air Tank
- ⑤ Filter (supplied by installer)
- ⑥ Condensate Drain

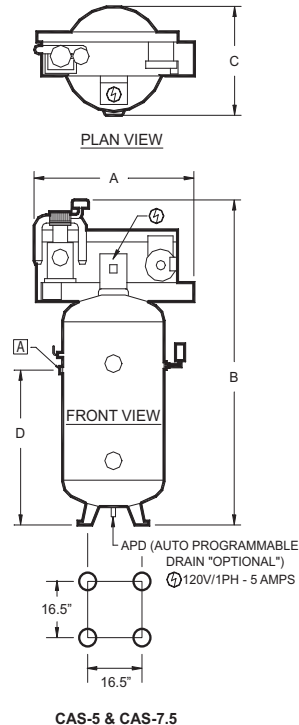

CAS-5 & CAS-7.5

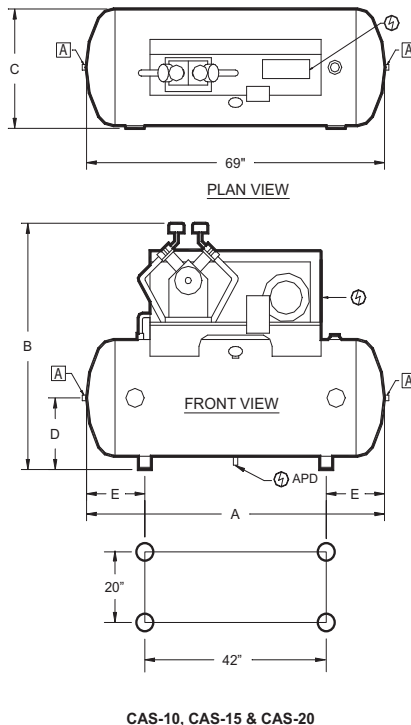

CAS-10, CAS-15 & CAS-20

CAS-AHT-20, 30, 40 & 50

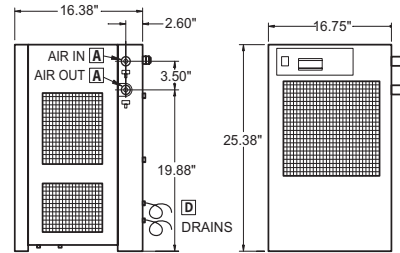

Drain: Each dryer comes fitted with flexible plastics tubing (1/4"dia. x 60"L).

CAS-AHT-75

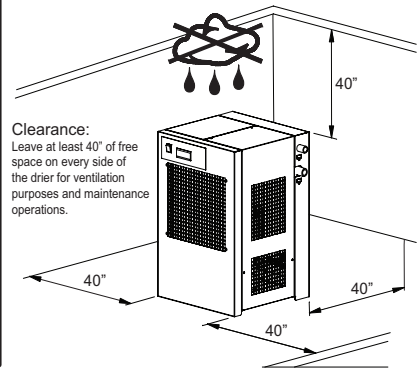
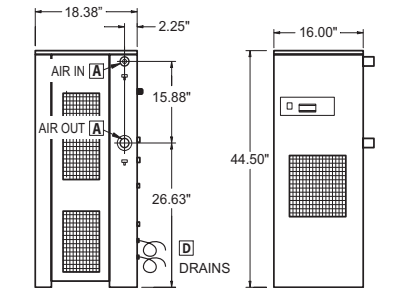

Clearance: Leave at least 40" of free space on every side of the drier for ventilation purposes and maintenance operations.

AIR COMPRESSOR MODELS	A	B	C	D	E	CAPACITY AT 100 PSIG	AIR OUTLET	DRAIN	ELECTRICAL
							[A]	D	208/3/60
CAS-5	37"	74"	26"	40 1/2"	-	19 CFM	2" NPT	1" NPT	15 AMPS
CAS-7.5	37"	79"	26"	40 1/2"	-	26 CFM	2" NPT	1" NPT	22 AMPS
CAS-10	69"	55"	30"	16"	13 1/2"	40 CFM	2" NPT	1" NPT	28.5 AMPS
CAS-15	69"	55"	30"	16"	13 1/2"	47.3 CFM	2" NPT	1" NPT	48.3 AMPS
CAS-20	69"	55"	30"	16"	13 1/2"	58.4 CFM	2" NPT	1" NPT	62.1 AMPS

REFRIGERATED AIR DRYER

MODELS	AIR	AIR FLOW	REPLACEMENT FILTER ELEMENT	REFRIGERANT	DRAIN FLEXIBLE TUBING	ELECTRICAL	SHIPPING WEIGHT
	[A]				[D]	115/1/60*	APPROXIMATE
CAS-AHT-20 (for CAS-5)	1/2" NPT-F	20 SCFM	TP30	R-134a	1/4"	2.7	86 lbs
CAS-AHT-30 (for CAS-7.5)	1/2" NPT-F	30 SCFM	TP30	R-134a	1/4"	3.0	94 lbs
CAS-AHT-40 (for CAS-10)	1/2" NPT-F	30 SCFM	TP30	R-134a	1/4"	3.9	96 lbs
CAS-AHT-50 (for CAS-15)	1/2" NPT-F	50 SCFM	TP45	R-134a	1/4"	5.1	97 lbs
CAS-AHT-75 (for CAS-20)	1" NPT-F	75 SCFM	TP125	R-134a	1/4"	8.9	111 lbs

*Comes standard with Cord & Plug

Cleveland Range reserves right of design improvement or modification, as warranted.

(NOT TO SCALE)

Cook Chill Systems