

This Space for Architect/Engineer Approval

Job Name _____ Date _____

Model Specified _____ Quantity _____

Customer/Wholesaler _____

Contractor _____

Architect/Engineer _____



Black Rubber Bumper

Self-Closing Push Button Cartridge

Black Spray Face

Bonnet

Screw

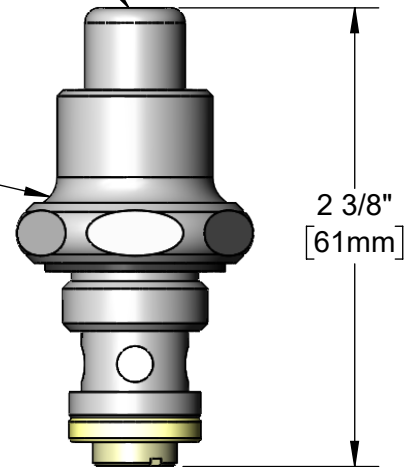

2 3/8"
[61mm]

Model Number

5SV-KIT

Product Specifications:

equip Spray Valve Repair Kit (Includes Bumper Ring, Spray Face, Screw & Bonnet)

Product Compliance:

ASME A112.18.1 / CSA B125.1
NSF 61 - Section 9
NSF 372 (Low Lead Content)
2019 DOE PRSV - Class II

equip
Foodservice
Accessories

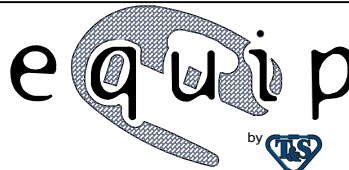

2 Saddleback Cove, P.O. Box 1088
Travelers Rest, South Carolina 29690
Phone: 800.891.4808 Fax: 800.868.0084
equip.tsbrass.com

Drawn: JRM

Checked:

Approved:

Date:

Scale: 1:4

Sheet: 1 of 1



Architect/Engineering Specifications:

Pre-rinse spray valve repair kit with bonnet valve, 1.15 GPM spray face, rubber bumper and screw. Certified to ASME A112.18.1/CSA B125.1, NSF 61-Section 9 and NSF 372. 2019 DOE PRSV - Class II compliant.

Job Name _____

Model Specified _____ Quantity _____

Variations Specified _____

Date _____

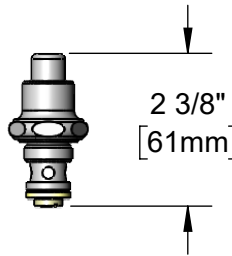

Features & Benefits:

- Black 1.15 GPM pre-rinse spray face
- Spray valve bonnet cartridge
- Black tapered rubber bumper
- Screw
- Material: Plastic spray face, brass cartridge and rubber bumper

Product Compliance:

- ASME A112.18.1 / CSA B125.1
- NSF 61 - Section 9
- NSF 372 (Low Lead Content)
- 2019 DOE PRSV - Class II



Warranty: One Year (Limited)

Performance Data:

- Pressure: 20 - 125 psi
- Temperature: 40°F - 140°F
- Flow Rate: 1.15 GPM @ 60 psi

