



36" Ice Fill Station

Model Number

IFS900-250



FEATURES

- Guillotine and large opening for scoop dispensing
- Full Stainless Steel—front, back, bottom, sides and liner
- Stainless steel baffle prevents ice overflow
- 1 ½" foamed in-place polyurethane insulation
- Adjustable flanged feet
- First in first out ice
- One (1) 48" Clear PVC tube for drainage (1"ID)
- Factory installed stainless steel drain pan
- Welded 40" base frame
- Transparent view windows
- One (1) 250lbs capacity Poly-cart with foot operated rear drain
- Include 48" UHMWP ice paddle



Toll Free Phone: 1-800-346-3246

Local Phone: (303) 761-1615

E-mail: sales@kloppenberg.com

www.kloppenberg.com

ASSEMBLY REQUIRED

- Snout (tool-free)

Model Number

IFS900-250

36" Ice Fill Station

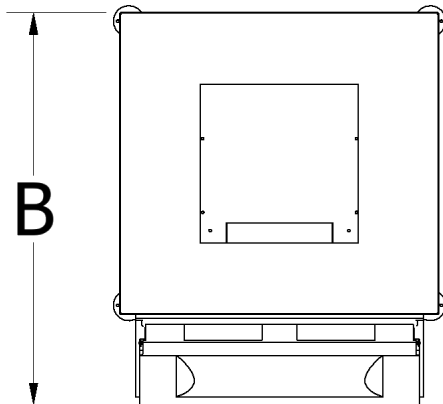

TOP VIEW

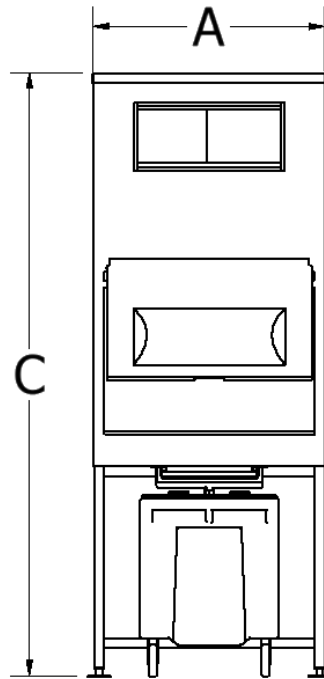

FRONT VIEW

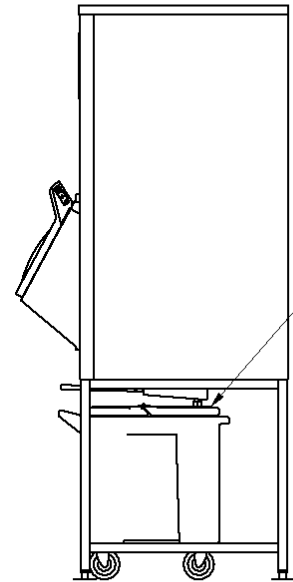

SIDE VIEW

Model Number	Capacity lbs (kg)	A-Width in (mm)	B-Depth* in (mm)	C-Height in (mm)	Minimum Door Clearance in (mm)	Ship Weight lbs (kg)
IFS900-250	1,069 (486)	36 (914)	44.5 (1,130)	112 (2,845)	34 (864)	454 (206)

*Includes 10.5" depth for snout

OPTIONS:

- Fully welded stainless steel liner (coved corners)
- Sleeves for additional capacity

AVAILABLE ACCESSORIES:

- Scoops
- Totes
- Bagging Kit

Toll Free Phone: 1-800-346-3246 Local Phone: 303-761-1615

Email: sales@kloppenberg.comPlease send all PO's to purchaseorders@kloppenberg.com