

MADE IN ITALY



Models:

MCL8E / MCL12E / MCC22E / MCC32E



## Standard Features

- Ideally suited for professional use, hotel, restaurants, butcheries, etc.
- Structure in polished pressure die cast aluminum alloy (MCC version made in Stainless Steel)
- Elegant Stainless steel motor cover
- Immersed gears made from hardened steel
- Ventilated motor (MMC32S only)
- Motor with thermal protection
- Easy-removable micing unit in nickel plated cast iron
- Easy to clean.
- Stainless steel Tray and hub included
- Reversal speed with a push button (MMC32S only)
- Optional sausage Stuffing Kit available
- Optional plate available 3/16 (4.5mm) and 5/16 (8mm)



MCL8E



MCL12E



MCC32E



MCC22E

1-year parts and labor warranty (US Only)

# MEAT GRINDERS



MADE IN ITALY

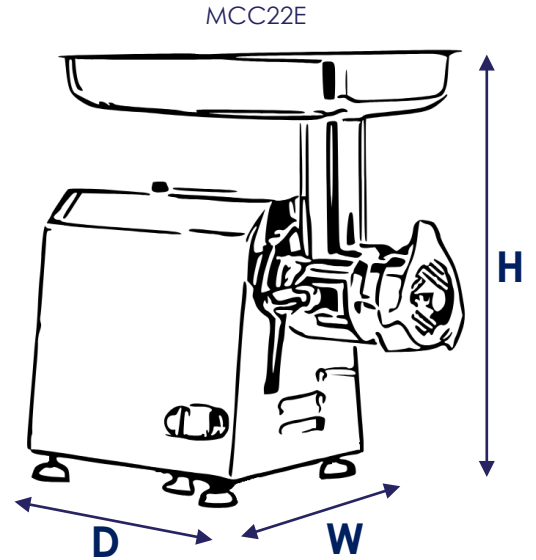
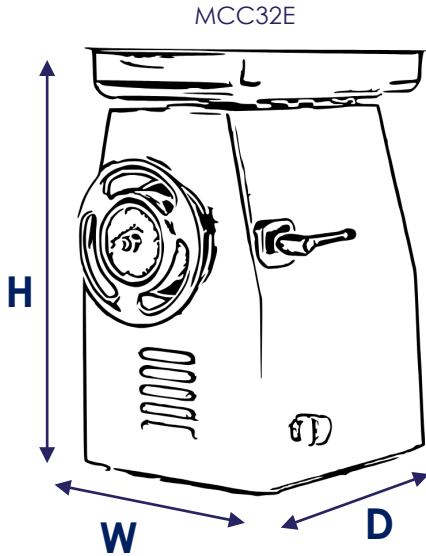

SPECIFICATIONS				
	MCL8E	MCL12E	MCC22E	MCC32
Grinder RPM	80	200	140	140
Feed Mouth Diameter	2"	2"	2"	2"
Production per hour	110 lbs (50 kg)	440 lbs (199.5 kg)	660 lbs (299 kg)	1325 lbs (601 kg)
Hub size	#8	#12	#22	#32
Standard Plate	1/4" (6mm)	1/4" (6mm)	1/4" (6mm)	1/4" (6mm)
Motor Power (Hp)	1/2	1	1 1/2	3
Power Supply	110V/60Hz/1Ph	110V/60Hz/1Ph	110V/60Hz/1Ph	220V/60Hz/1Ph
Amps	5.5	8.5	13	13
Plug / Connection	Nema 5-15p	Nema 5-15p	Nema 5-15p	No plug
Net Weight (lbs)	20	46	59	121
Product Dim. (WxDxH)	10" x 11" x 14"	14" x 9" x 17"	17" x 9" x 17"	19" x 12" x 22"
Shipping Dimension	11" x 16" x 15"	18" x 10" x 18"	19" x 12" x 21"	25" x 17" x 26"



Notes:

- The machine protections and safety devices must not be removed.

MCL8E, MCL12E,  
MCC22E



Nema 5-15  
2 Pole, 3 Wire  
Grounding

MCC32



Wired  
No plug

\*AMPTO is continuously improving products. Specifications are subject to change without notice.\*

MADE IN ITALY



## MEAT GRINDER ACCESSORIES



Sausage Stuffing Kit  
Size: 5/8", 3/4", 1"  
(15/20/25 mm)



RFAM346  
Ring for MCC32S



Grinder Plate  
3/16" 4.5mm



Grinder Plate  
3/16" 4.5mm



Knife Blade



For parts  
[www.ampto.com](http://www.ampto.com)

	MCL8E	MCL12E	MCC22E	MCC32
<b>Stuffing kit optional</b>	N/A	RFAM060	RFAM061	RFAM062 + RFAM346 (sold separately)
<b>Grinder Plate 5/16" - 8mm</b>	N/A	RFAM036	RFAM037	RFAM038
<b>Grinder Plate 1/4" - 4 mm</b>	RFAM352	RFAM039	RFAM040	RFAM041
<b>Grinder Plate 3/16" - 4.5mm</b>	N/A	RFAM030	RFAM032	RFAM035
<b>Knife Blade</b>	RFAM351	RFAM031	RFAM033	RFAM034



Notes:

- Sausage stuffing kit composed by 3 white plastic cones and 1 plastic ring for (MCL8E, MCL12E and MCC22E)
- Only for MCC32S: Sausage stuffing kit composed by 3 white plastic cones (RFAM062) and 1 stainless steel ring (RFAM346) sold separately.
- Grinder plates made in High quality Stainless Steel.
- Knife blade made in High quality Stainless Steel.

\*AMPTO is continuously improving products. Specifications are subject to change without notice.\*