



Profit from the Eagle Advantage®

# Specification Sheet

## Short Form Specifications

Eagle Modular Bag-N-Box Wire Storage System, model \_\_\_\_\_ . Patented QuadTruss® design chrome plated wire shelves for storage and use of syrup boxes. One slanted shelf with 1" front retaining ledge standard. 54" high chrome plated posts with adjustable feet.

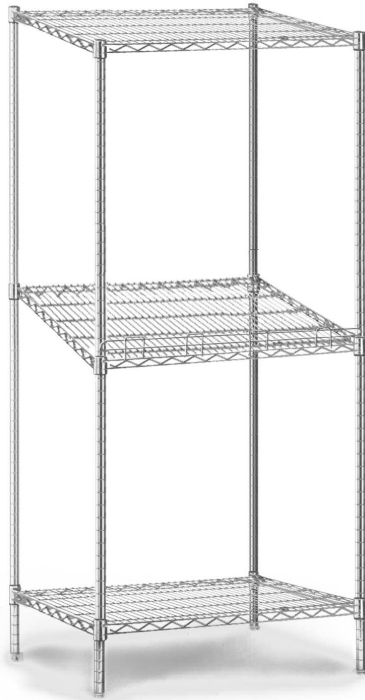

bag-n-box unit

## Options / Accessories

- Additional slanted shelves
- Ledges

**EAGLE GROUP**  
 100 Industrial Boulevard, Clayton, DE 19938-8903 USA  
 Phone: 302-653-3000 • Fax: 302-653-2065  
 www.eaglegrp.com

**Foodservice Division: Phone 800-441-8440**  
**MHC/Retail Display Divisions: Phone 800-637-5100**

For custom configuration or fabrication needs, contact our **SpecFAB® Division**.  
 Phone: 302-653-3000 • Fax: 302-653-2065 • e-mail: quotes@eaglegrp.com

Item No.:	_____
Project No.:	_____
S.I.S. No.:	_____

# Modular Bag-N-Box Systems

## MODELS:

- B2136C
- 2B2136C
- 3B2136C
- B2148C
- 2B2148C
- 3B2148

## Design and Construction Features

- Patented QuadTruss® design (patent #5,390,803), making shelves up to 25% stronger and provides a retaining ledge for increased storage stability and product retention.
- For storage and usage of syrup boxes.
- Each unit has one slanted shelf to allow syrup to run to front of box.
- Front 1" (25mm) ledge is provided on slanted shelf.
- Wire shelves constructed of chrome plated mild steel.
- 54" (1372mm) posts have adjustable feet.
- Shelves adjustable on 1" (25mm) increments.
- All models are provided with a top and bottom straight wire shelf.



EG01.29 Rev. 03/19

**Spec sheets available for viewing, printing or downloading from our online literature library at [www.eaglegrp.com](http://www.eaglegrp.com)**



Item No.: \_\_\_\_\_  
 Project No.: \_\_\_\_\_  
 S.I.S. No.: \_\_\_\_\_

# Modular Bag-N-Box Systems

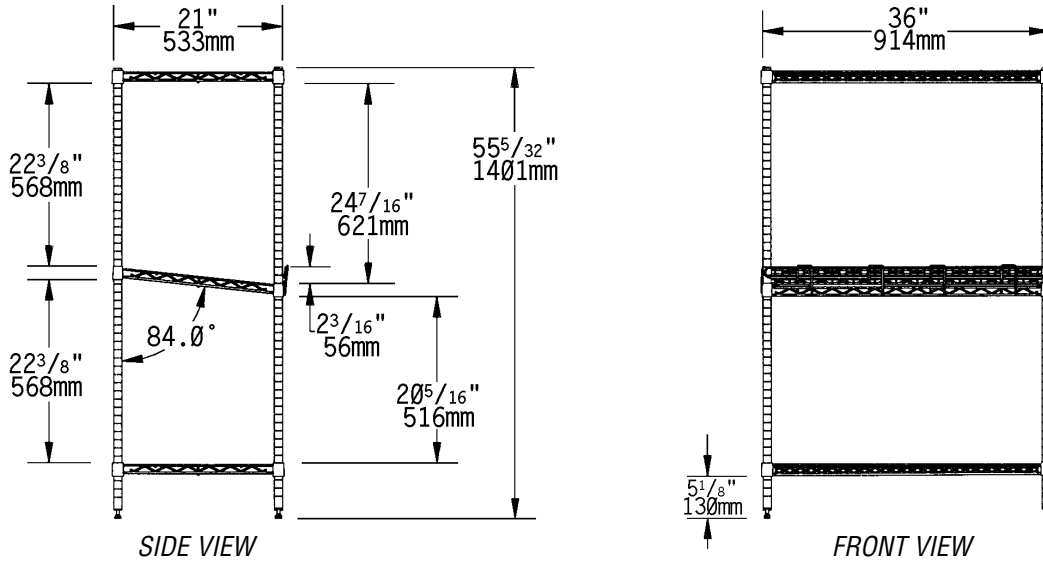

Note: model #B2136C shown

model #	# of shelves & description	width		length		height		weight	
		in.	mm	in.	mm	in.	mm	lbs.	kg
<b>B2136C</b>	1 slanted shelf; 2 straight shelves	21"	533	36"	914	54"	1372	46	20.9
<b>2B2136C</b>	1 slanted shelf; 3 straight shelves	21"	533	36"	914	54"	1372	57	25.9
<b>3B2136C</b>	1 slanted shelf; 4 straight shelves	21"	533	36"	914	54"	1372	68	30.8
<b>B2148C</b>	1 slanted shelf; 2 straight shelves	21"	533	48"	1219	54"	1372	55	24.9
<b>2B2148C</b>	1 slanted shelf; 3 straight shelves	21"	533	48"	1219	54"	1372	69	31.3
<b>3B2148C</b>	1 slanted shelf; 4 straight shelves	21"	533	48"	1219	54"	1372	83	37.6

## Optional Ledges

Chrome-plated.

1" (25mm) LEDGES			4" (102mm) LEDGES			length
model #	lbs.	kg	model #	lbs.	kg	
<b>L14-1C</b>	0.2	0.1	<b>L14-4C</b>	0.8	0.4	14" 356
<b>L18-1C</b>	0.3	0.1	<b>L18-4C</b>	0.9	0.4	18" 457
<b>L21-1C</b>	0.4	0.2	<b>L21-4C</b>	1.0	0.5	21" 533
<b>L24-1C</b>	0.5	0.2	<b>L24-4C</b>	1.2	0.5	24" 610
<b>L30-1C</b>	0.7	0.3	<b>L30-4C</b>	1.4	0.6	30" 762
<b>L36-1C</b>	0.9	0.4	<b>L36-4C</b>	1.6	0.7	36" 914
<b>L42-1C</b>	1.1	0.5	<b>L42-4C</b>	1.8	0.8	42" 1067
<b>L48-1C</b>	1.3	0.8	<b>L48-4C</b>	2.0	0.9	48" 1219

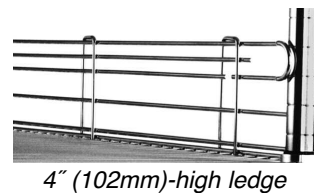
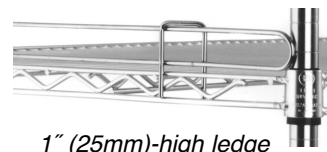

**EAGLE GROUP**  
 100 Industrial Boulevard, Clayton, DE 19938-8903 USA  
 Phone: 302-653-3000 • Fax: 302-653-2065  
 www.eaglegrp.com

Foodservice Division: Phone 800-441-8440  
 MHC/Retail Display Divisions: Phone 800-637-5100

Printed in U.S.A.  
 ©2019 by Eagle Group  
 Rev. 03/19

Spec sheets available for viewing, printing or downloading from our online literature library at [www.eaglegrp.com](http://www.eaglegrp.com)

Although every attempt has been made to ensure the accuracy of the information provided, we cannot be held responsible for typographical or printing errors. Information and specifications are subject to change without notice. Please confirm at time of order.