

Item # _____
 Qty # _____
 Model # _____
 Project # _____



DUKERS
 Quality Commercial Refrigeration



CHARBROILER

DCRB36



Cast Iron Waste and Oil Drain

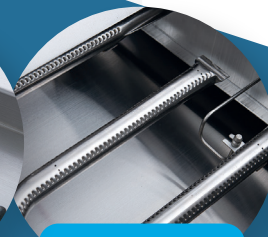

Radiant Burner



Volcanic Stone



Cast Iron Waste and Oil Drain



Charbroiler Knobs



PRODUCT DESCRIPTION

- + Stainless steel exterior and interior.
- + Double wall sides with stainless steel cabinet.
- 🔥 35,000 BTU Burners per 12" section with standby pilots.
- 🕒 Independent manual controls every 12".
- ❄️ "Cool-to-the-touch" front s/s edge.
- 🕒 Each Char Broiler shipped standard Natural gas, LP conversion kit included.
- 📏 Adjustable stainless steel legs, non-skid feet.
- 🌀 Easy to remove full width crumb tray.



HIGH QUALITY STAINLESS STEEL & ROBUST DESIGN

* All measures are presented in Inches

CHARBROILER MODEL	DIMENSION		
	Width	Depth	Height
DCRB36	36 in	28 3/4 in	15 3/8 in



Los Angeles | San Francisco | Dallas
 Houston | Florida | Chicago | New Jersey

1-800-931-8628

@ info@dukersusa.com

www.DukersUSA.com

DETAILS & SPECIFICATIONS

CHARBROILER DCRB36

Front View

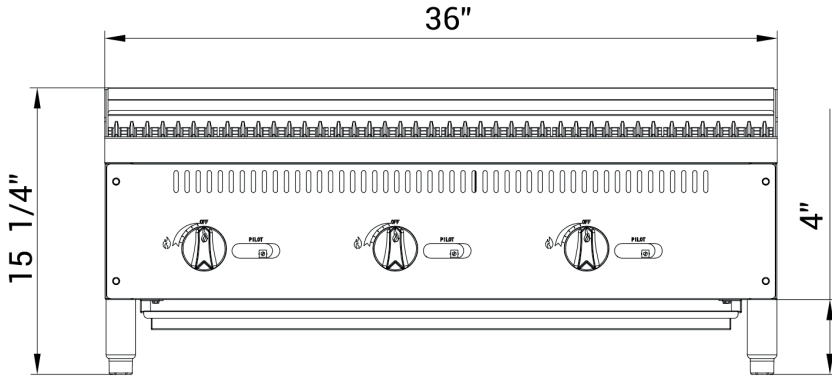

DCRB36

GAS SOURCE	NG/Propane
WORK AREA	35.83x20.47in
BURNER	3 count
SINGLE BURNER	35000 BTU/H
COMBINED	105000 BTU/H
GAS PRESSURE	NG: 4 "WC Propane: 10 "WC
NOZZEL	NG: 34# Propane: 49#
CONTAINER FITMENT	140

Top View

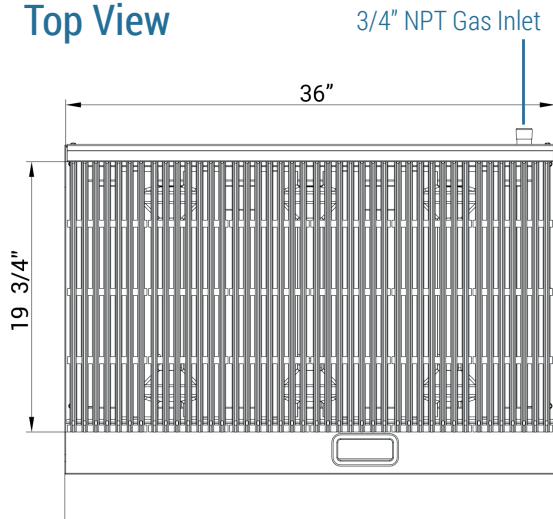

Racks

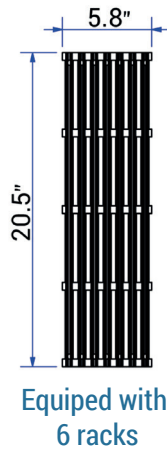

Side View

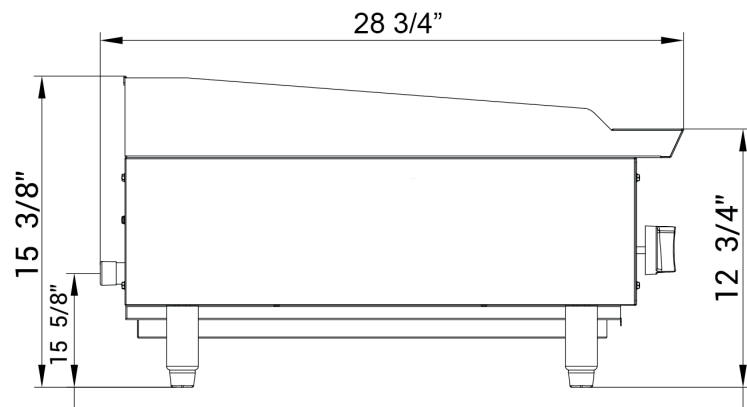

Model	Packaging Dimensions (inches)			Net Weight (lbs)	Ship Weight (lbs)
	W	D	H		
DCRB36	38 1/4"	32 5/8"	20 1/2"	215.2	283.5



Los Angeles | San Francisco | Dallas
Houston | Florida | Chicago | New Jersey

1-800-931-8628

@ info@dukersusa.com

www.DukersUSA.com