



Model SS48

With Alluserv you are not just buying a product. You are receiving our team's service commitment to get the most value from your investment in our products. We will provide you with:

- A team of knowledgeable experts with over 100 years of combined experience to help you understand and receive the most from your product throughout its service life
- Detailed instructions and specification on cleaning and application to best maintain your equipment
- A national service network and service manuals for our extensive product offering.

Tray Starter Station

Models

SS48, SS60, SS72

Standard Features

- All welded stainless steel construction*
- Adjustable-height overshelves, available in three styles
 - ___ Solid stainless steel flat
 - ___ Solid stainless steel angled
 - ___ Open frame angled (accommodates a variety of pan sizes)
- Fixed undershelf inset for comfortable standing
- Choice of three widths
- 3" swivel casters, 2 with brakes

Warranty

- Two years parts and one year labor



*Some assembly required

APPLICATION

Tray Starter Stations are designed for ergonomic tray make up at the front of a conventional meal tray make up conveyor or for a room service meal system. Mobile units can be positioned for optimum productivity and easily moved to storage.

SPECIFICATIONS

Fabricated of 1" square 16-gauge tubing frame with welded construction. Top section includes a combination of three 16-gauge overshelves - flat solid stainless steel, angled (15° pitch) solid stainless steel, and angled open frame to accept a variety of insert pans (12" deep). All overshelves are adjustable in 2" increments. Angled solid stainless steel shelf has front edge lip. Work shelf is 18-gauge with 6" front overhang. Lower 18-gauge storage undershelf is 24" deep. Casters are 3" diameter all swivel, two each with brake. NSF listed.

Spec # _____

AIA # _____

ALLUSERV, LLC

4900 West Electric Avenue | West Milwaukee WI | 53219

888-892-2213 | fax 636-239-8435 | info@alluserv.com | www.alluserv.com

Tray Starter Stations

Models

SS48, SS60, SS72

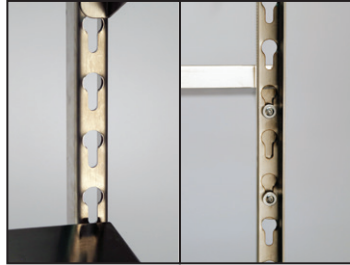

Adjustable Overshelves

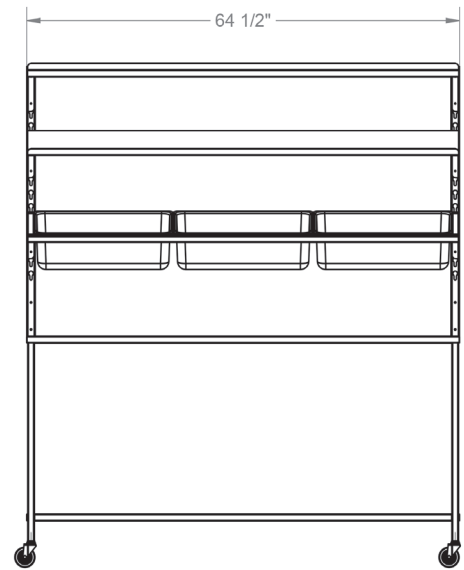

Model SS60

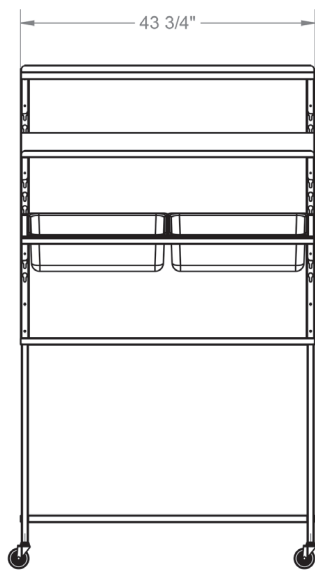

Model SS48

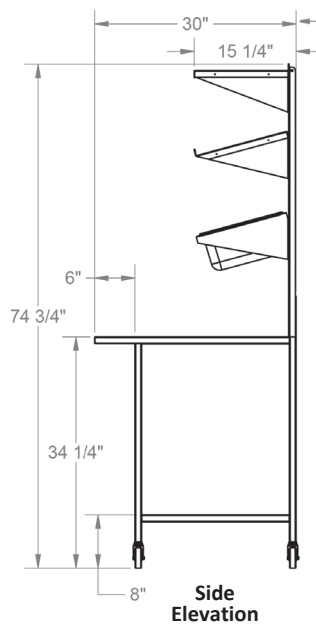

Side Elevation

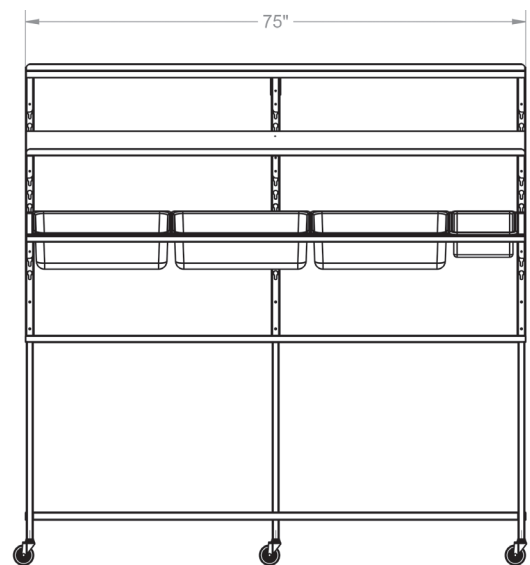

Model SS72

MODEL INFORMATION

MODEL	OPEN FRAME SHELF FULL PAN CAPACITY	OVERALL SIZE			CASTERS		SHIP WEIGHT
		D	W	H	NUMBER	SIZE	
SS48	2	30"	43-3/4"	74-3/4"	4 Ea.	3"	220 lbs.
SS60	3	30"	64-1/2"	74-3/4"	4 Ea.	3"	260 lbs.
SS72	3 + 1/2	30"	75"	74-3/4"	6 Ea.	3"	300 lbs.



4900 West Electric Avenue | West Milwaukee WI | 53219 | 888-892-2213 | fax 636-239-8435 | info@alluserv.com | www.alluserv.com