



EVERPURE® MRS-350BL REVERSE OSMOSIS SYSTEM

CONFIGURABLE SYSTEM THAT DELIVERS REVERSE OSMOSIS WATER FOR MULTIPLE FOODSERVICE APPLICATIONS

MRS-350BL System: EV9970-20, EV9970-35, EV9970-36
Pre-Filter Kit: EV9795-81
7TO-BW Cartridge: EV9627-04
MR-350 Cartridge: EV9627-07
BW 4400 Cartridge: EV9668-24
P5 Cartridge: EV9109-08



APPLICATIONS

Foodservice

Coffee, Espresso, Steam, Reconstitution,
Ice and Multiple Applications

Flash Steamers, Conventional Steamers,
Cheese Melters, Combi Ovens

FEATURES • BENEFITS

The BL Series features an adjustable blend valve, which allows custom tailoring of the dissolved mineral content in the treated water. With this feature a controlled amount of raw water is mixed with the reverse osmosis water to create a blend containing the desired level of TDS (Total Dissolved Solids). After blending, the water passes through a sub-micron carbon filter. This final filtration step removes tastes and odors, and ensures delivery of ingredient quality water

Reduces limescale buildup that can cause excessive machine downtime and increased maintenance costs - plus, scale reduction reduces energy costs

Sanitary cartridge replacement is simple, quick and clean - internal filter parts are never exposed to handling or contamination

Reduces chlorine taste & odor and other offensive contaminants that can adversely affect taste of water and beverages

Wallmount design allows flexible installation

INSTALLATION TIPS

Proper pre-treatment is required to control RO Cartridge (membrane) scale formation and/or fouling.

Contact Pentair Technical Service for pre-treatment recommendations.

Choose a mounting location capable of safely supporting the full weight of the system when in operation.

Never use saddle valve for connection.

Use 3/8" (9.5 mm) minimum water line.

Water inlet must supply a minimum of 1 gpm (3.8 Lpm).

Install vertically with cartridges hanging down and allow 3" (7.6 cm) on all four sides of unit for cover removal and service access.

The product water tubing/piping and associated fittings connecting the RO product outlet to the equipment being serviced should be suitable for use with high purity water.

OPERATION TIPS

Change filter cartridges on a regular six (6) month preventative maintenance program.

Change RO cartridges on a regular two (2) year preventative maintenance program.

Change cartridges when capacity is reached.

Always flush the filter cartridge at time of installation and cartridge change.

Everpure offers a full line of water storage tanks. See "ROmate Storage Tanks" specification sheet or contact your Everpure sales representative for more information.

Refer to Installation, Operation & Maintenance Manual for cartridge flushing and RO startup.

Delimiting of existing water using equipment is recommended.

SIZING

Daily Production Rate:
350 gpd (1,325 Lpd) nominal

Service Flow Rate: Dependent on water pressure in storage tank and line size(s) to equipment.

Operating Pressure Requirements:
25 - 80 psi (1.72 - 5.52 bar), non-shock

EVERPURE® MRS-350BL REVERSE OSMOSIS SYSTEM

MRS-350BL

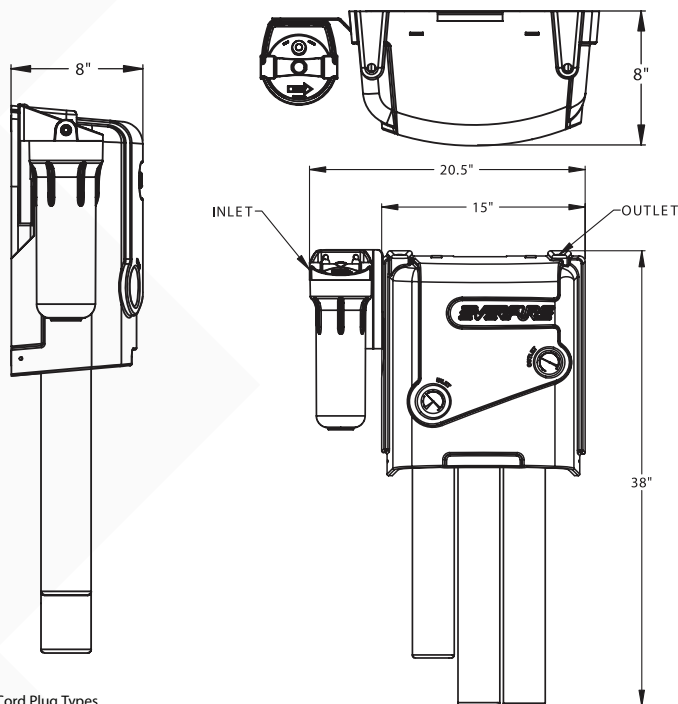

Power Cord Plug Types



NEMA 5-15P

CEE 7/7 "Schuko"

AS 3112

The contaminants or other substances removed or reduced by this drinking water system are not necessarily in your water. Do not use with water that is microbiologically unsafe or of unknown quality without adequate disinfection before or after the system.

WARRANTY

MRS-350/350CC system (excluding replaceable elements) is covered by a limited warranty against defects in material and workmanship for a period of one year after the date of purchase.

Everpure water treatment systems by Pentair® (excluding replaceable elements) are covered by a limited warranty against defects in material and workmanship for a period of five years after date of purchase. Everpure replaceable elements (filter cartridges and water treatment cartridges) are covered by a limited warranty against defects in material and workmanship for a period of one year after date of purchase. See printed warranty for details. Pentair will provide a copy of the warranty upon request.

SPECIFICATIONS

Service Flow Rate

Dependent on water pressure in storage tank and line size(s) to equipment.

Operating Pressure Requirements

25 - 80 psi (1.72 - 5.52 bar), non-shock

Maximum Static Pressure Requirements

100 psi (6.89 bar), non-shock

Available Voltages & Power Cord Types

EV9970-20: 115 VAC/60 Hz NEMA 5-15P
 EV9970-35: 230 VAC/50 Hz CEE 7/7 "Schuko"
 EV9970-36: 240 VAC/50 Hz AS 3112

Minimum Water Supply 1 gpm (3.8 Lpm)

Inlet Temperature 40 - 100°F (4.4 - 38°C)

Overall Dimensions

38" H x 15" W x 8" D
 (96.5 cm x 38.1 cm x 20.3 cm)
 [20.5" W (52 cm) with Pre-filter]
 Add 3" (7.6 cm) on all 4 sides for access.

Inlet and Outlet Connection

3/8" OD tube connection

Wastewater Line Connection

1/4" OD tube connection

Daily Production Rate

350 gpd [1,325 Lpd] nominal (plus tap water addition for processor with blend) Total daily production rate will vary based on tap water TDS, RO percent rejection and desired blend water TDS. Contact Pentair for assistance estimating this total.

Inlet TDS 1,500 ppm max. recommended

Operating Weight

35 lbs (15.9 kgs) (system only)



WATER FILTRATION

EVERPURE-SHURFLO WORLD HEADQUARTERS, 1040 MUIRFIELD DRIVE, HANOVER PARK, IL 60133 USA • FOODSERVICE.PENTAIR.COM
 800.942.1153 (US ONLY) • 630.307.3000 MAIN • 630.307.3030 FAX • CSEVERPURE@PENTAIR.COM EMAIL

EVERPURE-SHURFLO AUSTRALIA, 1-21 MONASH DRIVE, DANDENONG SOUTH, VIC 3175 AUSTRALIA
 011.1300.576.190 TEL • 011.61.39.562.7237 FAX • AU.EVERPURE@PENTAIR.COM EMAIL

EVERPURE-SHURFLO CHINA, 21F CLOUD 9 PLAZA, NO 1118, SHANGHAI, 200052, CHINA
 86.21.3211.4588 TEL • 86.21.3211.4580 FAX • CHINA.WATER@PENTAIR.COM EMAIL

EVERPURE-SHURFLO INDIA, GREEN BOULEVARD, B-9/A, 7TH FLOOR - TOWER B SECTOR 62, NOIDA - 201301
 91.120.419.9444 TEL • 91.120.419.9400 FAX • INDIACUSTOMER@PENTAIR.COM EMAIL

EVERPURE-SHURFLO EUROPE, PENTAIR WATER BELGIUM BVBA, INDUSTRIEPARK WOLFSTEE, TOEKOMSTLAAN 30, B-2200 HERENTALS, BELGIUM
 +32.(0).14.283.504 TEL • +32.(0).14.283.505 FAX • SALES@EVERPURE-EUROPE.COM EMAIL

EVERPURE-SHURFLO JAPAN INC., HASHIMOTO MN BLDG. 7F, 3-25-1 HASHIMOTO, MIDORI-KU, SAGAMIHARA-SHI KANAGAWA 252-0143, JAPAN
 81.(0)42.775.3011 TEL • 81.(0)42.775.3015 FAX • INFO@EVERPURE.CO.JP EMAIL

EVERPURE-SHURFLO SOUTHEAST ASIA, 390 HAVELOCK ROAD, #04-01 KING'S CENTRE, SINGAPORE 169662
 65.6768.5800 TEL • 65.6737.5149 FAX • CSEVERPURE@PENTAIR.COM EMAIL

Pentair trademarks and logos are owned by Pentair plc or its affiliates. Third party registered and unregistered trademarks and logos are property of their respective owners. Because we are continuously improving our products and services, Pentair reserves the right to change specifications without prior notice. Pentair is an equal opportunity employer.