

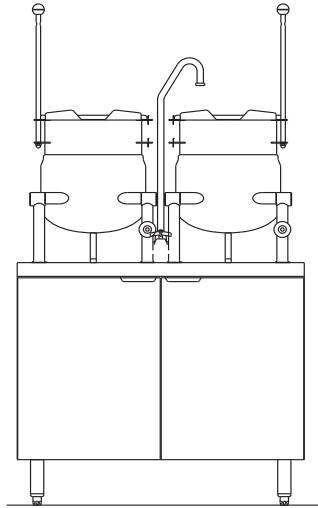

DIRECT STEAM KETTLES ON ELECTRIC CABINET BASE



EMT-10-10

OPERATION SHALL BE BY:

Electrically heated steam boiler operating at 15 psi (103 kPa) and rated at 24 kW.

The boiler shall be equipped for operation on:

- 208 VAC, 1 phase, 50/60 Hz
- 208 VAC, 3 phase, 50/60 Hz
- 220 VAC, 1 phase, 50 Hz
- 220 VAC, 3 phase, 50/60 Hz
- 240 VAC, 1 phase, 50/60 Hz
- 240 VAC, 3 phase, 50/60 Hz

Standard Features

- Water Treatment System
- CSD-1 boiler controls
- Automatic boiler blowdown
- Split water line

OPTIONS & ACCESSORIES

- | | | |
|---|--|--|
| <input type="checkbox"/> 36 kW | <input type="checkbox"/> 415/240 VAC, 3 phase, 50/60 Hz | <input type="checkbox"/> One piece stainless steel lift off cover (C-) |
| <input type="checkbox"/> 42 kW | <input type="checkbox"/> 380/220 VAC, 3 phase, 50/60 Hz | <input type="checkbox"/> Lift-out perforated stainless steel basket (SSB-) |
| <input type="checkbox"/> 48 kW (N/A in 208 and 220 VAC) | <input type="checkbox"/> 575 or 600 VAC, 3 Phase, 60 Hz (EBVS-3) | <input type="checkbox"/> Graduated measuring strip (CMS) |
| <input type="checkbox"/> 380 VAC, 3 phase, 50/60 Hz | <input type="checkbox"/> Etched gallon markings | <input type="checkbox"/> Steam take off kit (STOK) |
| <input type="checkbox"/> 415 VAC, 3 phase, 50/60 Hz | <input type="checkbox"/> Etched litre markings (GM-) | <input type="checkbox"/> Water in "Y" strainer (Condenser feed) |
| <input type="checkbox"/> 480 VAC, 3 phase, 50/60 Hz | <input type="checkbox"/> Correctional package (LM-) | <input type="checkbox"/> Pour lip strainer (TKS) |
| | | <input type="checkbox"/> Nickel plated boiler shell (NPBS) |

STANDARD CONSTRUCTION SPECIFICATIONS

Shall be a Crown model EMT-10-10, consisting of two direct connected steam, tilting kettles, 10 gallon (23 litre).

A double wall kettle interior shall form a steam jacket around the lower 2/3 of the kettle.

The bottom of the kettle shall be of hemispherical design for superior heat circulation.

The kettle interior shall be of 316 stainless steel for high acid content products.

The stainless steel mounting legs shall have the steam supply and condensate within the legs and the right leg fitted with a steam control valve for the kettle.

Each kettle shall be fitted with a tilt handle and heat proof knob, allowing the kettles to be tilted forward 90° for complete emptying.

The kettles mounted on a cabinet base with full perimeter angle frame, reinforced counter, hot and cold water faucet with control valves, 3" (76 mm) deep sinks with drain and splash guard, boiler mountings, CSD-1 boiler controls, automatic boiler blowdown, split water line, hinged doors with magnetic catches, removable side panels and 6" (152 mm) stainless steel legs fitted with 4 adjustable flanged feet for securing to the floor, all #4 stainless steel exterior.

Steam manifold canceled within cabinet fitted with steam trap and safety relief valve.

SEE REVERSE SIDE OF SPEC SHEET FOR WATER TREATMENT SYSTEM STATEMENTS



Approval Notes: _____

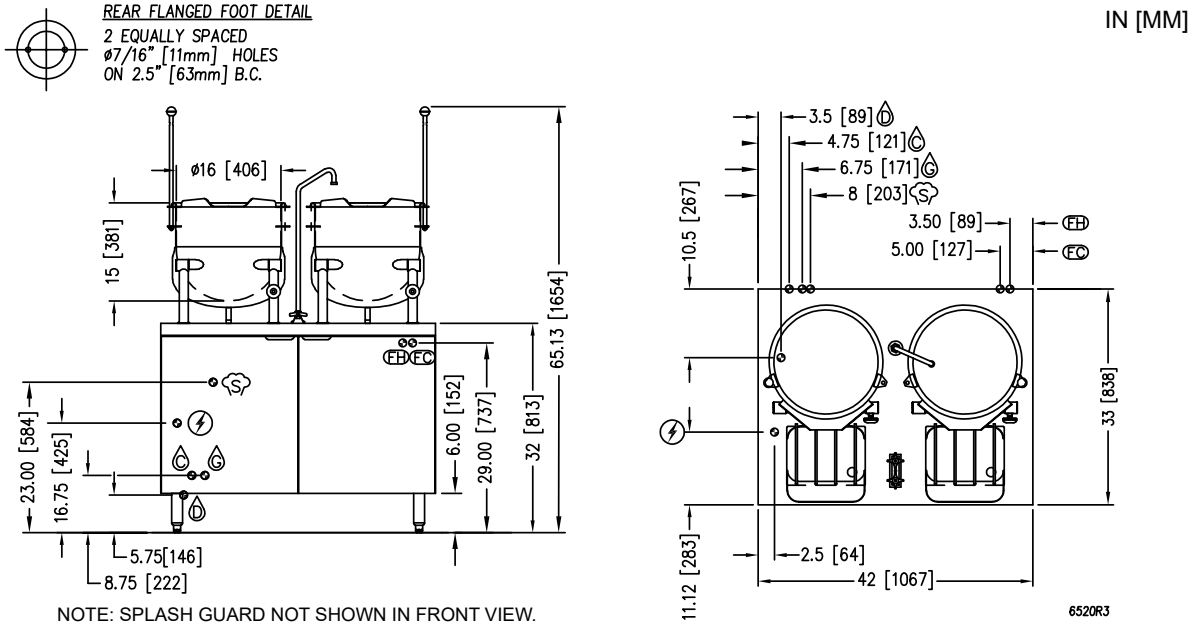

SERVICE CONNECTIONS

- ⚡ – FIELD WIRE ELECTRICAL CONNECTION: Field wiring electrical connection to be as specified on data plate.
- Ⓛ – SINK DRAIN: 2" (51 mm) IPS piped to open floor drain. No Solid Connection.
- Ⓒ – CONDENSATE COLD WATER: 1/2" (13 mm) NPT at 25-50 PSI (170-345 kPa). (OPTIONAL)
- Ⓔ – BOILER FEED WATER: 1/2" (13 mm) NPT at 25-50 PSI (170-345 kPa).
- Ⓕ – FAUCET COLD WATER: 3/8" (10 mm) O.D. tubing at 25-50 PSI (170-345 kPa), NSF-61 compliant.
- Ⓖ – FAUCET HOT WATER: 3/8" (10 mm) O.D. tubing at 25-50 PSI (170-345 kPa), NSF-61 compliant.
- Ⓢ – STEAM TAKE-OFF CONNECTION: 3/4" (19 mm) IPS optional to operate adjacent equipment.

ELECTRICAL CHARACTERISTICS AND SPECIFICATIONS

MODEL	PHASE	kW	AMPS PER LINE					
			208V	220V	240V	380V	415V	480V
EMT-10-10	1	24	115.4	109.1	100	N/A	N/A	N/A
	3	24	66.6	63	57.7	36.5	33.4	28.9
	3	36	99.9	94.5	86.6	54.7	50.1	43.3
	3	42	116.6	110.2	101	63.8	58.4	50.5
	3	48	N/A	N/A	115.5	72.9	66.8	57.7

MODEL	SHIPPING WEIGHT	MINIMUM CLEARANCE
EMT-10-10	720 lbs. [327 kg.]	SIDES 0 [0 mm] BACK 0 [0 mm]

MODEL	CAPACITY
EMT-10-10	(2) 10 gallon (38 litre)

WATER QUALITY STATEMENT

Water is the essential ingredient in steam equipment, water quality is the major factor affecting the performance of your appliance. Crown Steam Group offers a Comprehensive Water Treatment System which exceeds our minimum water requirements. Proof of installation and proper cartridges replacement is required for warranty coverage. Water supply to Crown Steam Group steamers must be within these guidelines.

Total dissolved solids.....	Less than 60 PPM	Chlorine	Less than 1.5 PPM
Total alkalinity	Less than 20 PPM	pH Factor	6.8 - 7.3
Silica.....	Less than 13 PPM		

Water which does not meet these standards should be treated with the installation of Middleby's Water Treatment System. Call 919-762-1000 if you have questions concerning your water meeting these parameters.

*Failure or malfunction of this appliance due to poor water quality is not covered under warranty.
Reference www.crownsteamgroup.com for complete warranty details and instructions.

DISCLAIMER

Terry System Cartridge Changes / Installation – "2-3 gallons of water **MUST** be purged at each cartridge change or new installation prior to water supply being fed to the steamer. Failure to do so can result in component damage within the steamer which is not covered under warranty. For additional guidance on proper installation, refer to install documentation provided with each Terry System and Replacement Cartridge Set."

**INTENDED FOR COMMERCIAL USE ONLY.
 NOT FOR HOUSEHOLD USE.**

