



Rolling Tortilla Warmer

RTW14EA RTW19EA



RTW19EA shown
patent no. 9,516,883

DESCRIPTION

The patent pending RTW rolling tortilla warmers are designed to heat tortillas, pitas, and other flatbread products up to 3/8-inch (10 mm) thick evenly, efficiently, and in a matter of seconds. The compact design is ideal for any location and can be wall-mounted for further convenience.

SPECIFICATIONS

The RTW-series rolling tortilla warmers will be constructed in the U.S.A. with a corrosion-resistant stainless steel body. Units will be supplied with electronic controls to adjust temperature up to a maximum of 480° F (249° C) and adjust drum speed. Each unit will be capable of heating up to 24 - six [6] inch (152mm) tortillas or 10 - twelve [12] inch tortillas to a target temperature of 160° F (71° C) per minute. Both upper inlet tray and lower output tray will be included and will be constructed of stainless steel. Units will come with four [4] inch (102 mm) legs. The power on the RTW14EA will come as a 120 V [5-15P plug] version or a 208-240 V [6-15P plug] version. The RTW19EA will be 208-240 volts, single phase, and will use a 6-15P plug. Both units will use a six [6] foot (1.83 m) power cord.

WARRANTY

These units come with a one [1] year warranty for parts and labor.

FEATURES

- Heats products to a target temperature of 160° F (71° C) in a matter of seconds.
- RTW14EA models can heat up to 900 6-inch (152 mm) tortillas per hour and RTW19EA models can heat up to 1,350 6-inch (152 mm) tortillas per hour.
- Electronic control allows easy and precise adjustment of the thermostat up to 480° F (249° C) and quick changes to drum speed.
- Efficient radiant heating uses substantially less energy and cuts down on excess heat outside of the unit for a cooler working environment.
- Top cover swings open and upper and lower tray remove for easy cleaning.
- Sunology™ drum coating is easy to clean and exceptionally durable.

OPTIONAL ACCESSOIRES

- Wall mount kit [RTW14EA-WMB shown]
- Wall mount kit [RTW19EA-WMB*]
- RTW Scraper Kit [9D-SCRAPER-RTW]

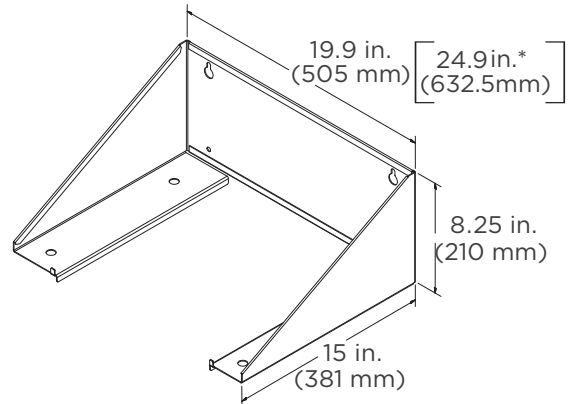

SK3187 REV - (08-23)

CERTIFICATIONS



STAR MANUFACTURING INTERNATIONAL INC.
265 Hobson St. • Smithville, TN 37166
Telephone: 800 264 7827 • www.star-mfg.com



Rolling Tortilla Warmer

RTW14EA RTW19EA

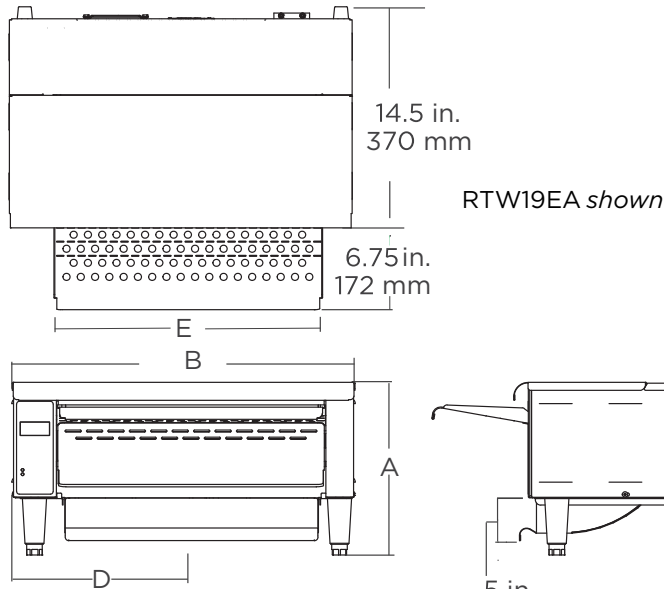

CLEARANCES

Please allow at least ten [10] inches (254 mm) of space to open the top for cleaning if the unit is to remain stationary. There should be at least one [1] inch (25 mm) of clearance on each side and behind the unit as well.

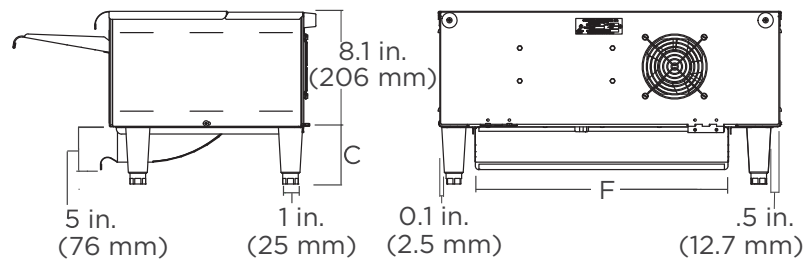

SK3188 REV - (08-23)

MODEL	HEIGHT [A] in. (mm)	WIDTH [B] in. (mm)	DEPTH in. (mm)	LEG HEIGHT [C] in. (mm)	VOLTS ¹	AMPS	WATTS	NEMA PLUG	APPROX. SHIP WEIGHT	APPROX. WEIGHT INSTALLED
RTW14EA ¹	13 (305)	19.6 (498)	21.3 (541)	5 (102)	120 208 240	14.9 6.3 7.2	1.787 1.351 1.787	5-15P 6-15P	69 lb. (31.4 kg)	50 lb. (22.7 kg)
RTW19EA ¹	13 (305)	24.0 (610)	21.3 (541)	5 (102)	208 240	9.1 10.5	1905 2537	6-15P	77 lb. (35.0 kg)	62 lb. (28.1 kg)

MODEL	CORD DISTANCE FROM CONTROL SIDE [D]	CORD DISTANCE FROM CONTROL REAR	INLET TRAY WIDTH [E]	OUTPUT TRAY WIDTH [F]
RTW14EA ¹	12.2 (310)	2.1 (53)	14.1 (358)	13.0 (330)
RTW19EA ¹	14.0 (356)	2.1 (53)	18.9 (480)	18.0 (457)

¹Specify 208V, 240V Service when ordering

Due to periodic changes in designs, methods, procedures, policies and regulations, the specifications contained in this sheet are subject to change without notice. While Star Manufacturing exercises good faith efforts to provide information that is accurate, we are not responsible for errors or omissions in information provided or conclusions reached as a result of using the specifications. By using the information provided, the user assumes all risks in connection with such use.



STAR MANUFACTURING INTERNATIONAL INC.
265 Hobson St. • Smithville, TN 37166
Telephone: 800 264 7827 • www.star-mfg.com

Printed in the U.S.A. • 2M-Z21286 REV F (08-23)
Specifications are subject to change without notice
and are not intended for installation purposes.