

- **NR3640RSV** 35-3/4"L x 33"D x 39-3/4"H
- **NR4840RSV** 47-3/4"L x 33"D x 39-3/4"H
- **NR6040RSV** 59-3/4"L x 33"D x 39-3/4"H
- **NR7240RSV** 71-3/4"L x 33"D x 39-3/4"H

### Included

- NOTE: Glass warranty only applicable to first point of delivery
- Breeze~E (Type-II) self-contained refrigeration
- (1) Level of clear glass shelving removable and adjustable on 1" centers
- Compressor air intake from rear and out front panel at toe kick. Front panel cannot be blocked.
- Condensate pan (self-contained refig. only)
- LED top & shelf lights
- One piece formed ABS plastic tub
- One year parts & labor; 5 year compressor warranty
- Vertical, fixed front & side UV bonded frameless glass
- Warmest average product temperature of 40°F or less



**NR4840RSV**

Specify	Standard Features	Additional Options
<b>FRAME EXTERIOR COLOR</b>	• Black	• Powder coated (stock/non-stock colors) • Stainless steel
<b>INTERIOR COLOR</b>	• Powder coated Silversan Black	• NOTE: Interior color must be FDA & NSF approved • Powder coated (stock colors, specify RAL#) • Stainless steel
<b>LOWER FRONT PANEL COLOR</b>	• Powder coated Silversan Black	• Powder coated (stock colors, specify RAL#) • Stainless steel
<b>PANEL EXTERIOR</b>	• Laminate (stock colors)	• Laminate (non-stock colors) • Stainless steel
<b>BASE SUPPORT</b>	• Adjustable, locking casters (self-cont.)	• 6"H legs (self-cont.) • Shims (remote)
<b>END PANELS</b>	• Full end panel	• None (specify per line-up)
<b>LOWER REAR PANEL</b>	• Powder coated Silversan Black	• Powder coated (stock colors, specify RAL#) • Stainless steel
<b>REAR DOORS</b>	• Clear glass rear sliding doors	• Reflective glass rear sliding doors
<b>LIGHTS</b>	• LED 3500K w/ frosted lens	• LED 3000K w/ frosted lens • LED 4000K w/ frosted lens
<b>ELECTRICAL CONNECTION</b>	• 10' Straight blade power cord (self-cont.)	• 10' Locking power cord (self-cont.) • Electrical leads (remote)
<b>REFRIGERATION</b>	• Breeze~E (Type-II) self-contained refrigeration (rear access)	• Breeze~E (Type-II) self-contained refrigeration (front access) • Remote w/thermostat, solenoid & TXV (front access) • Remote w/thermostat, solenoid & TXV (rear access)
<b>MISCELLANEOUS</b>		• 14.5" Base height extension • Rear door lock • Second year parts & labor warranty (excludes compressor)
<b>ACCESSORIES</b>		• Clean Sweep® coil cleaner (self-cont.)

Option Notes: 1 - Cannot be combined w/ 6"H legs

<b>Intended Environment:</b> Type II - Designed to operate in ambient conditions of 80°F and 55% relative humidity unless noted otherwise in system information below.		
<b>Zone</b>	<b>Intended Product To Be Displayed</b>	<b>Warmest Avg Prod Temp ° F</b>
1	Unpackaged refrigerated products	40

### PLAN VIEW

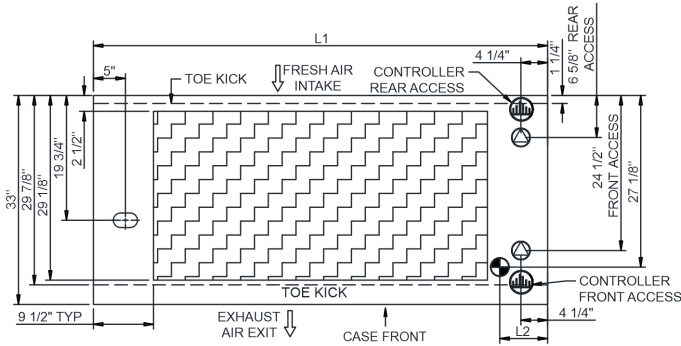

### SIDE VIEW

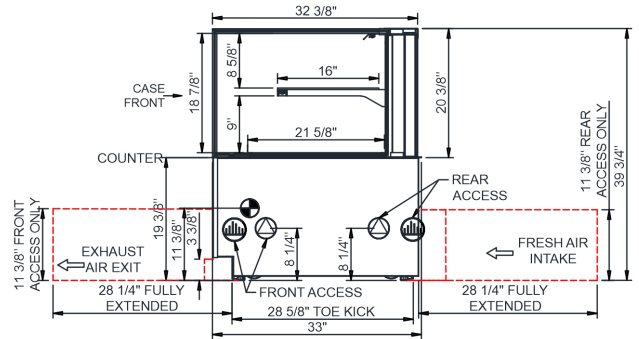

R290 SELF-CONTAINED ACCESS DIMENSIONS PROVIDED.  
CONTACT FACTORY FOR ALL OTHER SELF-CONTAINED ACCESS DIMENSIONS

	"A"	"B"	"C"	"D"	"M"	"N"
NR3640RSV	8 1/2"	16 3/4"	8 1/2"	10 1/2"	14 1/2"	17 3/8"
NR4840RSV	8 1/2"	28 3/4"	8 1/2"	10 1/2"	20 1/2"	17 3/8"
NR6040RSV	8 1/2"	40 3/4"	8 1/2"	10 1/2"	26 1/2"	17 3/8"
NR7240RSV	8 1/2"	22 3/4"	8 1/2" x2	10 1/2"	32 1/2"	17 3/8"

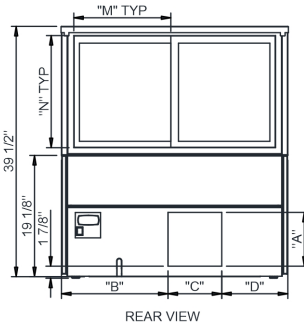

#### NOTES:

- 11 3/8" TALL, FULL WIDTH OF CASE OPENING IN CABINET OR COUNTER IS REQUIRED TO PULL OUT REFRIGERATION SYSTEM.
- SEE DESIGN GUIDE FOR CUTOUT SIZE IN CABINET FOR CASE TO DROP INTO.
- BACK OF COUNTER / CABINET MUST BE VENTED PROPERLY FOR ADEQUATE AIRFLOW TO CONDENSER.
- \*\*REPRESENTS REAR PULLED REFRIGERATION. AIR FLOW INTAKE AND EXIT DETAILS ARE REVERSED WITH FRONT PULLED REFRIGERATION OPTION.
- SELF-CONTAINED ACCESS ONLY BY PULLING OUT CONDENSER UNIT.
- SEE "COUNTER INSTALLATION GUIDE" FOR AIR FLOW REQUIREMENTS.

NOTE: ALL DIMENSIONS APPROXIMATE

- ELECTRICAL JUNCTION BOX (SUPPLIED WITH 6" LEADS OR POWER CORD).
- LOCATION OF DRAIN TUBE FOR REMOTE REF. ONLY (SUPPLIED WITH 3/4" OR 1 1/2" PVC TUBE).

- REFRIGERATION LINE CONNECTION.
- REMOTE FLOOR SINK & UTILITIES ACCESS AREA.

- SELF-CONTAINED CASE SERVICE ACCESS AREA.
- DRY CASE SERVICE ACCESS AREA.

Model Technical Specifications																
Model	L"	L1"	L2"	System Circuit Volts		Phs	Freq	Amps ***	Watts	Wires	NEMA Plug	SST	Conv. Rack BTUH	Para. Rack BTUH	Est Wt	
NR3640RSV	N/A	35.75	7.50	Remote (DX)	Circuit #1	110-120	1	60	1.08	32	2+G	Leads Single	24.00	864	800	
				Self-Contained (R290)	Circuit #1	110-120	1	60	10.73	957	2+G	5-15P or L5-15P	N/A	N/A	N/A	
				Self-Contained (R513A)	Circuit #1	110-120	1	60	9.76	762	2+G	5-15P or L5-15P	N/A	N/A	N/A	
NR4840RSV	N/A	47.75	7.50	Remote (DX)	Circuit #1	110-120	1	60	1.08	35	2+G	Leads Single	24.00	1123	1040	
				Self-Contained (R290)	Circuit #1	110-120	1	60	11.18	985	2+G	5-15P or L5-15P	N/A	N/A	N/A	
				Self-Contained (R513A)	Circuit #1	110-120	1	60	9.76	765	2+G	5-15P or L5-15P	N/A	N/A	N/A	
NR6040RSV	N/A	59.75	7.50	Remote (DX)	Circuit #1	110-120	1	60	1.38	52	2+G	Leads Single	20.00	1382	1280	
				Self-Contained (R290)	Circuit #1	110-120	1	60	11.18	991	2+G	5-15P or L5-15P	N/A	N/A	N/A	
				Self-Contained (R513A)	Circuit #1	110-120	1	60	10.06	782	2+G	5-15P or L5-15P	N/A	N/A	N/A	
NR7240RSV	N/A	71.75	7.50	Remote (DX)	Circuit #1	110-120	1	60	1.38	55	2+G	Leads Single	20.00	1642	1520	
				Self-Contained (R290)	Circuit #1	110-120	1	60	11.18	998	2+G	5-15P or L5-15P	N/A	N/A	N/A	
				Self-Contained (R513A)	Circuit #1	110-120	1	60	9.86	774	2+G	5-15P or L5-15P	N/A	N/A	N/A	

\*\*\* Does not include electric defrost on freezer models.

#### Regulatory Approvals:

All Models  
 Accordance with AHRI Std 1200  
 ETL Listed to UL 471  
 ETL Listed to CAN/CSA 22.2 No. 120  
 ENERGY STAR®  
 ETL Sanitation to NSF/ANSI 7



In Accordance with  
**AHRI Std 1200**

**DOE 2017**  
Energy Efficiency  
Compliant



#### Important Notes:

- 1) ELECTRICAL NOTE: If GFCI is required, a GFCI breaker MUST be used in lieu of a GFCI receptacle
- 2) Back side of counter must be open or vented the full length of the unit to allow proper ventilation for the refrigeration system.
- 3) Glass warranty only applicable to first point of delivery.

**⚠ WARNING:** This product can expose you to chemicals, including Urethane (Ethyl Carbamate), which are known to the State of California to cause cancer and birth defects or other reproductive harm. For more information go to [www.P65Warnings.ca.gov](http://www.P65Warnings.ca.gov).