

"LT6R5" ERGONOMIC HYDRAULIC LIFT TABLES

16GA Stainless Steel Riser Top w/18GA Stainless Steel Fixed Legs & Undershelf

FEATURES:

- 16GA Stainless Steel Top w/5" Riser
- 18GA Fixed Stainless Steel Undershelf
- Hydraulic Lift System
- 32"-40" Adjustable Table Height
- 8" Stroke Lift System Cylinders
- Hand Crank Height Adjustment
- Foldable Hand Crank When Not In Use
- Adjustable Floor Glides

SPECIFICATIONS:

- Top: Stainless Steel Tops Are Tig Welded, Exposed Welds Are Polished To Match Adjacent Surface
- Top: 16GA Stainless Steel Type 300 Series
- Fixed Shelf: 18GA Stainless Steel
- Legs: Stainless Steel
- Feet: Adjustable Floor Glides

CERTIFICATIONS:



LT6R5-3048SSW

ACCESSORIES

DESCRIPTION

Casters (Add Suffix "-C")

"LT6R5" ERGONOMIC HYDRAULIC LIFT TABLE W/ RISER

MODEL	SIZE (L X W X H)	WEIGHT (LBS)
LT6R5-3048SSW	48"x30"x32"-40"	255
LT6R5-3060SSW	60"x30"x32"-40"	275
LT6R5-3072SSW	72"x30"x32"-40"	296

ALL DIMENSIONS ARE TYPICAL. TOLERANCE +/- .500". JOHN BOOS & CO. RESERVES THE RIGHT TO CHANGE SPECIFICATIONS WITHOUT NOTICE.

DETAILED SPECIFICATIONS

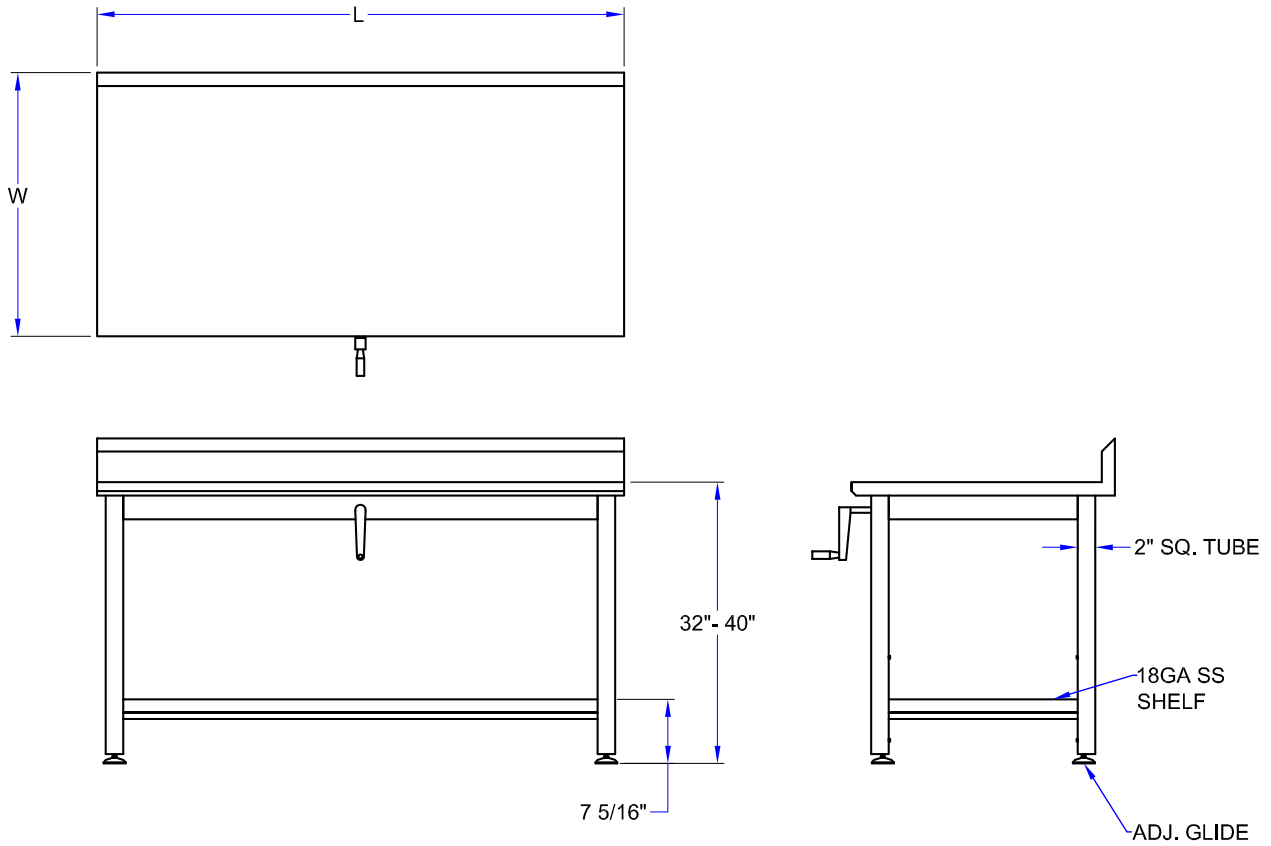

"LT6R5" ERGONOMIC HYDRAULIC LIFT TABLE W/ RISER

MODEL	SIZE (L X W X H)	WEIGHT (LBS)
LT6R5-3048SSW	48"x30"x32"-40"	255
LT6R5-3060SSW	60"x30"x32"-40"	275
LT6R5-3072SSW	72"x30"x32"-40"	296

ALL DIMENSIONS ARE TYPICAL. TOLERANCE +/- .500". JOHN BOOS & CO. RESERVES THE RIGHT TO CHANGE SPECIFICATIONS WITHOUT NOTICE.