



# BEVERAGE-AIR

Project: _____	AIA#
Item: _____	
Location: _____	SIS#
Approved: _____	

UCR24HC UNDERCOUNTER REFRIGERATOR

## SHALLOW DEPTH UNDERCOUNTER REFRIGERATOR

UCR24HC Solid Door Refrigerator  
Hydrocarbon Series

MODEL:  
UCR24HC



Note: Shown with optional full electronic control

**7 Year Parts/Labor Warranty**  
**7 Year Compressor Warranty**

### CABINET CONSTRUCTION

- Stainless steel front, sides, top, door and grille (galvanized steel back & bottom)
- Interior liner is made of corrosion resistant aluminum
- Mechanical control
- Undercounter feature a 1/2" thick sub-top
- Interior thermometer
- Self-closing door with 120° stay-open feature, on cartridge style hinges
- Magnetic gasket attached to each door for positive seal
- 6" Casters, two (2) with brakes standard
- Two (2) epoxy-coated steel wire shelves
- Field-reversible door

### OPTIONS & ACCESSORIES

- Stainless steel back
- Stainless steel interior
- Full electronic control\*
- Additional shelves
- Shelf clips
- Right or left hinged door
- Lock
- Wire shelf divider
- 3" Casters
- 6" Legs (stainless steel, black or seismic/flange)
- Low profile casters
- Roller kit
- Remote option\* (see note on back on page)

### REFRIGERATION SYSTEM

- Uses environmentally friendly, energy efficient R290 refrigerant, and meets all regulatory requirements for CARB, SNAP, DOE & more
- Adaptive defrost
- Epoxy coated evaporator coil
- Refrigerators capable of maintaining product temperature between 36°F and 38°F



Please verify qualifying units by visiting:  
[www.energystar.gov/cfs](http://www.energystar.gov/cfs)

3779 Champion Blvd., Winston-Salem, NC 27105  
1-888-845-9800 Fax: 1-336-245-6453  
Beverage-Air.com Sales@bevair.com



# BEVERAGE-AIR

MODEL	UCR24HC
<b>EXTERNAL DIMENSIONAL DATA</b>	
Width Overall	24"
Depth Overall with Handle & Bumper	30"
Height Overall with 6" Casters	34 5/8"
Number of Doors	1
Depth with Door Open 90°	50 1/4"
Door Opening	19 5/8" x 21 5/8"
<b>INTERNAL DIMENSIONAL DATA</b>	
NET Capacity (cubic ft.)	4.48
Internal Width Overall (in)	20"
Internal Depth Overall (in)	18"
Internal Height Overall (in)	23"
Number of Shelves	2
<b>ELECTRICAL DATA</b>	
Full Load Amperes	2.0
<b>REFRIGERATION DATA</b>	
Horsepower	1/10
Capacity (BTU/Hr)	1110
Heat Rejection (BTU/Hr)	1665
Charge (lbs/grams/ounces)	0.1323 / 60 / 2.12
<b>SHIPPING DATA</b>	
Gross Weight - Crated	164 lbs
Height - Crated	40"
Width - Crated	30"
Depth - Crated	32"

\*NOTE: Remote units are field wired and come with 6" legs. Refrigerant must be specified at time of order.

We reserve the right to change specifications and product design without notice. Such revisions do not entitle the buyer to corresponding changes, improvements, additions or replacements for previously purchased equipment. Dimensional tolerances +/- 1/4". Metric dimensions (MM).

## Undercounter Refrigerator - Shallow Depth Model: UCR24HC

### Model Views

Required Clearance: 3" Bottom & 2" Rear

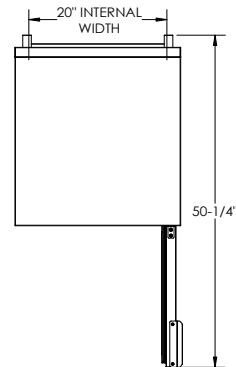

### PLAN VIEW

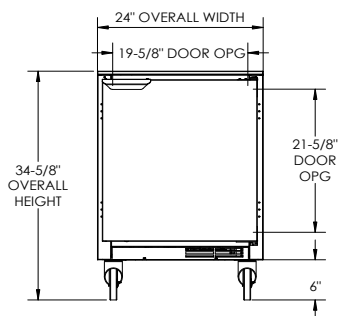

### ELEVATION VIEW

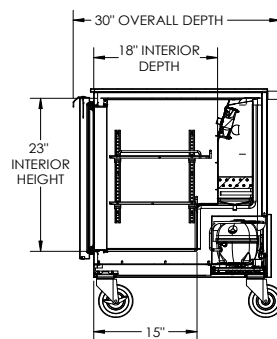

### SIDE VIEW

### ELECTRICAL CONNECTION



115/60/1  
NEMA 5-15P

Unit pre-wired at factory and include 8' long cord and plug set.

