

Special Features:

- ✓ Durable Aluminum Construction
- ✓ Locking Door With Stainless Steel Latch
- ✓ 40 Full-Size 18"x26" Sheet Pan Capacity
- ✓ 1.5" Spacing Between Pan Runners
- ✓ End Load Style Rack
- ✓ Aluminum Welded Channel
- ✓ Includes (4) 5" Polyurethane Wheel Casters with Swivel Top Plates (4 with Locks)
- ✓ 5 Mesh Covered Venting Holes
- ✓ Bumpers on All 4 Corners at the Bottom
- ✓ Handles on 2 Sides
- ✓ Top Latch

About Empura Bun Pan Racks:

Empura bun pan racks are an economical option for updating or expanding your baking prep and cooling areas. With their durable aluminum construction, sturdy shelf rails, and high pan and weight capacity, these bun pan racks are indispensable in the kitchen. They provide reliable stability and support for any task, ensuring your staff can work efficiently and effectively.

TECHNICAL SPECS

Model #	E-EBR1840
Overall Width	21"
Overall Depth	27"
Overall Height	68"
Full / Half Pan Capacity	40 Full Pans
Caster Type	Polyurethane Wheel Casters
Number of Casters	4
Number of Locking Casters	4
Caster Height	6.19"
Caster Wheel Diameter	5"
Caster Wheel Width	1.25"
Caster Wheel Material	Polyurethane HI-TECH
Construction Material	Aluminum
Rack Type / Style	Enclosed
Pan Shelf Spacing	1.5"
Loading Method	End Load
Venting Holes	5, Mesh Covered
Caster Brake Type	Top Brake

E-EBR1840

Unit Drawings

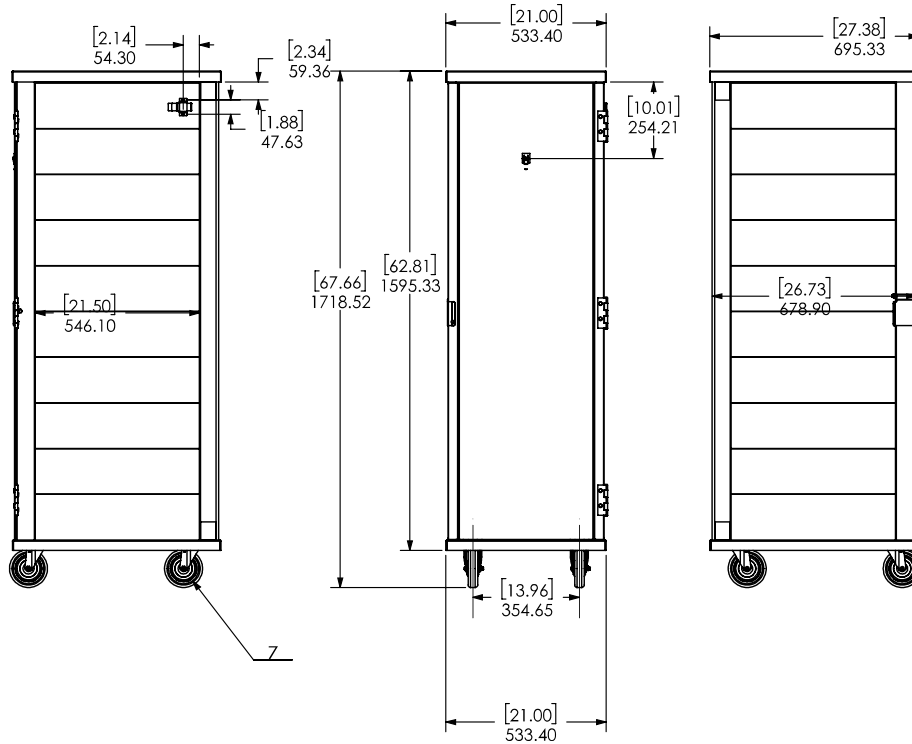

Caster Rendering & Measurements

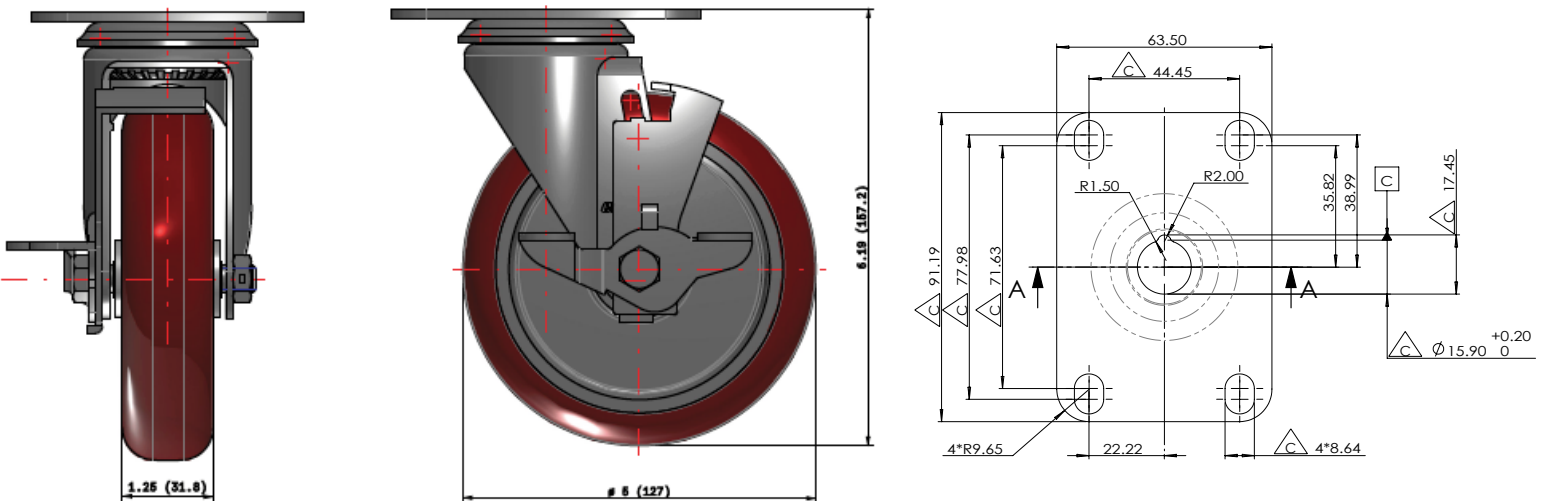

Intended For Commercial Use Only. Empura assumes no liability for component failure, factory defects or any other damages for units installed in non-commercial foodservice or residential applications.

Attention CA Residents: This product can expose you to chemicals including lead, which are known to the State of California to cause cancer, birth defects, or other reproductive harm. For more information, go to www.p65warnings.ca.gov.