

"ALMBR-W" MEAT BOAT RACKS

Aluminum - Wall Mount

FEATURES:

- Type 6063-T5 Aluminum
- Square Tube Frame, Slatted Shelf, Back And Sides
- Wall Mount
- Standard With Paper Tray



ACCESSORIES

MODEL	DESCRIPTION
ALMBR-D	Aluminum Dividers

"ALMBR-W" MEAT BOAT RACKS

MODEL	SIZE (L X W)	# OF DRAWERS	PAPER HOLDER WIDTH (A)	WEIGHT (LBS)
ALMBR-4W	48"x20"	2	18	13
ALMBR-5W	60"x20"	2	24	15
ALMBR-6W	72"x20"	2	30	18
ALMBR-8W	96"x20"	3	24	21

ALL DIMENSIONS ARE TYPICAL. TOLERANCE +/- .500". JOHN BOOS & CO. RESERVES THE RIGHT TO CHANGE SPECIFICATIONS WITHOUT NOTICE.

DETAILED SPECIFICATIONS

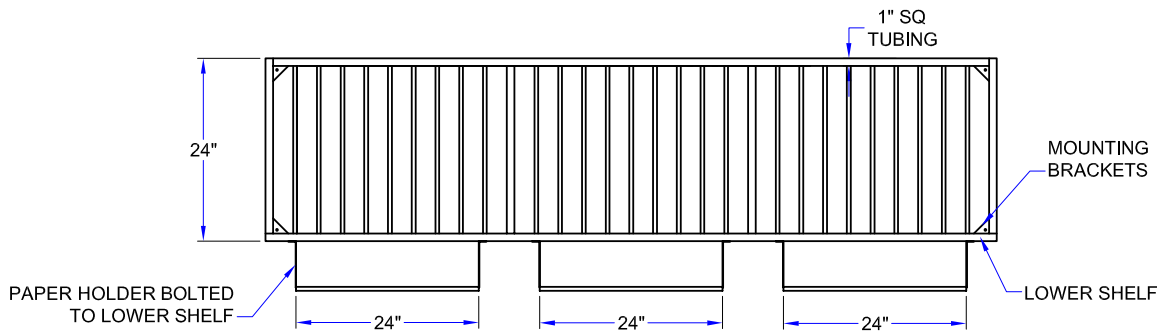
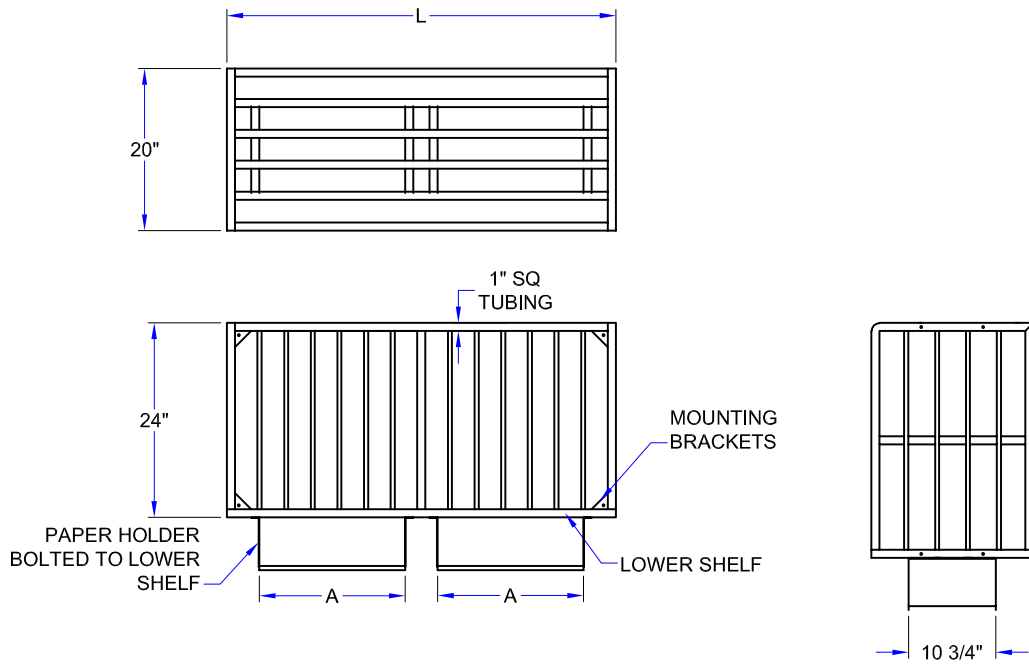

"ALMBR-W" MEAT BOAT RACKS

MODEL	SIZE (L X W)	# OF DRAWERS	PAPER HOLDER WIDTH (A)	WEIGHT (LBS)
ALMBR-4W	48"x20"	2	18	13
ALMBR-5W	60"x20"	2	24	15
ALMBR-6W	72"x20"	2	30	18
ALMBR-8W	96"x20"	3	24	21

ALL DIMENSIONS ARE TYPICAL. TOLERANCE +/- .500". JOHN BOOS & CO. RESERVES THE RIGHT TO CHANGE SPECIFICATIONS WITHOUT NOTICE.