



Project _____
 AIA # _____ SIS # _____
 Item # _____ Quantity _____ C.S.I. Section 114000

RMC SERIES MILK COOLER 16 CRATE CAPACITY MODELS



Model Shown - RMC49D4

STANDARD PRODUCT FEATURES

- Energy Efficient Refrigeration System, Using R290 Refrigerant
- Thermostatic Expansion Valve Metering Device
- Stainless Steel Exterior & Interior
- Electronic Control
- Top Mounted Removable Refrigeration System
- Forced Air Refrigeration System
- Accommodates (16) 13" x 13" Crate(s) or (8) 13" x 19" Crate(s)
- Single or Double Sided
- Low Access Point
- Sliding Lift Up & Down Door(s)
- Reinforced Cabinet Exterior Bottom
- Heavy Duty Dunnage Racks Protect Cabinet & Promote Airflow
- Durable Caster Rail System for Flexible Positioning
- Lockable Insulated Doors
- Metal Door Handles
- Magnetic Snap-In EZ-Clean Door Gasket(s)
- Floor Drain with Plug
- 9' Cord & Plug Attached
- Set of Four (4) 4" Factory Mounted Adjustable Casters



Models listed to the applicable UL, CSA and NSF standards by an approved NRTL. Consult the factory or unit data plate for additional information.

AVAILABLE CONFIGURATIONS

Single Access Models

RMC58S4 16 Crate 58" Length, 4" Casters

Double Access Models

RMC58D4 16 Crate 58" Length, 4" Casters

ACCESSORIES & OPTIONS (*field installed)

- Set of (4) 6" Adjustable Casters
- MCACC-BUMPER, Bumper Corner Guard Kit (4)
- RMCACC-SYS34, Milk Cooler Refrigeration System Replacement (Compatible only with models using R290 Refrigerant)

Approved by _____ Date _____ Approved by _____ Date _____

MODELS

Single Access Model: RMC58S4

Double Access Model: RMC58D4

Single Access Models

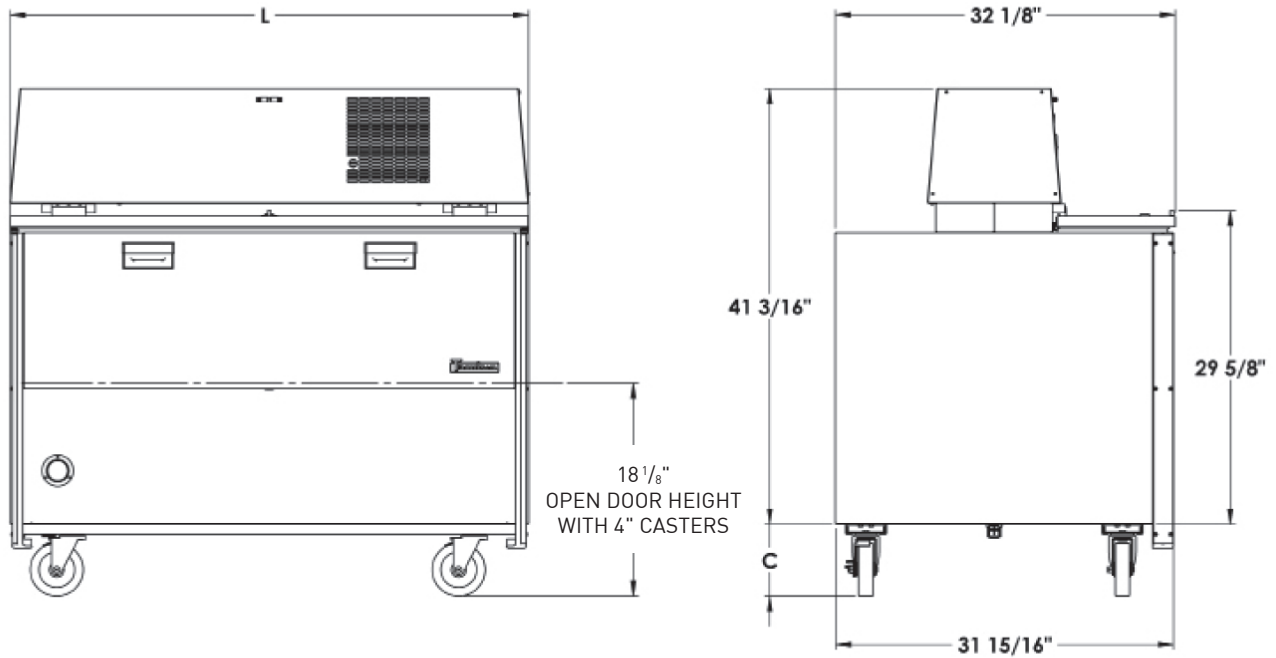

Double Access Models

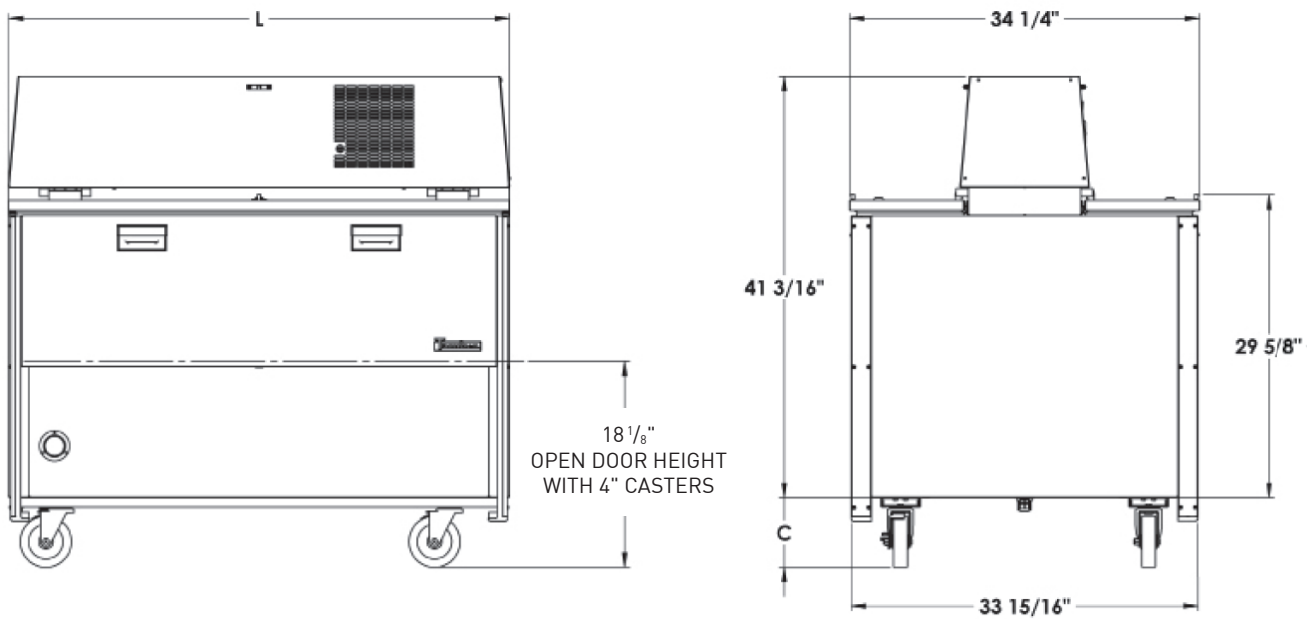



MODELS

Single Access Models: RMC58S4
Double Access Models: RMC58D4

EQUIPMENT SPECIFICATIONS

MODELS	RMC58
DIMENSIONAL DATA	
Net Crate Capacity 13 x 13 in. ¹	16
Net Crate Capacity 13 x 19 in. ¹	10
Length (L)-Overall in.	58 (147.3 cm)
Depth-Single Cabinet Only in.	32 1/8 (81.6 cm)
Depth-Double Cabinet Only in.	34 1/4 (87 cm)
Height-Overall on 4" Casters	46 (116.8 cm)
Net Weight uncrated lbs. (kg)	568 (258)
ELECTRICAL DATA (NEMA 5-15P attached)	
Voltage	115/60/1
Single & Dual Access Full Load Amperes kWh/Day ²	3.2 2.36 kWh/Day
Single Access Cabinet Volume	21.18
Double Access Cabinet Volume	22.53
REFRIGERATION DATA	
Refrigerant	R-290
Refrigerant Amount oz.	2.5 (70.9 g)
BTU/HR ³ H.P.	2100 1/4 H.P.

NOTE:

- * Figures in parentheses reflect metric equivalents.
- 1. Net Capacity cu. ft.
- 2. kWh/Day = Kilowatt usage per 24 hours.
- 3. Based on a 90°F ambient and 20°F evaporator.

When ordering please specify: Voltage, Hinging, and Options.

Equipped with one NEMA 5-15P Plug



CONSTRUCTION, HARDWARE, INSULATION

Cabinet exterior and interior is constructed of stainless steel. Interior sides, back and front are also stainless steel. The exterior cabinet bottom is constructed of stainless steel.

Gasket profile and material simplify cleaning and increase overall gasket life.

Both the cabinet and doors are insulated with non-CFC, foamed in place polyurethane.

DOOR/ACCESS

Front sliding protects gasket(s). Lockable lift up top access door.

REFRIGERATION SYSTEM

A balanced, top mounted side and front and rear breathing, refrigeration system using environmentally friendly, low GWP R-290 refrigerant is provided. It features an air-cooled hermetic compressor, thermostatic expansion valve metering device, and a forced air evaporator coil. An 9' cord and plug is provided. Standard operating temperature is 34° to 38°F (1.1° to 3.3°C).

CONTROLLER

An electronic digital control is supplied standard. It includes a 3-Digit LED display, and a Fahrenheit or Celsius temperature scale display capability.

INTERIOR/DUNNAGE RACKS

Heavy duty removable dunnage racks protect cabinet and promote airflow.

WARRANTIES

Both a six year parts and labor warranty and seven year compressor parts warranty.