



Project \_\_\_\_\_  
 AIA # \_\_\_\_\_ SIS # \_\_\_\_\_  
 Item # \_\_\_\_\_ Quantity \_\_\_\_\_ C.S.I. Section 114000

## R/A Series

26" Wide Pass-Thru Refrigerator  
 Solid Door, 32" Deep, Self-Contained



### STANDARD PRODUCT FEATURES

- Traulsen's Smart Control™ with LED Display
- Stainless Steel Exterior & Interior
- Balanced, Self-Contained Refrigeration System Using R-290
- Variable Speed Compressor Adapts to Work Environment
- Full or Half-Height Stainless Steel Doors with Lock(s)
- Anti-Condensate Door Perimeter Heater
- Self-Closing Doors with Stay Open Feature at 120 Degrees
- Standard Door Hinging F & R: 132NP = Left/Right (other hingsings available)
- LED Lights with Exterior Switch
- Stainless Steel Breaker Caps
- (3) Adjustable, Coated Wire Shelves Per Section, Supported on Shelf Pins (factory-installed)
- Automatic Non-Electric Condensate Evaporator
- Magnetic Snap-In EZ-Clean™ Door Gaskets
- Gasket-Protecting Door Liner
- Thermostatic Expansion Valve Metering Device
- Stainless Steel One-Piece Louver Assembly
- 9' Cord & Plug Attached
- Set of (4) 6" High Adjustable Stainless Steel Legs

### ACCESSORIES & OPTIONS

- SmartConnect™ Monitoring App with Wi-Fi Connectivity
- Accommodates EZ-Clean™ Tray Racks
- #1 Type Trayslides to Accommodate (1) 18" x 26" or (2) 14" x 18" Pans
- #4 Type Trayslides to Accommodate 18 to 19 Levels for 18" x 26" Pans
- Universal Type Tray Slides to Accommodate (1) 18" x 26" or (2) 14" x 18" Sheet Pans, or (2) 12" x 20" Steam Table Pans
- Additional Coated Wire or Optional Stainless Steel Shelves
- EZ-Open™ Foot Pedal (full height doors only)
- Locking Hasps (padlocks supplied by others)
- Optional 220/50/1 or 208-230/115/60/1 Voltages
- Kool Klad™ Exterior Laminate Decor
- Set of (4) 4 1/8" or 6" High Casters in Lieu of Legs
- Other Support Options: 4 1/2" High Base or 6" High Kickplate (with standard legs)
- Clear Glass Doors in Place of Solid Doors



Models listed to the applicable UL, CSA and NSF standards by an approved NRTL. Consult the factory or unit data plate for additional information.

### AVAILABLE CONFIGURATIONS

<b>R-Series Models</b>	<b>Door(s)</b>
RHT132NPUT-FHS	Full Height Solid
RHT132NPUT-HHS	Half Height Solid
<b>A-Series Models</b>	<b>Door(s)</b>
AHT132NPUT-FHS	Full Height Solid
AHT132NPUT-HHS	Half Height Solid

**\*Remote application available,  
 see form TR35837 for details.**

- GUARANTEED FOR LIFE CAM-LIFT HINGES
- GUARANTEED FOR LIFE HORIZONTAL WORK FLOW DOOR HANDLES (SOLID DOORS ONLY)



ENERGY STAR® Listed Commercial Refrigerator  
 For full listing visit [energystar.gov](http://energystar.gov)

Approved by \_\_\_\_\_ Date \_\_\_\_\_ Approved by \_\_\_\_\_ Date \_\_\_\_\_

**MODELS:**

RHT132NPUT-HHS, RHT132NPUT-FHS  
AHT132NPUT-HHS, AHT132NPUT-FHS

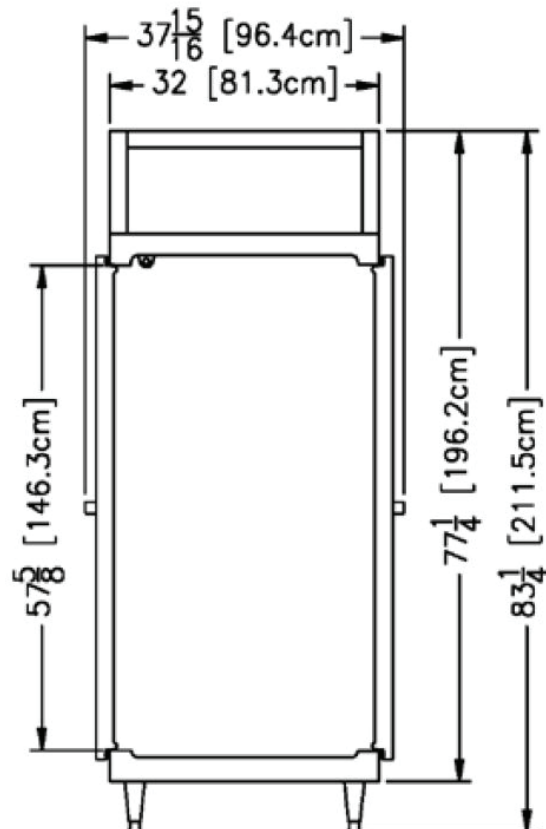
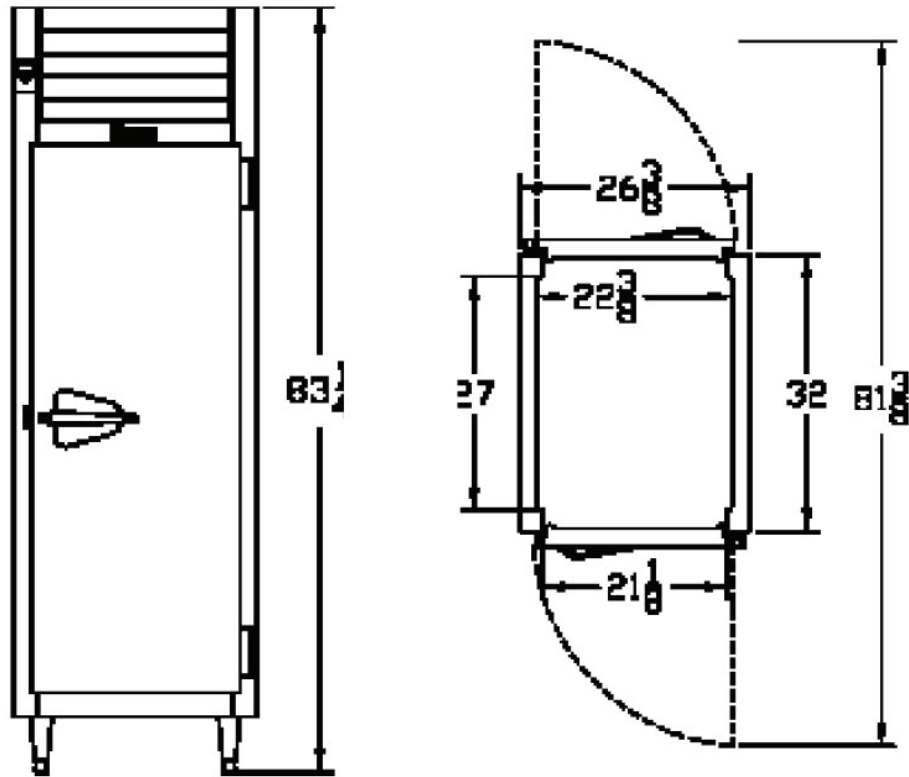

> CAD and/or Revit Files Available

<https://traulsen.klccad.com/>



# R/A Series

26" Wide Pass-Thru Refrigerator  
Solid Door, 32" Deep, Self-Contained

## MODELS:

RHT132NPUT-HHS, RHT132NPUT-FHS  
AHT132NPUT-HHS, AHT132NPUT-FHS

## EQUIPMENT SPECIFICATIONS

MODELS	R/AHT132NPUT
<b>DIMENSIONAL DATA</b>	
Net capacity cu. ft.	22.56 (638.8 cu l)
Length - overall in.	26 <sup>3</sup> / <sub>8</sub> (66.9 cm)
Depth - overall in.	37 <sup>15</sup> / <sub>16</sub> (96.4 cm)
Depth - over body in.	32 (81.3 cm)
Depth - door open 90° in.	81 <sup>3</sup> / <sub>8</sub> (206.7 cm)
Clear door width in.	21 <sup>1</sup> / <sub>8</sub> (53.6 cm)
Clear half-door height in.	27 <sup>1</sup> / <sub>2</sub> (69.9 cm)
Clear full-door height in.	57 <sup>5</sup> / <sub>8</sub> (146.3 cm)
Height - overall on 6" legs <sup>2</sup>	83 <sup>1</sup> / <sub>4</sub> (211.5 cm)
No. Standard Shelves	3
Shelf area sq. ft. <sup>3</sup>	12.11 (1.13 sq. m)
<b>ELECTRICAL DATA</b>	
Voltage   Plug	115/60/1   NEMA 5-15P
Full Load Amperes   kWh/24HR <sup>4</sup>	7.6   2.36 kWh/Day
<b>REFRIGERATION DATA</b>	
Refrigerant	R-290
Refrigerant Charge Amount oz.	4.8 (136 g)
BTU/HR   H.P. <sup>1</sup>	2875   ½ HP
<b>SHIPPING DATA</b>	
Length - Crated in.	48 (121.9 cm)
Width - Crated in.	42 (106.7 cm)
Height - Crated in.	85 (215.9 cm)
Volume - Crated cu. ft.	99.17 (2808.2 cu l)
Weight - Crated lbs.	494 (224.1 kg)

**NOTES:** Figures in parentheses reflect metric equivalents.

1. Based on a 90°F ambient and 20°F evaporator.
2. 12" Top clearance preferred for optimum performance & service access.
3. Area of standard shelf compliment only, does not include storage area of additional shelves or available on cabinet bottom.
4. MDEC = Maximum Daily Energy Consumption

### CONSTRUCTION, HARDWARE, INSULATION

The cabinet interior, exterior front, one piece sides & louver assembly are made from heavy-gauge stainless steel. The exterior top & bottom are made from heavy-gauge galvanized steel. Included is a set of four adjustable 6" stainless steel legs.

Doors have removable plug cylinder locks & guaranteed for life gravity action, self-closing glide hinges that stay open at 120 degrees. An external switch is included to activate interior LED lighting. The gasket design simplifies cleaning & enhances longevity. Anti-condensate heaters are located behind each door opening.

The unit has seamless, polished metal corners & guaranteed for life workflow door handles mounted horizontally over recess in door which limits protrusion from door face into aiseways. The cabinet is insulated with high density, non-CFC, foamed in place polyurethane.

### SELF-CONTAINED REFRIGERATION SYSTEM

The unit uses a top-mounted, balanced system located behind the one piece louver assembly. The R-290 refrigerant is environmentally friendly & low GWP. It features a finless StayClear™ condenser, thermostatic expansion valve, air-cooled hermetic variable speed compressor, plenum effect blower coil, large, high humidity evaporator coil outside the food zone & a top-mounted non-electric condensate evaporator. Operating temperatures are 34-38°F. A 9' cord and plug are provided.

### CONTROL

Traulsen's Smart Control™ features advanced control algorithms & sophisticated diagnostic capabilities to optimize performance. Utilizing smart sensors, it adapts the operation of the refrigeration system to a variety of environments & usage patterns. The Smart Control™ also offers a complete set of visual alarms designed to alert the user to critical events such as power outages or a prolonged door opening. In the event of an alarm, a dedicated Alarm LED will illuminate, informing the user of the critical event and duration.

### INTERIOR

The interior includes three factory installed pin-mounted, full-width coated wire shelves per section with no large gaps. Each shelf can support up to 225 lbs. Factory installed optional trayslides may be purchased in combination with, or in lieu of these.

### WARRANTY

Both a six year parts & labor warranty and a seven year compressor warranty [self-contained models only] are provided standard.

When ordering please specify: Voltage, Hinging, and Options

Equipped with one NEMA 5-15P Plug



CONTINUED PRODUCT DEVELOPMENT MAY NECESSITATE SPECIFICATION CHANGES WITHOUT NOTICE.