



SPEC SHEET

KoolMore 48 in. Commercial Chef Base Refrigerator Storage Cabinet for Cold Foods

SKU: KM-BR-482D

FEATURES

- Chef-Based Refrigerator Cabinet
- Digital Temperature Control
- Stainless-Steel Finish
- Automatic Defrost
- Temperature Range: 33-40°F
- ETL Listed for Safety and Sanitation



CLOSE UP IMAGES



TECHNICAL SPECS

Dimensions

Depth	48.3
Width	32.1
Height	25.9
Interior Depth	22.5
Interior Width	36.6
Interior Height	15.7
Shelf Width	NA
Shelf Depth	NA
Depth Including Handles	32.1
Depth Excluding Handles	32.1
Depth Less Door	32.1
Depth With Door Open 90 Degrees	53.6
Power Cord Length	98.5

Capacity

Weight	202
Gross Cubic Feet	9.3
Net Capacity Cu. Ft.	8.5
Individual Drawer Capacity	88
Top Capacity	792

Features & Material

Door Style	Drawer
Number Of Drawers	2
Top Material	SUS 304
Defrost Type	Automatic
Refrigerant Type	R290
Temperature Control Type	Digital
Ambient Temperature Range	90F
Temperature Range	33-40 F
Casters	4
Top Thickness	1.8
Top Style	Marine Edge
Interior Material	SS 201
Exterior Material	SS 430

Electric Data & Certifications

Amps	4.32
Phase	1
Plug Type	NEMA 5-15P
Voltage	115
Hertz	60
Wattage	343
Horsepower	0.4
Certifications	ETL Listed for Safety and Sanitation

Plan View

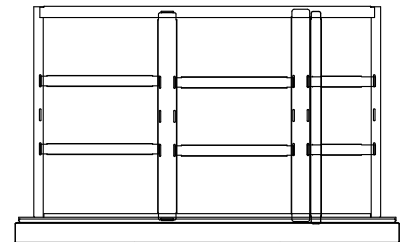
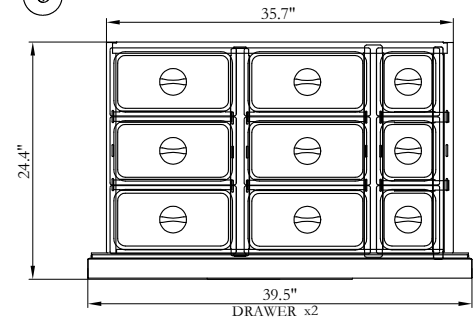
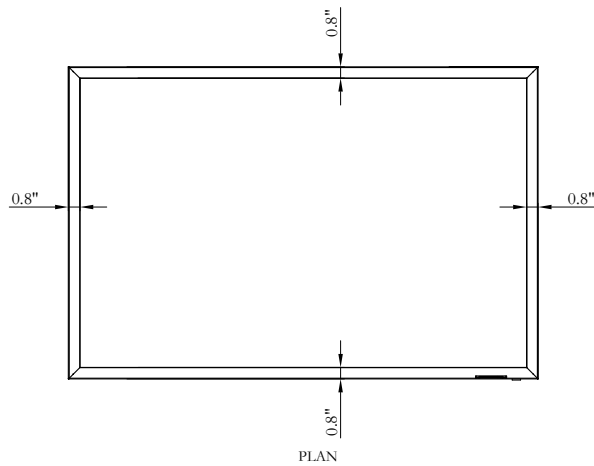
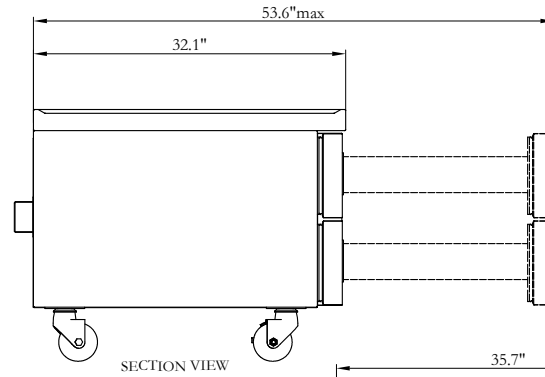
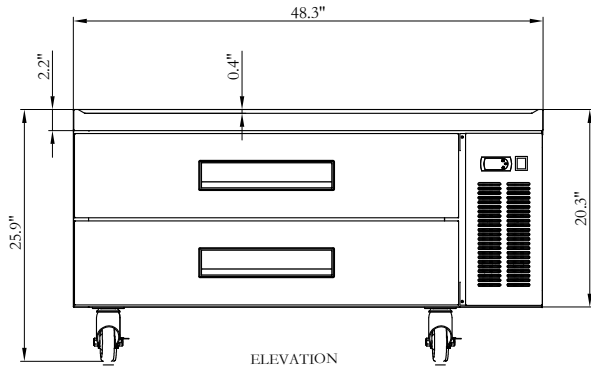

CERTIFICATIONS



Intertek



Intertek



706 Eastern Parkway STE 1G, Brooklyn NY 11213
718-576-6342
info@koolmore.com