

# FORCED AIR MILK COOLERS

## Model: MC3ND

Natural Refrigerant R-290 Model

### 34" Forced Air Milk Cooler Dual Access



ENERGY STAR® Qualified Commercial Refrigerator

White painted steel exterior, stainless steel top and door, heavy-duty stainless steel lid(s), door hinges and latches, galvanized steel interior with reinforced stainless steel floor. **Designed to keep milk cold during serving.**



## Options and Accessories

(upcharge and lead times may apply)

Stainless steel exterior	Floor foot pedal lock
Stainless steel interior	Color laminate
Wrap around bumpers	Corner bumpers

Consult factory for other model configurations, options and accessories.

**Continental**  
Refrigerator



Project Name:

Model Specified:

Location:

Item No:

Quantity:

AIA #:

SIS #:

## Standard Model Features

### REFRIGERATION SYSTEM

Forced air, performance rated refrigeration system

Natural, environmentally safe, high efficiency R-290 refrigerant<sup>1</sup>

Built-in, electric condensate evaporator

Easily serviceable, bottom mounted condensing unit

### CABINET ARCHITECTURE

2" high density, non-CFC polyurethane foamed-in-place insulation

REVISED: 7/20/2022

Snap in lids and door gaskets

Non-corrosive, heavy duty, epoxy coated steel wire floor racks

Cylinder keyed security locks

5" diameter swivel plate casters with front locking brakes

### MODEL FEATURES

Electronic controller with digital display & hi-low alarm

Floor drain

Unique forced air flow curtain

<sup>1</sup> R-290 refrigerant meets all federal and state regulatory requirements.

APPROVAL:

# Model Specifications

## DIMENSIONAL DATA

Net Capacity (cubic feet)	13.0 (368 cu l)
Crate Capacity (13" x 13" x 11")	8
Crate Capacity (19" x 13" x 11")	4
Width, Overall (inches)	34 (864 mm)
Depth, Overall (inches)	33 (838 mm)
Height, Overall (inches) (including 5" casters)	47 (1194 mm)

## REFRIGERANT DATA

Condensing Unit Size (H.P.)	1/4+
Capacity (BTU per hour)*	2080

## ELECTRICAL DATA

Voltage (International)	115/60/1 (220/50/1)
Total Amps (International)	5.7 (4.8)
10 ft. Cord/Plug [attached] (International)	Yes (No)

## SHIPPING DATA

Weight (pounds)	335 (152 kg)
Height - Crated (inches)	56 1/4 (1429 mm)
Width - Crated (inches)	43 1/4 (1099 mm)
Depth - Crated (inches)	36 1/2 (927 mm)

\* Rating @ +25°F evaporator, 90°F ambient  
Figures in parentheses reflect metric equivalents rounded to the nearest whole unit.



Equipped with one NEMA-5-15P Plug  
(varies by country)

# Model Plan Views

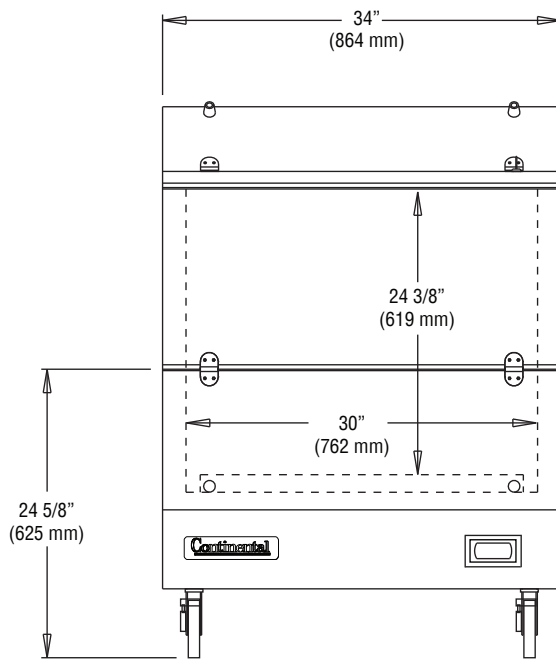

FRONT VIEW

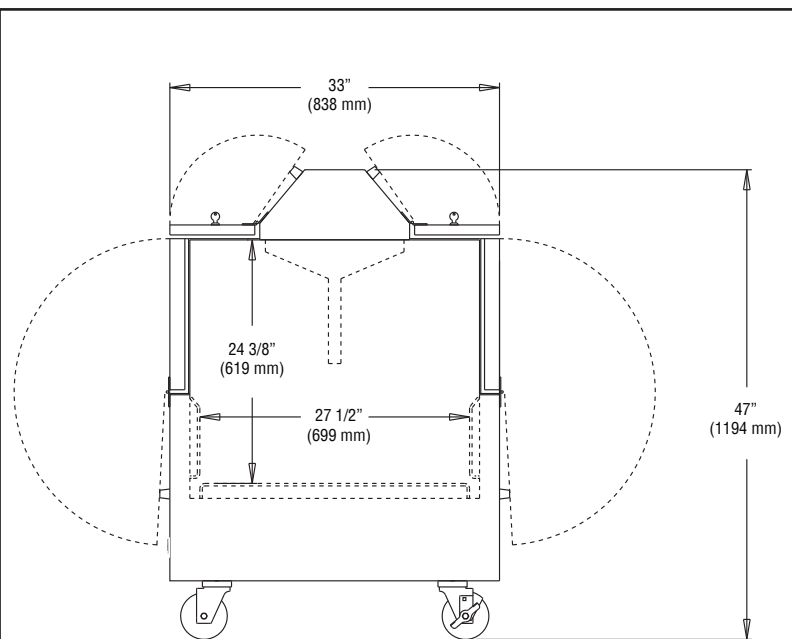

SIDE VIEW

**Continental**  
Refrigerator

Toll-Free: 800-523-7138  
Phone: 215-244-1400  
Fax: 215-244-9579

539 Dunksferry Road  
Bensalem, PA 19020  
[www.continentalrefrigerator.com](http://www.continentalrefrigerator.com)

Due to our continued efforts in developing innovative products, specifications subject to change without notice.



PROUDLY  
DESIGNED & ASSEMBLED  
IN THE U.S.A.

Intertek

© Copyright 2021. Continental Refrigerator.  
A Division of National Refrigeration & Air Conditioning Products, Inc.

REVISED: 5/9/24