

# EUROPA™

by **VERSA-GARD®**

# VPEC

Protected by US Patent 7,784,398

## Full Service Protector

### FINISH:

- Clear Anodized Aluminum
  - Powder Coat:
    - Black
    - Silver
- RAL# \_\_\_\_\_

### GLASS (Clear Tempered):

- 1/4" Bent - Std
- Frosted

### OPTIONS (\*):

- End Panel - LT
- End Panel - RT

(\* ) Not all options available on all models. Contact Factory for specific information. For Mounting Options, see Mounting Specification Sheet

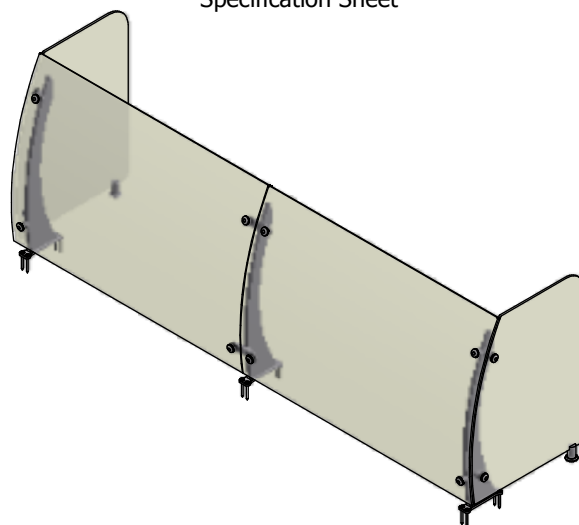
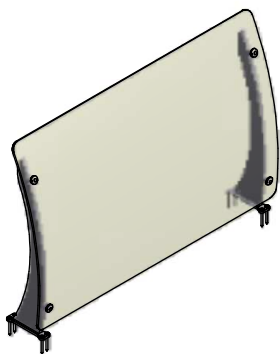

### NSF/ANSI 2 - 2010 Standards Requirements:

This language is copied with permission of NSF International

- 5.35.11 Food Shields for use on cooking and/or carving station operations**
- 5.35.11.1 Shields for use on a cooking and/or carving station shall include a vertical barrier to a minimum height of 60 inches above the finished floor.
- 5.35.11.2 Maximum vertical distance from the bottom edge of the shield and counter top shall be 6 inches
- 5.35.11.3 Minimum horizontal distance between the front inside edge of displayed food and front (customer side) face of shield shall be 3/4 of the vertical distance (.75 x 6" = 4") of 5.35.11.2
- 5.35.12 Food Shields for use on cafeteria counters**
- 5.35.12.1 The sum of a shield's protected horizontal plane (X) and its protected vertical plane (Y) shall be greater than or equal to 32 inches. When (X) = 0, (Y) shall be a minimum of 60 inches from finished floor
- 5.35.12.2 Maximum distance from the bottom edge of the front vertical glass and counter top shall be 1.5 inches
- 5.35.12.3 Maximum distance between the vertical glass and horizontal glass is 3/4 inch
- 5.35.12.4 Minimum horizontal distance between the front inside edge of displayed food and the bottom leading edge of the shield s 1.5 inches
- 5.35.6 A vertical barrier (end shield) shall be provided at each end of a foodshield. The vertical barrier shall be a minimum of 18 inches deep (front to back) beginning at the bottom leading edge of the foodshield. The minimum height of the vertical barrier shall be equal to the overall height of the foodshield. The maximum distance from the bottom edge of the vertical barrier and counter top shall be 1.5 inches.
- 5.35.6.1 A foodshield intended to be installed a maximum of 3" (76mm) from a building wall perpendicular to the foodshield is exempt from the requirements of 5.35.6 provided that the height of the building wall is not lower than the overall height of the foodshield.

### SPECIFY COUNTER HEIGHT

- 34" High
- 36" High

(2) End Panels per unit unless otherwise specified. End panels are 1/4" clear tempered glass unless otherwise specified.

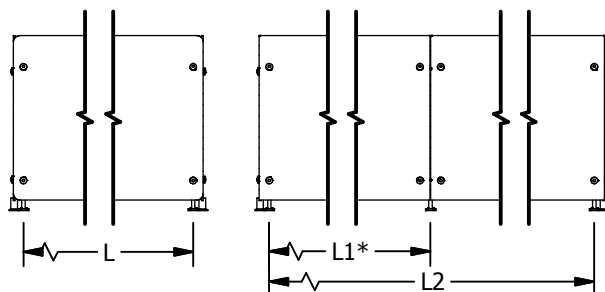

- Centerline Dimensions -  
L / L1 - 94" Max (1/4" Bent Glass)

\*\* 26" For 34" High Counter  
24" For 36" High Counter

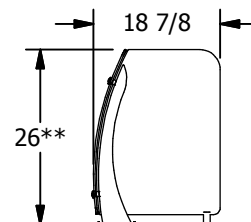

(\* - Middle support is centered unless L1 dimension is specified )



## CONCEALED MOUNT

**A** TO COUNTERTOP

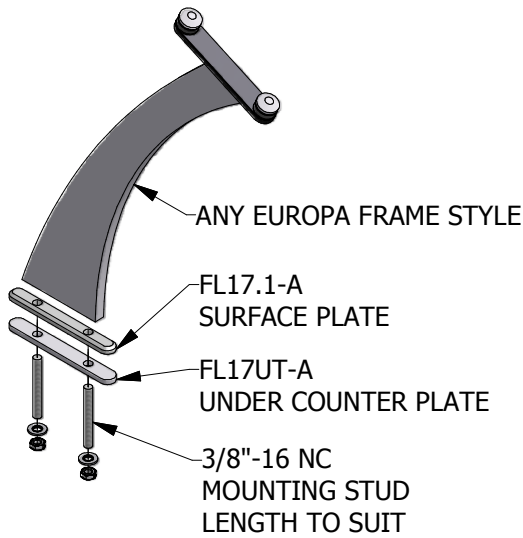

**B** TO DROP-IN FLANGE

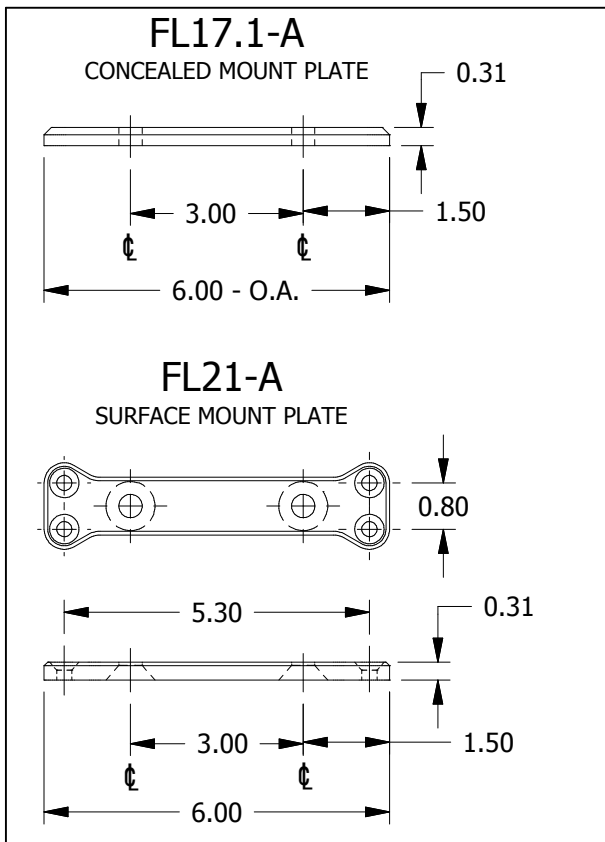
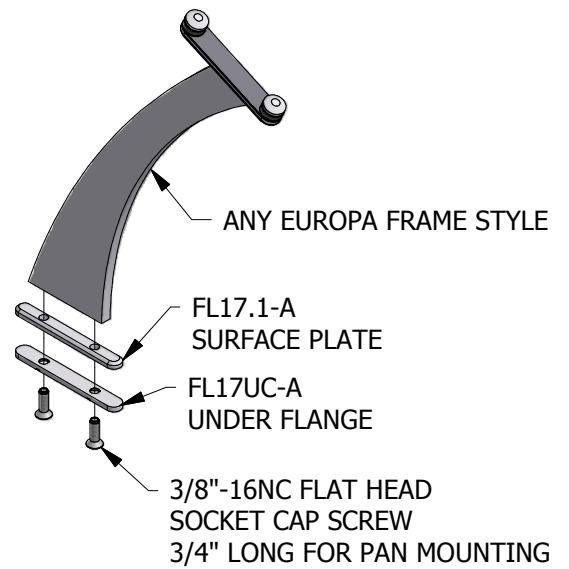

## SURFACE MOUNT



