

# EUROPA™

by VERSA-GARD®

# VGE5C-DS

Protected by US Patent 7,784,398

## Double Sided Self-Service Protector

### FINISH:

- Clear Anodized Aluminum
  - Powder Coat:
    - Black
    - Silver
- RAL# \_\_\_\_\_

### GLASS (Clear Tempered):

- 1/4" Bent Front - Std
- Frosted

### OPTIONS (\*):

- End Panel - LT
- End Panel - RT

(\* ) Not all options available on all models.  
Contact Factory for specific information.  
For Mounting Options, see Mounting  
Specification Sheet

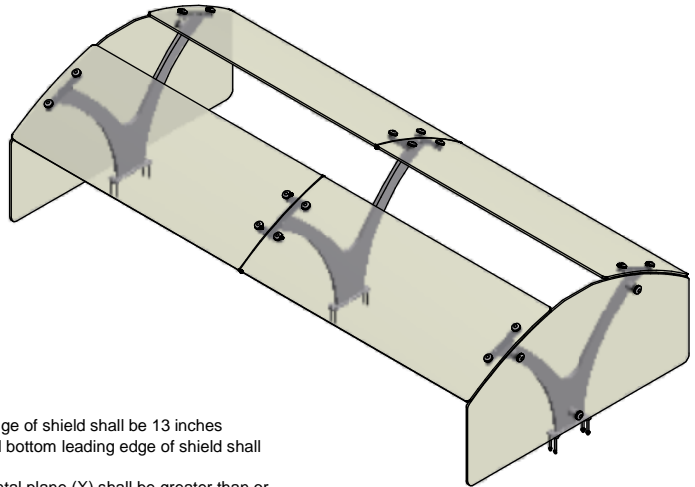
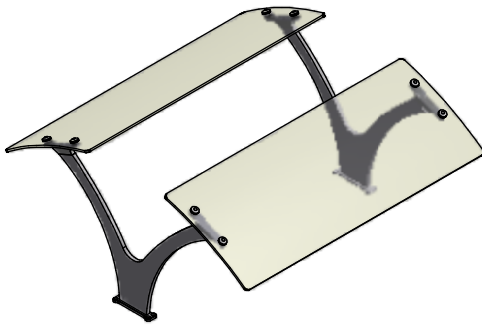

### NSF/ANSI 2 - 2010 Standards Requirements:

This language is copied with permission of NSF International

#### 5.35.7 Self service food shields

- 5.35.7.1 Maximum vertical distance between counter top and bottom leading edge of shield shall be 13 inches
- 5.35.7.2 Minimum horizontal distance between the front inside edge of food and bottom leading edge of shield shall be 3/4 of the Max. vertical distance of 5.35.7.1 (.75 x 13" = 9.75")
- 5.35.7.3 The sum of a shield's projected vertical plane (Y) and projected horizontal plane (X) shall be greater than or equal to 20 inches. Either (X) or (Y) may equal 0
- 5.35.7.5 Maximum horizontal distance between vertical, horizontal, and angled panels at post and framing member locations shall be 2 inches
- 5.35.7.10 Food shields for use on mobile buffet counters shall conform to 5.35.7
- 5.35.6 A vertical barrier (end shield) shall be provided at each end of a foodshield. The vertical barrier shall be a minimum of 18 inches deep (front to back) beginning at the bottom leading edge of the foodshield. The minimum height of the vertical barrier shall be equal to the overall height of the foodshield. The maximum distance from the bottom edge of the vertical barrier and counter top shall be 1.5 inches.
- 5.35.6.1 A foodshield intended to be installed a maximum of 3" (76mm) from a building wall perpendicular to the foodshield is exempt from the requirements of 5.35.6 provided that the height of the building wall is not lower than the overall height of the foodshield.

(2) End Panels per unit unless otherwise specified. End panels are 1/4" clear tempered glass unless otherwise specified.

- Centerline Dimensions -  
L / L1 - 66" Max (1/4" Bent Glass)

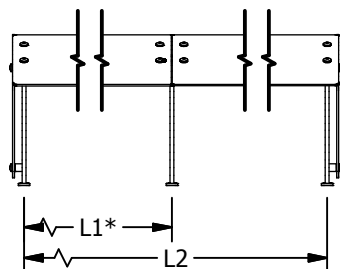
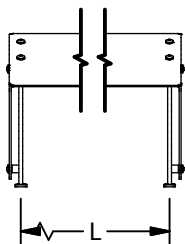

(\* - Middle support is centered unless L1 dimension is specified )

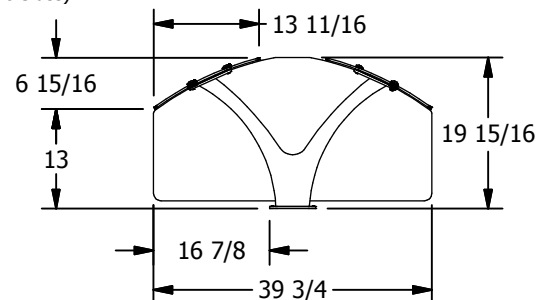

## CONCEALED MOUNT

**A** TO COUNTERTOP

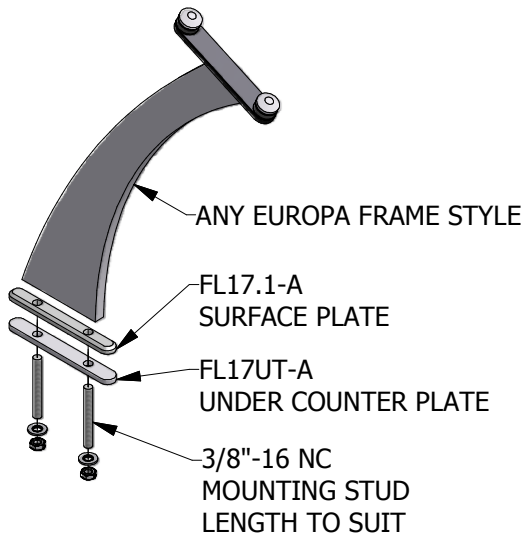

**B** TO DROP-IN FLANGE

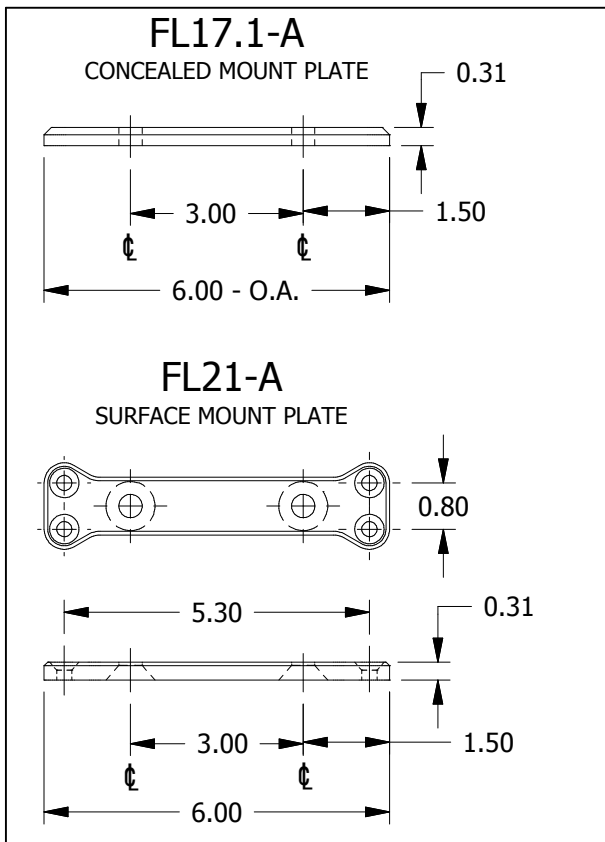
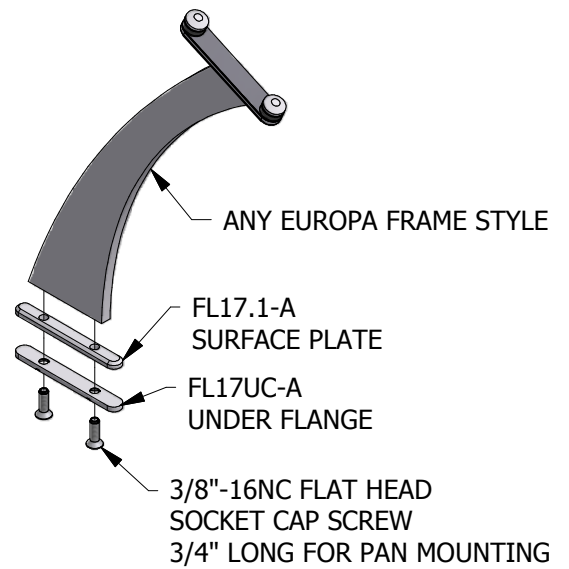

## SURFACE MOUNT



# EUROPA™

by **VERSA-GARD®**

# CONCEALED MOUNT DETAIL

Protected by US Patent 7,784,398

