

Empura®

EKB27F

Reach-In Bottom-Mount Freezer



Features

- CFC free refrigerant and foam insulation
- Electronic thermostat and digital LED temperature display for accurate control and easy reading
- 3 adjustable, heavy-duty epoxy coated wire shelves per door
- Condensate heating element built into condensate pan for efficient evaporation of excess water
- Freezer door frame has intergral factory installed heating element to eliminate condensation.
- Easy to mount 4" casters (lockable in front) are standard with all units
- Locking doors on all units. EKB27F door swing is field reversible
- Self-closing doors that remain open at 90 degrees
- Magnetic gasket can be replaced without any tools
- Exterior: 430 stainless steel, door & front panel: 202 stainless steel.
- Interior: 304 stainless steel
- Temperature: 0 to -10°F / -17 to -23°C
- Electrical: 115/60/1 with NEMA 5-15P plug

Warranty: 2-Years Parts & Labor, 5 Years on Compressor

MODEL	DOORS	EXT DIMENSIONS W x D x H	INT. DIMENSIONS W x D x H	AMPS	H.P.	SHIP WEIGHT
EKB27F	1	26.8 x 32.7 x 82.3	22.2 x 27.6 x 50.2	11	5/8	329 lbs

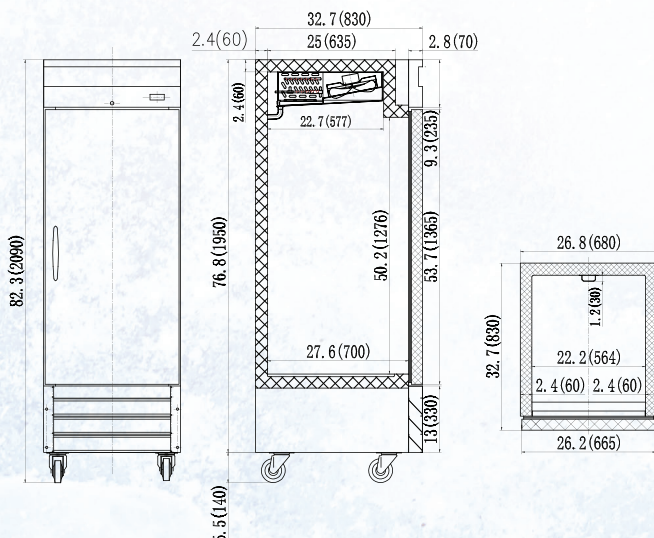

CERTIFIED TO ANSI/
NSF-7 STANDARDS