

Customer/Wholesaler:	Date:	Job Name:	Model Specified:	Quantity:
Contractor:		Architect/Engineer:		

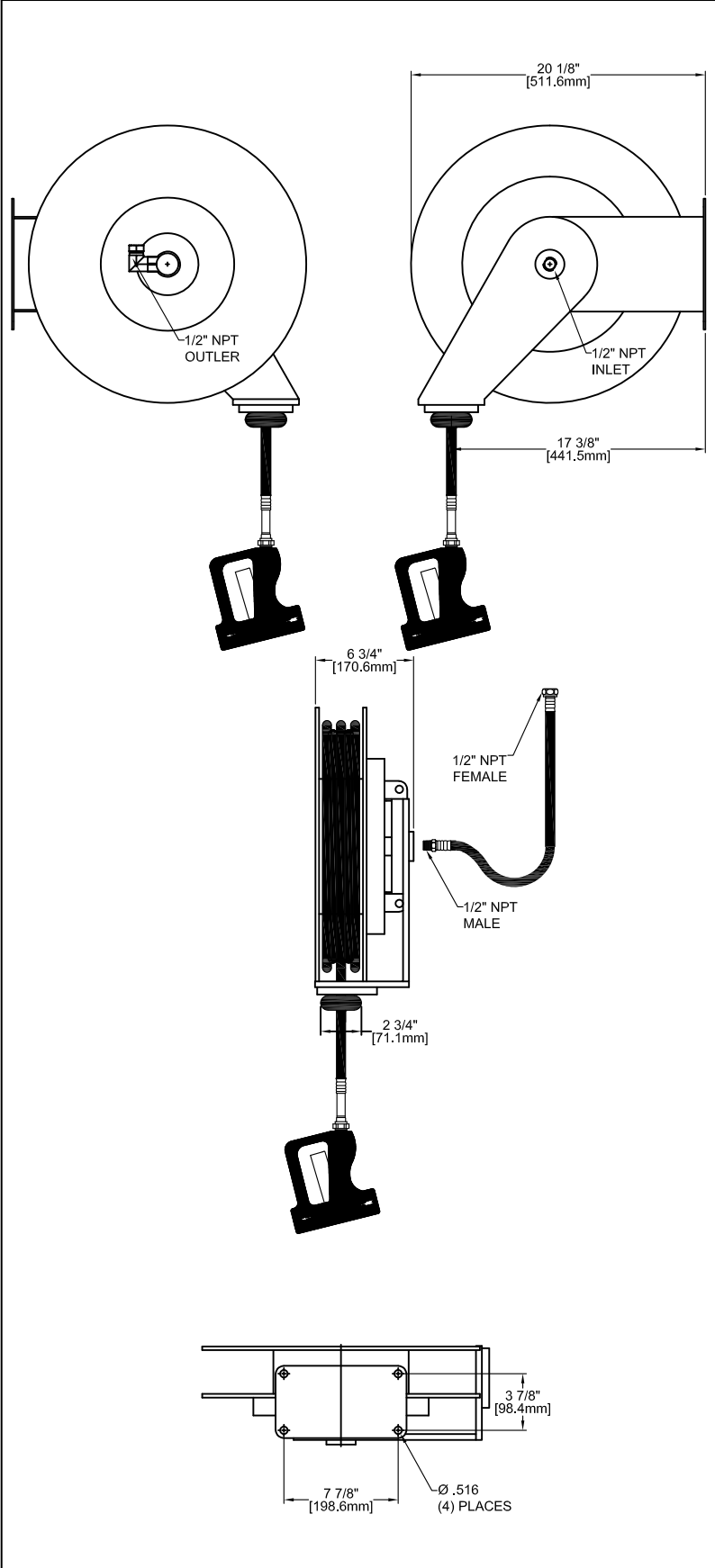

MODEL:

- 75396 35' LENGTH HOSE WITH SPRAY GUN
- 75397 50' LENGTH HOSE WITH SPRAY GUN

OPTIONS OR MODIFICATIONS:

- OTHER _____

FEATURES:

REEL RINSE

- * EXPOSED DESIGN
- * STAINLESS STEEL CONSTRUCTION
- * GUIDE ARM ADJUSTABLE TO 9 POSTIONS
- * RATCHET LOCK AND EASY TENSION ADJUST
- * STAINLESS STEEL OR BRASS FLUID PATH

HOSE

- * 35' OR 50' LENGTH REEL HOSE
- * 1/2" ID HIGH TEMPERATURE HOSE
- * 3-PLY FIBER REINFORCED
- * 24" LENGTH INLET HOSE
- * ADJUSTABLE BALL STOP

SPRAY GUN

- * STAINLESS STEEL CONSTRUCTION
- * WATERPROOF NYLON COVER
- * ERGONOMIC DESIGN
- * LOCKING TRIGGER MECHANISM
- * 7.0 GPM AT 80 PSI

SYSTEM LIMITS

- * TEMP: 40° F MIN. TO 160°F MAX.
- * PRESSURE 150 PSI MAX. STATIC

SHIPPING WEIGHT

- * 75396 - 55.0 LBS
- * 75397 - 60.0 LBS