

Fire Suppression MAX Induction Griddle Cooking Station, 5000W



Model #	Equipment	Cooking Type	Voltage	Amps	Plug Type
MCS-59-FPS-SP251G	SM-251-2CR	Cook/Hold, Griddle	208 AC	50	NEMA-6-50P

Description:

The Spring USA Fire Suppression MAX Induction Mobile Cooking Station (MCS) is the perfect way to add griddle induction cooking to your foodservice operation without additional hoods or duct work. An integrated UL300 Fire Suppression System and four-stage, self-contained filtration design eliminates the need for external ventilation, making it perfect for onsite cooking for hotels, restaurants, event spaces, ghost kitchens, grocery stores, convention centers, and more.

Agency Listings:

- ETL
- UL STD 197
- CSA C22.2 #109
- UL 300
- ANSI/UL 710B
- ANSI/NSF2
- Energy-star Certified*



Standard Warranty:

Limited 1 year warranty. Induction Ranges offer an overnight exchange warranty (continental US only). Visit springusa.com/warranty for details and exclusions.

Features:

- Buckeye fire suppression system
- Double hob MAX induction range offers more energy-efficient and precise heating
- Removable griddle overlay attachment
- 4-stage, self-contained air filtration system with LCD touchscreen menu & diagnostic reporting
- MAX induction system allows easy & quick replacement of ranges backed by standard overnight warranty
- Versa-Gard™ premium food shields
- Commercial-grade stainless steel construction
- Locking & swiveling casters, 800 lb rating
- Double towel bars & removable cutting board
- Expertly welded in the USA with fully sealed welds

*Induction range certification in progress

Construction & Performance Features:

Cabinet

- Integrated Buckeye BFR-5 UL300 Fire Suppression System
- Four-stage, self-contained recirculating air-filtration system for grease, smoke, and odor
- Low noise level, 55-58 dBA
- Only 170 CFM of make up air recommended
- Extremely efficient filtration captures emissions exceeding NFPA-96 and ANSI/UL710B requirements
- Touchscreen PLC controls air filtration and fire suppression systems
- Filter Life Extension Technology (FLEX) utilizes intelligent sensors and controls to optimize air flow and noise levels extending the life of filters up to 200% when compared to fixed flow systems
- Easy access to filters for convenient maintenance and replacement
- Solid Stainless Steel construction with standard P-LAM finishes included; premium panel P-LAM finishes available as an upgrade for front and sides to match adjacent millwork finishes
- Easy to clean, 5 mm thick, tempered glass cooktop and fully sealed welds
- Equipment plug & play design for easy repair or replacement of ranges
- Touchscreen PLC controls air filtration and fire suppression systems
- Requires 50 amp breaker to operate
- Additional requirement features available: hardwire alarm and earthquake lanyard

Induction Range (*Model #SM-251-2CR*)

- Includes one double MAX Induction range - 2500 W, 240 V, 10.4x2 amps, 60 Hz
- Premium performance with less than 1% failure rate
- Easy to clean, 5 mm thick, tempered glass cooktop
- Efficient, high-power air intake system
- Black, tempered glass faceplate
- Power on/off with power on/pan present indicator light
- Automatic Pan Recovery & SmartScan technology: over/under voltage protection and pan size and pan type recognition
- Cook/Temp mode touch pad with indicator lights
- Knob-set thermostat control with 20 temperature settings and digital LED display
- Detachable control box conveniently set into cart apron
- Cook mode levels 1-20 and temp mode range from 100°F-400°F



Griddle Overlay Attachment (*Model #SMG251-6*)

- 10 mm thick stainless steel cooking surface and hard chromium plating
- Larger surface area than other induction griddles on the market
- Attachment securely fits on top of the MAX Induction Reconfigurable Double Induction Range
- Inlay grease chute & pull-out drawer
- Removable handles for easy cleaning and changeover



Project _____

Model # _____ Quantity _____

Electrical Requirements:

Each Mobile Induction Cooking Station comes with an efficient Power Management System, powering the entire unit with a single receptacle, eliminating the need for multiple receptacles at various voltages. Integrated cooking equipment is powered by internal, dedicated 220V receptacle.

Model #	Voltage	Phase	Hertz	Watts	Amps	Plug
SM-251-2CR	208-240	1	60	2500 W x 2	10.4 x 2	NEMA 6-30P

Dimensions:

Type	Length	Width	Height	Weight
Product	59"	36.3"	51.3"	705 lb.
Shipping	72"	48"	60"	875 lb.

Notes & Conditions:

1. Ensure that you have dedicated power wherever you are planning to use your Mobile Induction Cooking Station. Refer to the manual for detailed instructions regarding operation.
2. Equipment will not power on without proper setting of fire suppression system or if safety protocols are engaged, see manual for more details.
3. Ensure the unit has proper ventilation at all times so it does not overheat.
4. The air filtration system is design exclusively for use with built-in induction ranges and cannot be used as a stand alone device or with other heating devices.
5. Induction ranges require use of ferrous metal, induction-ready cookware.
6. Spring USA Induction Servers and Induction Warmers/Ranges are designed to work together as a system. Optimal performance is achieved by using Spring USA components in conjunction with each other. As the first to offer such induction systems, Spring USA cannot warranty the performance of facsimile products offered by other companies.
7. Refer to individual specification sheets for the induction ranges, air filter system, or power management system for detailed information.

Key Dimensions:

FRONT VIEW

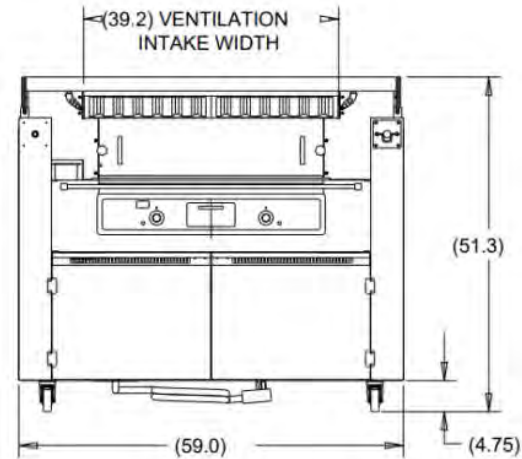

SIDE VIEW

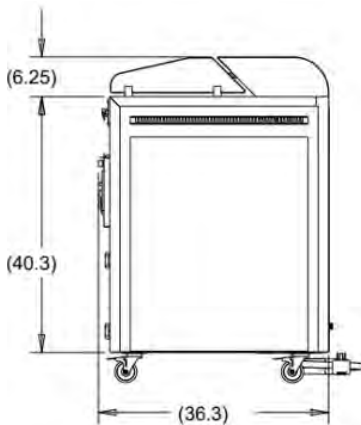

BACK VIEW

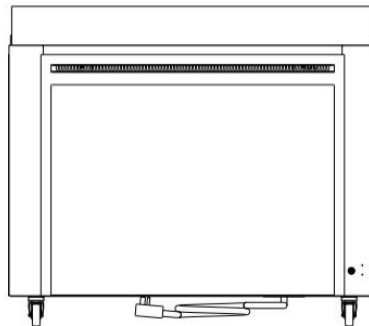

- Optional laminate panels in a selection of color choices

