

Insulated Multi-Functional Cookers

Electric, Low Lid Profile
Insulated for Safety™
10° Tilting, Leg Mounted
Made in USA

Skittle® Model SKL

Standard Features



Model SKL6-9
(with optional food pans)

- ◆ 304 stainless food contact zone with:
 - ◇ 304 stainless 1 ½" compression draw-off
- ◆ 304 stainless seam welded pan body with:
 - ◇ 10° tilting pan, 31" working height
 - ◇ Food pan holder under draw-off (except SK5)
 - ◇ Insulated sides and bottom
 - ◇ Tapered access rim
 - ◇ 240V, three phase (3Ø) standard
- ◆ Adjustable thermostat (175°F to 400°F)
- ◆ High limit safety thermostat
- ◆ Patented 304 stainless seam welded Capsule Lid with:
 - ◇ Variable position, actuator-assisted opening
 - ◇ Insulated sides & top
 - ◇ Adjustable steam vent
 - ◇ 304 stainless safety handle
 - ◇ "L" Lid condensate containment
- ◆ Cassette rack(s) for 12x20 food pans
- ◆ 304 stainless, seam welded component enclosure
- ◆ 304 stainless, seam welded tubular frame construction
- ◆ Single ball valve with 48" s/s flexible spray hose assembly
- ◆ Adjustable flanged feet

Legion equipment is built to comply with applicable standards for manufacturers. Approval agencies may include ASME, NSF, UL, ETL, AGA, CSA, CGA and others. Legion reserves the right of design improvement or modification as warranted.

Models and Capacities

Optional Features and Accessories

See price list for supplemental information regarding options

Model	2.5" Insert Pans	Cooking Baskets	Griddle Area (in. ²)	Kettle (Gals.)	Frying Oil (lbs.)	Oven Volume (ft. ³)
SKL3-5	3	2	351	7.6	35	2.8
SKL3-7	3	3	351	10.6	35	3.2
SKL3-9	3	3	351	13.7	35	3.6
SKL6-5	6	4	703	15.2	70	5.6
SKL6-7	6	6	703	21.3	70	6.4
SKL6-9	6	6	703	27.4	70	7.3
SKL6-11	6	6	703	33.5	70	8.2
SKL9-5	9	6	1029	22.3	105	8.2
SKL9-7	9	9	1029	31.2	105	9.4
SKL9-9	9	9	1029	40.1	105	10.6
SKL9-11	9	9	1029	49.0	105	11.8

Faucet Options:

- _ Single ball valve mounted to frame with 48" vinyl flexible spray hose assembly
 - _ 48" flexible spray hose assembly (vinyl or stainless) for use with dual or single fill faucet
 - _ Automatic water filling meter
- (Call for information regarding additional faucet options)*

Prison/Security Options:

- _ Fasteners (screws & nuts)
- _ Nut driver tool
- _ Draw-off nut driver tool
- _ Screw driver tool
- _ Lockable control cover
- _ Draw-off protection

Other Options:

- _ Electric timer with buzzer
- _ Knockdown capability for 26" x 66" opening (*shipped assembled*)

Accessories:

- _ Perforated cooking/steaming basket (11" x 20½" x 5")
- _ Perforated or solid 12 x 20 food pans, 2½, 4 or 6 inch deep
- _ Draw-off drain spout
- _ Draw-off strainer
- _ Draw-off drain hose
- _ #10 Can holder for draw-off
- _ Flat bottom scoop
- _ Fry scoop
- _ Skittle care kit

Select draw-off valve: 1.5" 2" 3"

With: compression ball type fitting

See price list for other draw-off options.

Select Voltage: 208V 240V 380V 415V 440V 480V

Select Phase: 1φ 3φ

Revision 512



LEGION Legion Industries, Inc.
(706) 554-4411 Fax: (706) 554-2035

P. O. Office Box 728 Waynesboro, GA 30830 (800) 887-1988
www.legionindustries.com sales@legionindustries.com

Skittle® Model SKL

Electric, Low Lid Profile
Insulated for Safety™
10° Tilting, Leg Mounted
Made in USA

Insulated Multi- Functional Cookers

DRAWING REPRESENTS MODEL SKL6-9 WITH STANDARD 1 1/2 DRAW-OFF

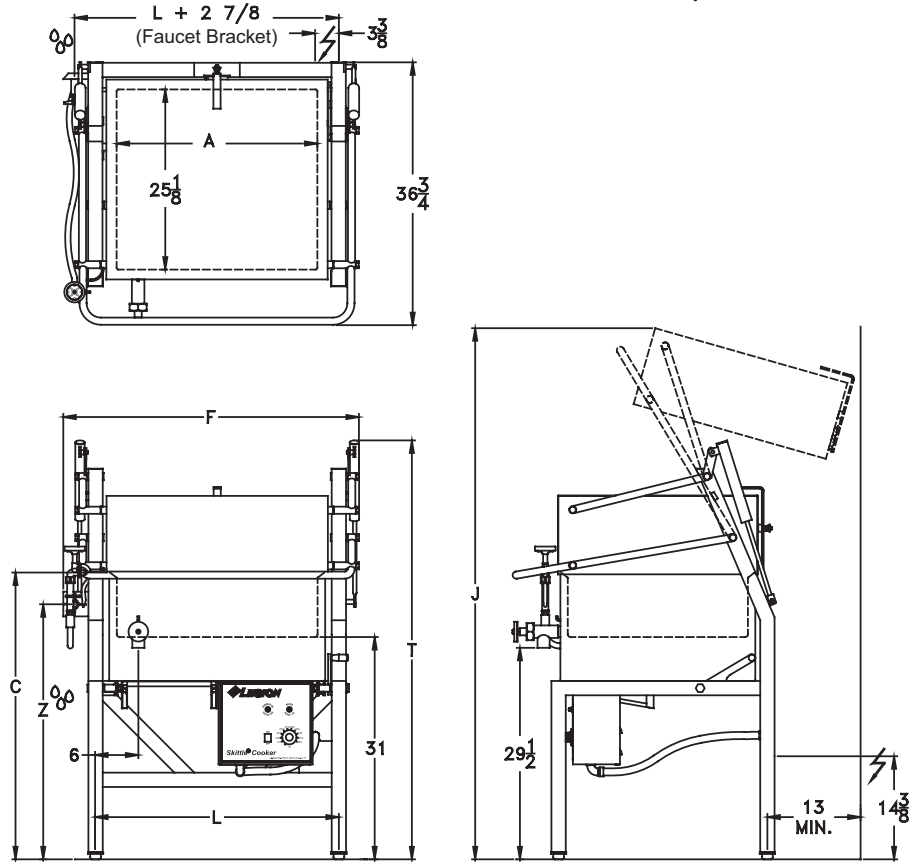

SKITTLE® DIMENSIONS

Model*	A	F	L	Model*	A	F	L	Model*	A	F	L	Depth	C	J	T	Z
SKL3-5	14.0	27.3	20.0	SKL6-5	28.0	41.3	34.0	SKL9-5	41.0	54.3	47.0	5	36.0	70.3	53.3	31.5
SKL3-7	14.0	27.3	20.0	SKL6-7	28.0	41.3	34.0	SKL9-7	41.0	54.3	47.0	7	38.0	72.3	55.3	33.5
SKL3-9	14.0	27.3	20.0	SKL6-9	28.0	41.3	34.0	SKL9-9	41.0	54.3	47.0	9	40.0	74.3	57.3	35.5
N/A			SKL6-11**	28.0	41.3	34.0	SKL9-11**	41.0	54.3	47.0	11	42.0	76.3	59.3	37.5	

*Dimensions on these drawings are applicable only when using a 1.5" diameter draw-off valve. If a 2" or 3" diameter draw-off valve is required, contact Legion for applicable dimensions.

**Note: Vertical dimensions of 11" deep pan may be reduced by 2" to match 9" deep pan

SKITTLE® ELECTRICAL SPECIFICATIONS (Amperes per Leg)

Model*	kW	208 Volt		240 Volt		380 Volt	415 Volt	440 Volt	480 Volt
		1 Phase	3 Phase-Δ	1 Phase	3 Phase-Δ	3 Phase-Y	3 Phase-Y	3 Phase-Y	3 Phase-Y
SKL3-()	5.9	25.6	14.8	24.6	14.2	9.0	8.2	7.8	7.1
SKL6-()	11.8	51.3	29.6	49.3	28.4	18.0	16.4	15.5	14.2
SKL9-()	17.7	76.9	44.4	73.9	42.7	27.0	24.6	23.3	21.3

U.S. Patent Nos. 5,553,531, 5,964,145, & Des. 371,715

512



LEGION Legion Industries, Inc. P.O. Office Box 728 Waynesboro, GA 30830 (800) 887-1988
(706) 554-4411 Fax: (706) 554-2035 www.legionindustries.com sales@legionindustries.com