

# 2 Trolley Roll-In Blast Chiller/Shock Freezer

- Exceeds food safety standards chilling from 194°F to 37°F in 90 min & freezing from 94°F to 0°F in 270 min
- Technology proven to preserve nutrients, aid in reducing food waste, and minimize preparation times
- Roll-In unit fits 2 full-sized speed racks or combi carts (not included)
- Touch screen control allows for preset chill and freeze cycles and custom recipe creation



UCBF659-SS12A

(Cabinet)



(Remote condenser unit included)

Model	Description	Voltage/Hz/Phase/Amps	Shipping Weight
UCBF659-SS12A	2 Trolley Roll-In Blast Chiller/Shock Freezer, (Cabinet)	220 / 60 / 1 / 4	2,491 lbs
	Remote Condenser	220 / 60 / 3 / 47.1	

### Specifications

UCBF659-SS12A cabinet dimensions: 88 7/8" H x 59 1/4" W x 75 29/32" D

UCBF659-SS12A remote condenser unit dimensions: 28" H x 56 1/8" W x 40 1/2" D

Additional assembly required: ships in 3 pieces

AISI 304 Stainless steel interior and exterior, ETL sanitation certified

Autodefroster

Blast chilling yield (194°F to 37°F in 90 min): 617 lb / Shock freezing yield (194°F to 0°F in 270 min): 507 lb

Environmentally friendly R452A refrigerant: 282 oz (8.0 kg)

Interior rounded corners, removable door gasket, and evaporator compartment for easy cleaning

Multi-core probe with 4 reading points

NSF/ANSI Standard 7 compliant

Operating temperature range: -40°F to 50°F

Remote condensing unit included (assembly required). 33' run distance

Self-closing door with 105° stop.

Self-lubricating, sealed cast iron evaporator fan motor with high volume air flow design

7" digital touch screen control with HACCP data tracker and alarms. Cycles include soft chill, hard chill, soft freeze, hard freeze, holding, and end of cycle hold mode.

11.2" ramp included



# Product Specifications • 2 Trolley Roll-In Blast Chiller/ Shock Freezer

### Top

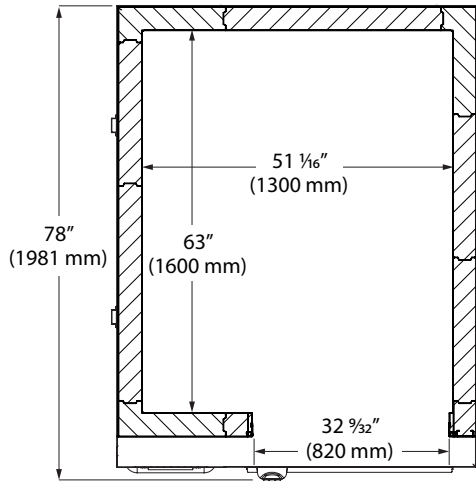

### Remote Condensing Unit

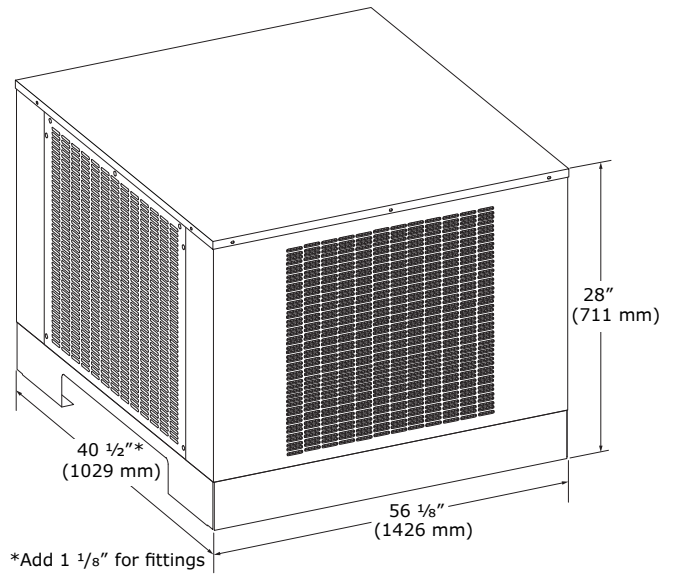

### Front

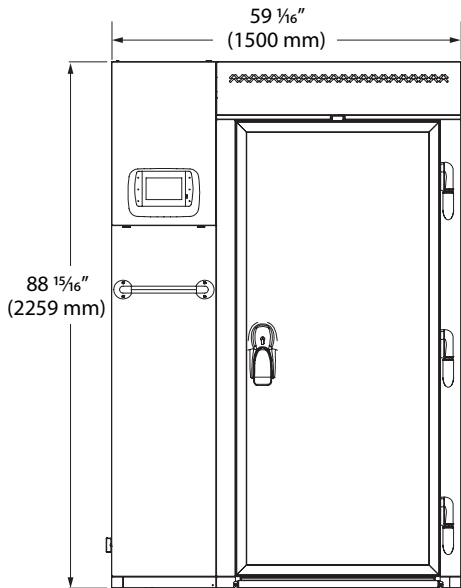

### Side

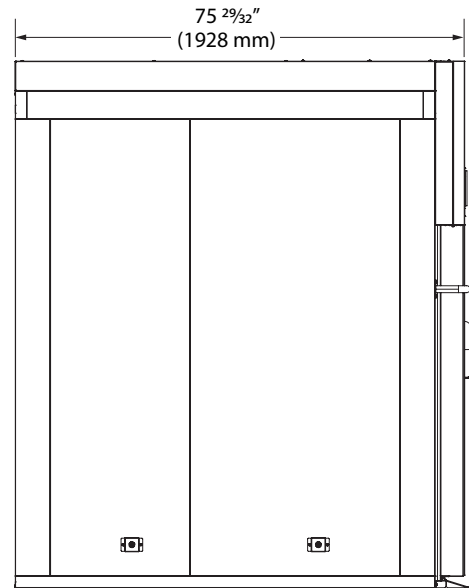

Note: Condensing unit requires clearance of 39 3/8" on all sides for proper ventilation.

Remote condenser unit: 72207.897 BTU/h chilling, 12059.091 BTU/h freezing / 7.5 HP RLA: 23.7 A | LRA: 107 A | MCA 34.725 A | MOP 58.425 A

## Commercial Warranty

3 Year (parts & labor) / 5 year sealed system (parts)  
See complete warranty for details

\*All tests completed using 2" thick food products



Intertek